

Ball Valve (VS), DN 2" [50], 2-way, Cv 108



2-year warranty



Picture may differ from product

Type overview

Type	DN
B249VS	2" [50]

Technical data

Functional data	Valve size [mm]	2" [50]
	Fluid	chilled or hot water, up to 60% glycol, steam
	Fluid Temp Range (water)	-22...280°F [-30...138°C]
	Body Pressure Rating	600 psig WOG psi
	Close-off pressure Δps	600 psi
	Flow characteristic	modified equal percentage
	Leakage rate	ANSI Class VI
	Pipe connection	Internal thread NPT (female)
	Max Differential Pressure (Steam)	35 psi
	Flow Pattern	2-way
	Controllable flow range	90° rotation
	Cv	108
	Maximum Inlet Pressure (Steam)	35 psi [241 kPa]
	Materials	Valve body
Housing seal		PTFE
Stem		316 stainless steel
Stem seal		RPTFE
Seat		RPTFE
Lock nut		stainless steel
Retainer		B584-C84400 bronze
Ball		316 stainless steel
Suitable actuators	Non Fail-Safe	GMB(X) PRB(X) SY1
	Spring	AF
	Electronic fail-safe	GMB(X) PKRB(X)

Safety notes

- **WARNING:** This product can expose you to lead which is known to the State of California to cause cancer and reproductive harm. For more information go to www.p65warnings.ca.gov

Product features

Application This valve is typically used in air handling units on heating or cooling coils, and fan coil unit heating or cooling coils. Some other common applications include Unit Ventilators, VAV Box re-heat coils and bypass loops. This valve is suitable for use in a hydronic system with variable flow.

This valve is designed with MFT functionality which facilitates the use of various control input.

Up to 35 psi steam

1/2" - 2" 600 PSIG WOG, Cold Non-Shock

Federal Specification: WW-V-35C, Type II

Composition: BZ

Style: 3

Flow/Mounting details

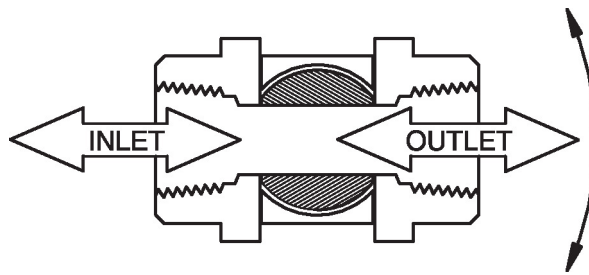

Dimensions

Type	DN	Weight
B249VS	2" [50]	6.2 lb [2.8 kg]

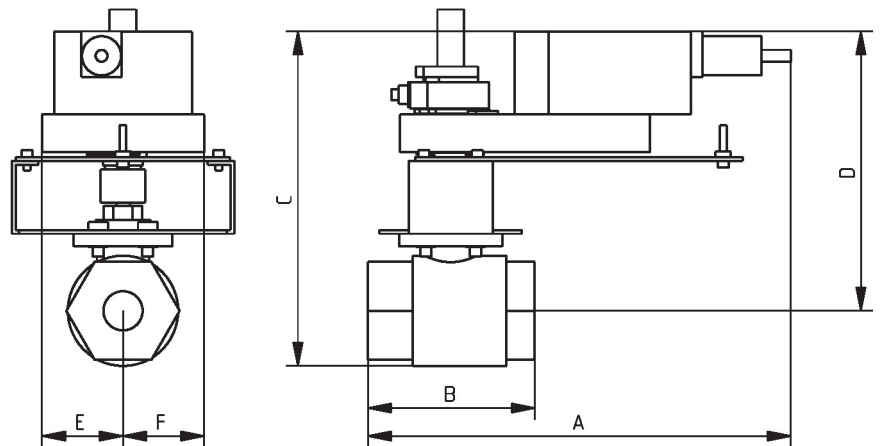

B249VS+GK..X1

A	B	C	D	E	F
11.9" [302]	4.7" [119]	10.0" [254]	7.9" [200]	2.3" [58]	2.3" [58]

Dimensions

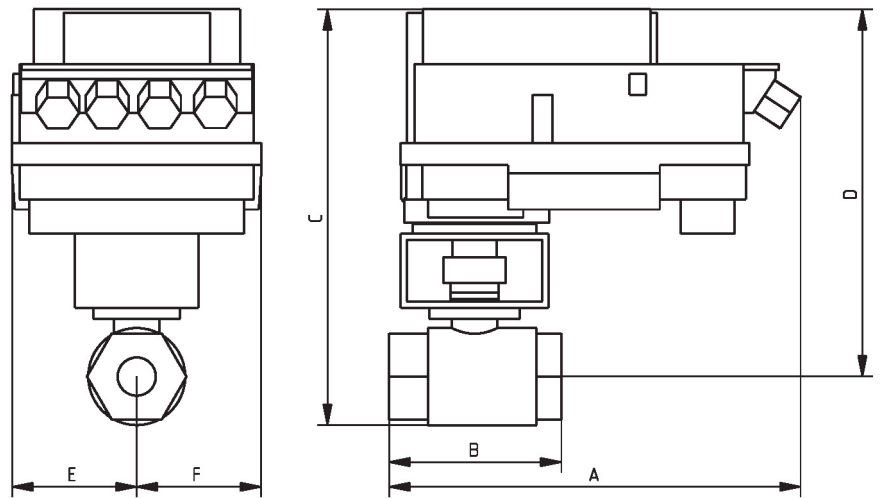

B249VSS+PKR..

On/Off, Floating point, Non fail-safe, 24...240 V

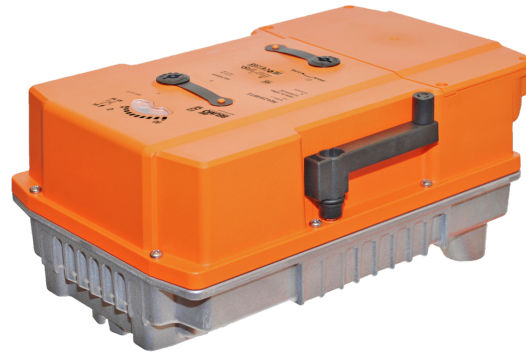

5-year warranty

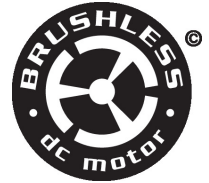
Technical data

Electrical data	Nominal voltage	AC 24...240 V / DC 24...125 V
	Nominal voltage frequency	50/60 Hz
	Nominal voltage range	AC 19.2...264 V / DC 19.2...137.5 V
	Power consumption in operation	23 W
	Power consumption in rest position	7.5 W
	Transformer sizing	with 24 V 23 VA / with 240 V 55 VA
	Auxiliary switch	2x SPDT, 1 mA...3 A (0.5 A inductive), DC 5 V...AC 250 V (II, reinforced insulation), 1x 10° / 1x 0...90° (default setting 85°)
	Switching capacity auxiliary switch	1 mA...3 A (0.5 A inductive), DC 5 V...AC 250 V (II, reinforced insulation)
	Electrical Connection	Terminal blocks, (PE) Ground-Screw
	Overload Protection	electronic throughout 0...90° rotation
Functional data	Direction of motion motor	reversible with app
	Manual override	7 mm hex crank, supplied
	Angle of rotation	90°
	Running Time (Motor)	35 s / 90°
	Noise level, motor	68 dB(A)
	Position indication	integral pointer
Safety data	Power source UL	Class 2 Supply
	Degree of protection IEC/EN	IP66/67
	Degree of protection NEMA/UL	NEMA 4X
	Housing	UL Enclosure Type 4X
	Agency Listing	cULus acc. to UL60730-1A/-2-14, CAN/CSA E60730-1:02, CE acc. to 2014/30/EU and 2014/35/EU
	Quality Standard	ISO 9001
	Ambient humidity	Max. 100% RH
	Ambient temperature	-22...122°F [-30...50°C]
	Servicing	maintenance-free
Weight	Weight	6.8 lb [3.1 kg]
Materials	Housing material	Die cast aluminium and plastic casing

Safety notes



- For maintenance work, the correct valve position must be set via the control signal. Additionally, the actuator must be disconnected from the power source. The hand crank and manual override shall not be used as a safety measure to maintain the valve position.

Product features

- Application** PR Series valve actuators are designed with an integrated linkage and visual position indicators. For outdoor applications, the installed valve must be mounted with the actuator at or above horizontal. For indoor applications the actuator can be in any location including directly under the valve.
- Operation** The PR series actuator provides 90° of rotation and a visual indicator shows the position of the valve. The PR Series actuator uses a low power consumption brushless DC motor and is electronically protected against overload. A universal power supply is furnished to connect supply voltage in the range of AC 24...240 V and DC 24...125 V. Included is a smart heater with thermostat to eliminate condensation. Two auxiliary switches are provided; one set at 10° open and the other is field adjustable. Running time is field adjustable from 30...120 seconds by using the Near Field Communication (NFC) app and a smart phone.
- †Use 60°C/75°C copper wire size range 12...28 AWG, stranded or solid. Use flexible metal conduit. Push the listed conduit fitting device over the actuator’s cable to butt against the enclosure. Screw in conduit connector. Jacket the actuators input wiring with listed flexible conduit. Properly terminate the conduit in a suitable junction box. Rated impulse Voltage 4000 V. Type of action 1. Control pollution degree 3.

Accessories

Mechanical accessories	Description	Type
	Hand crank for PR, PKR, PM	ZG-HND PR

Electrical installation

- ◆ Meets cULus requirements without the need of an electrical ground connection.
- UP Universal Power Supply (UP) models can be supplied with AC 24...240 V, or DC 24...125 V.
- ⚡ Disconnect power.
- 1 Provide overload protection and disconnect as required.
- 4 Two built-in auxiliary switches (2x SPDT), for end position indication, interlock control, fan startup, etc.
- 46 Actuators may be controlled in parallel. Current draw and input impedance must be observed.
- ⚠ **Warning! Live electrical components!**
During installation, testing, servicing and troubleshooting of this product, it may be necessary to work with live electrical components. Have a qualified licensed electrician or other individual who has been properly trained in handling live electrical components perform these tasks. Failure to follow all electrical safety precautions when exposed to live electrical components could result in death or serious injury.

Electrical installation

Wiring diagrams

On/Off

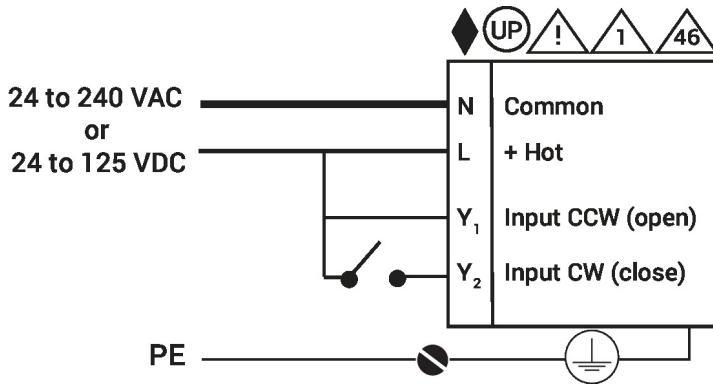

On/Off

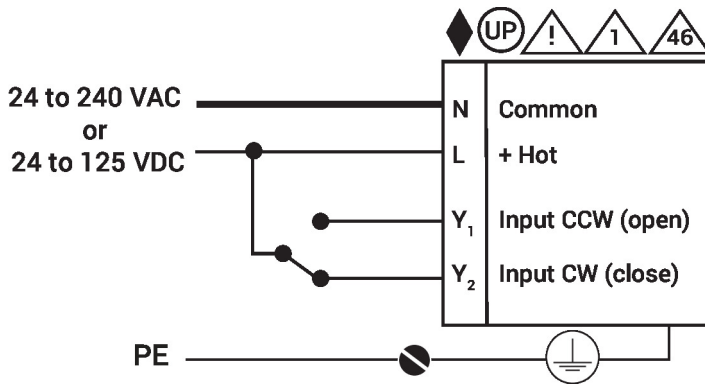

Floating Point

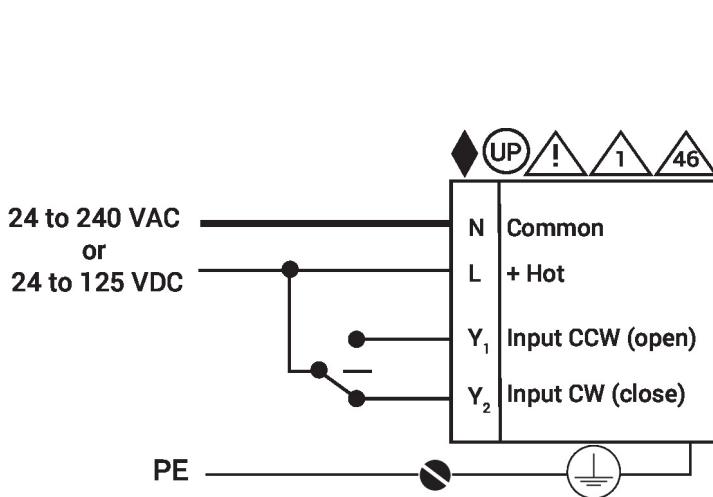

Auxiliary Switches

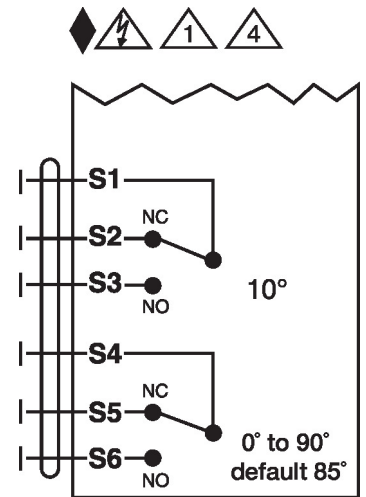

Dimensions

