

KPL, KWM

Service instructions



Original service instructions.

CONTENTS

	Page		Page
1. Symbols used in this document	2	15. Assembling KPL 900-1800, KWM 800-1600	36
2. Safety	3	15.1 Mounting the bearings and the lower bearing bracket	36
3. Handling and storage	3	15.2 Mounting the upper bearing bracket	37
3.1 Handling the pump	3	15.3 Mounting the shaft into the stator	37
3.2 Storing the pump	4	15.4 Mounting the discharge casing	37
4. Identification	4	15.5 Mounting the shaft seal	38
4.1 Nameplate	4	15.6 Mounting the propeller/impeller	38
5. Type key	5	15.7 Mounting the suction casing and the wear ring	39
6. Service tools	6	15.8 Mounting the sensors	40
6.1 Standard tools	6	15.9 Mounting the motor top cover	40
6.2 Special tools	7	15.10 Mounting the cable entry	40
6.3 Lifting tools	7	16. Starting-up the pump	41
7. Tightening torques and lubricants	8	16.1 General startup procedure	41
8. Electrical connection	8	16.2 Direction of rotation	41
8.1 Sensor fault finding	9	17. Fault finding	42
8.2 Terminal connections	10	18. Power-lock®	43
8.3 Symbols used in the wiring diagrams	11	19. Wiring diagrams	44
8.4 Wiring diagrams	12	20. Drawings	48
9. Pump protection	14	21. List of materials	58
10. Service	15	22. Exploded views	61
10.1 General information	15	23. Resistance table for the Pt100 sensor	65
10.2 Overhaul	15		
10.3 Inspection	15		
10.4 Propeller/impeller clearance	16		
10.5 Oil check and oil change	16		
11. Power-lock®	18		
11.1 Removing Power-lock®	18		
11.2 Mounting Power-lock®	18		
12. Dismantling KPL 500-800, KWM 600-700	19		
12.1 Removing the cables and the motor top cover	19		
12.2 Removing the power cable/sensor cable	20		
12.3 Removing the cable entries	20		
12.4 Removing the motor top cover	20		
12.5 Removing the suction casing	21		
12.6 Removing the wear ring	21		
12.7 Removing the propeller/impeller	22		
12.8 Removing the shaft seal	22		
12.9 Removing the discharge casing	23		
12.10 Removing the rotor with bearings	23		
12.11 Removing the lower bearings	24		
12.12 Removing the upper bearing and bearing bracket	24		
13. Assembling KPL 500-800, KWM 600-700	25		
13.1 Mounting the upper bearing bracket	25		
13.2 Mounting the bearings and the lower bearing bracket	25		
13.3 Mounting the discharge casing	25		
13.4 Mounting the shaft seal	26		
13.5 Mounting the propeller/impeller	27		
13.6 Mounting the suction casing and the wear ring	28		
13.7 Mounting the sensors	28		
13.8 Mounting the motor top cover	29		
13.9 Mounting the cable entry	30		
14. Dismantling KPL 900-1800, KWM 800-1600	31		
14.1 Removing the cables and the motor top cover	31		
14.2 Removing the power cable/sensor cable	32		
14.3 Removing the cable entry	32		
14.4 Removing the motor top cover	32		
14.5 Removing the suction casing	33		
14.6 Removing the wear ring	33		
14.7 Removing the propeller/impeller	33		
14.8 Removing the shaft seal	34		
14.9 Removing the discharge casing	34		
14.10 Removing the rotor with bearings	35		
14.11 Removing the lower bearings	35		
14.12 Removing the upper bearing and the bearing bracket	36		

1. Symbols used in this document

**Warning**

If these safety instructions are not observed, it may result in personal injury.

**Warning**

During electrical installation, make sure that the power supply cannot be accidentally switched on.

**Warning**

These instructions must be observed for explosion-proof versions. We recommend that you also follow these instructions for standard versions.

**Caution**

If these safety instructions are not observed, it may result in malfunction or damage to the equipment.

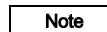
**Note**

Notes or instructions that make the job easier and ensure safe operation.

2. Safety



Warning
Pump installation in pits must be carried out by specially trained persons.



Warning
It must be possible to lock the mains switch in position 0. Type and requirements as specified in EN 60204-1, 5.3.2.



Warning
Observe local regulations setting limits for manual lifting or handling.



Warning
For safety reasons, all work in pits must be supervised by a person outside the pump pit.



Warning
Pits for submersible wastewater pumps contain wastewater with toxic and/or disease-causing substances. Therefore, all persons involved must wear appropriate personal protective equipment and clothing, and all work on and near the pump must be carried out under strict observance of the hygiene regulations in force.

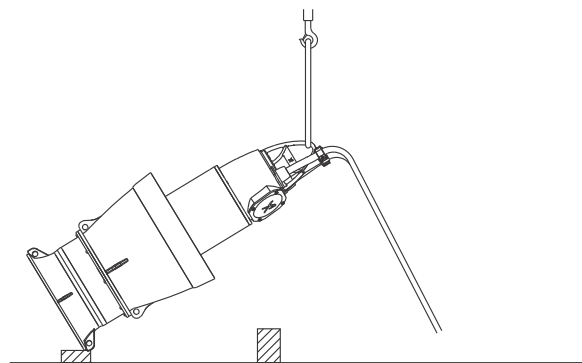

Fig. 2 Single-wire lift

TM05 9207 3313

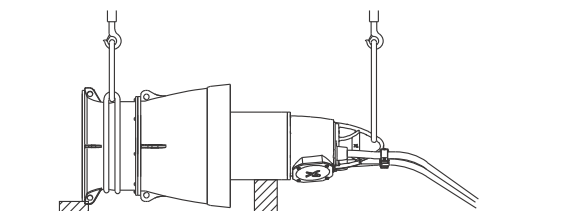

Fig. 3 Two-wire lift

TM05 9208 3313

3. Handling and storage

3.1 Handling the pump

It is very important to use the right lifting equipment. The weight of the pump is stated on the pump nameplate. All lifting equipment must be rated for the purpose and checked for damage before any attempts are made to lift the pump. The lifting equipment rating must under no circumstances be exceeded.



Warning
Always lift the pump by the lifting brackets or by means of a fork-lift truck, never by means of the cables.



Warning
Never lift the pump by the power cable. It may result in electric short circuit and risk of electric shock when the pump is connected to the mains. The cable and cable entry may be damaged, leading to loss of waterproofness and consequent severe damage to the motor.

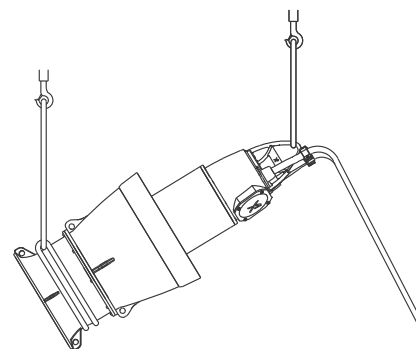

Fig. 4 Two-wire lift

TM05 9208 3313

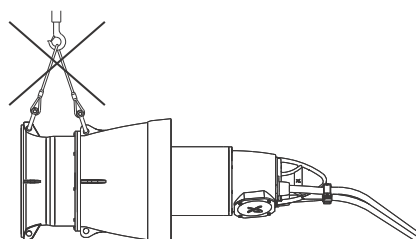

Fig. 5 Do not lift the pump like this

TM05 9209 3313

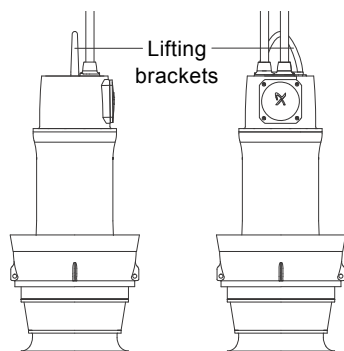

Fig. 1 Lifting brackets

TM05 5621 3912

The pump may lose its stability during transportation, assembly or dismantling if tilted more than 10 ° in any direction from its normal position.

Caution Do not lift the pump by the hydraulic parts.



Warning
Make sure that the lifting eye bolts are tightened before attempting to lift the pump. Carelessness during lifting or transportation may cause injury to personnel or damage to the pump.

3.2 Storing the pump

Do not remove the protection from the free end of the power cable or sensor cable until the electrical connection is to be made.

Caution

Whether protected or not, the free cable end must never be exposed to moisture or water.

Non-compliance may involve the risk of damage to the motor.

During long periods of storage, the pump must be protected against moisture and heat.

The pump is frost-proof as long as it is operating or immersed in the liquid.

If the pit has been pumped dry, and the pump has been exposed to the atmosphere, let the pump be immersed in the liquid for a short period before starting.

This will eliminate the possibility of a frozen propeller/impeller. Never use an open flame to thaw out the pump.

If the pump is stored dry, rotate the propeller/impeller by hand at least every two months to prevent the seals from seizing up.

If the pump is submerged, operate it for 30 seconds every month.

Note

If the pump cannot be turned by hand, contact an authorised service workshop.

During storage, pay special attention to the condition of the seals and the cable entry. Clean the pump regularly and spray it with corrosion-inhibiting oil. Always store the pump under cover in a protected area not exposed to direct sunlight.

Storage temperature

Normal	-25 °C - +55 °C
For short periods not exceeding 24 hours	+70 °C

4. Identification

4.1 Nameplate

The nameplate is fixed to the side of the stator housing near the cable entry to the motor.

Attach the additional nameplate supplied with the pump to the cable end in the control cabinet.

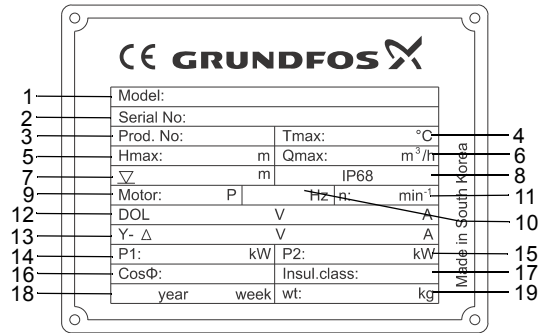

TM05 7247 1613

Pos.	Description
1	Type designation
2	Serial number
3	Product number
4	Maximum ambient temperature
5	Maximum head
6	Maximum flow rate
7	Maximum installation depth
8	Enclosure class according to IEC 60529
9	Number of poles
10	Frequency
11	Rated speed
12	Voltage/current, delta connection
13	Voltage/current, star-delta connection
14	Input power
15	Shaft power
16	Power factor
17	Insulation class
18	Production code, year/week
19	Pump weight

5. Type key

All KPL and KWM pumps are identified by the type designation stated in the order confirmation and in other documentation supplied with the pump.

Code	Example	KPL	.1800	.600	.16	.T	.50	.17	.L	.40	.Z
	Pump type										
KPL	Submersible axial-flow pump										
KWM	Submersible mixed-flow pump										
	Column pipe diameter										
500	DN 500										
600	DN 600										
700	DN 700										
800	DN 800										
900	DN 900										
1000	DN 1000										
1200	DN 1200										
1400	DN 1400										
1500	DN 1500										
1600	DN 1600										
1800	DN 1800										
	Motor power [kW]										
	Number of poles										
4	4-pole										
6	6-pole										
8	8-pole										
10	10-pole										
12	12-pole										
14	14-pole										
16	16-pole										
18	18-pole										
	Number of phases										
T	Three-phase motor										
	Frequency										
50	50 Hz										
60	60 Hz										
	Hydraulic properties										
	KPL (propeller pitch angle):										
9	9 degrees										
11	11 degrees										
13	13 degrees										
15	15 degrees										
17	17 degrees										
19	19 degrees										
21	21 degrees										
	KWM (actual impeller diameter): [mm]										
	Pump range/pressure										
H	KWM - High head										
M	KWM - Medium head										
L	KPL - Low head										
E	KPL - Extra low head										
	Voltage [V]										
23	230										
38	380										
40	400										
41	415										
46	460										
57	575										
66	660										
69	690										
3H	3300										
4H	4160										
6H	6000										
7H	6600										
	Product variant										
Z	Custom-built variant										

6. Service tools

Service of a KPL, KWM pump requires, besides standard and special tools, sufficient lifting equipment and, if possible, some pallets to put for instance the suction casing, discharge casing, propeller or motor on, when they have been removed from the pump.

6.1 Standard tools

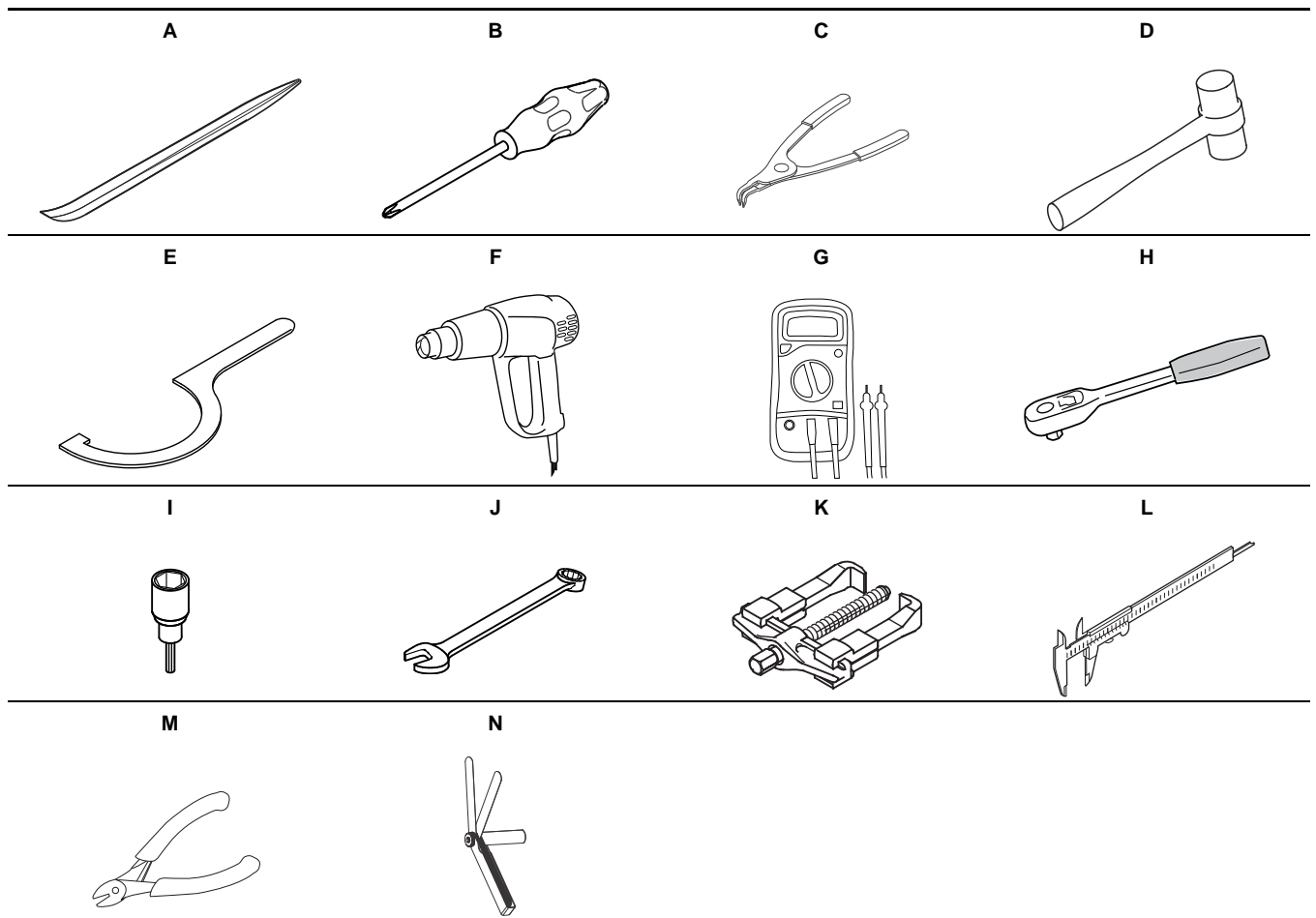

Standard tools

Pos.	Range	Designation	Description	Part number
A	All	Pinch bar	-	SV5201
B	All	Screwdriver	Straight slot	-
C	All	Circlip pliers	-	SV2014
D	All	Plastic hammer	-	SV0349
E		Hook spanner (FAG)	KM18-20	-
			KM21-23	-
			KM24-27	-
			KM28-30	-
			KM31-34	-
		KM36-40	-	
F	All	Heat gun	-	-
G	All	Multimeter	-	-
H	All	Ratchet handle 1/2"	-	96777072
			4 mm	SV0414
I	All	Hexagon head driver	M6 - 5 mm	SV0296
			M8 - 6 mm	SV0297
			M10 - 8 mm	SV0298
			M12 - 10 mm	SV0299
			M16 - 12 mm - 1/2"	SV0394

Pos.	Range	Designation	Description	Part number
J	All	Ring/open-end spanner	8 mm	SV0273
			10 mm	SV0083
			12 mm	SV0274
			16 mm	SV0185
			20 mm	-
			24 mm	SV0122
			27 mm	SV0084
			30 mm	SV0073
K	All	Puller for bearing	-	SV0335
L	All	Sliding gauge	0-150 mm	SV0307
M	All	Side cutter	-	-
N	All	Feeler gauge	-	-

6.2 Special tools

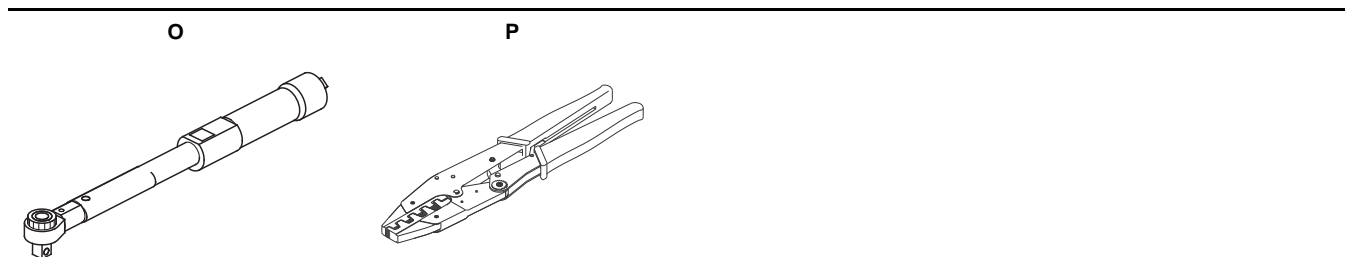

Special tools

Pos.	Range	Designation	Description	Part number
O	All	Torque wrench	-	-
P	All	Crimping tool	0.5 - 6.0 mm ²	98803499

6.3 Lifting tools

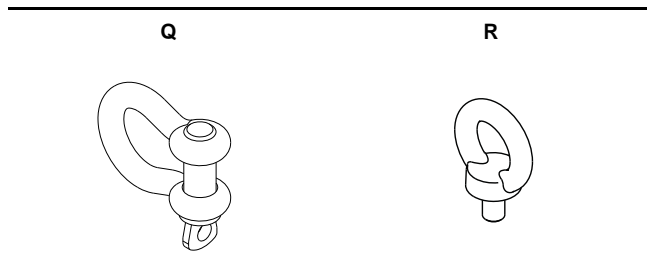

Lifting tools

Pos.	Designation	Description	Part number
Q	Shackle	All	-
R	Eyebolt	All	-

7. Tightening torques and lubricants

The following instructions will not contain information regarding torques for bolts and nuts. When assembling the pump, identify the size and class of the bolts and nuts used in the pump and then use the torque table below to determine the right torque.

Stainless steel	
Property class 70-80	
Size of thread	[Nm]
M4	2.7
M5	5.4
M6	9.0
M8	22.0
M10	44.0
M12	76.0
M16	187.0
M20	364.0
M24	629.0
M30	1240.0

Fig. 6 Torque table

Note The table is for lubricated hexagon head screws or hexagon socket head cap screws.

Lubricants

If nothing else is specified, all O-rings are to be lubricated with Rocol Sapphire Aqua-Sil.

Product	Product number
Rocol Sapphire Aqua-Sil (1 kg)	RM2924
Castrol Optimol Paste White T (0.5 kg)	V6001176

Power-lock®

The table below gives information about the Power-lock® keyless locking device.

Description	Thread	Screws	Torque [Nm]
M06.DR200-30x55	M6	12	17
M06.DR200-35x60	M6	12	17
M06.DR200-40x65	M6	14	17
M08.DR200-50x80	M8	12	37
M08.DR200-60x90	M8	14	37
M08.DR400-50x80	M8	9	41
M08.DR400-60x90	M8	10	41
M10.DR400-70x110	M10	11	83
M10.DR400-75x115	M10	11	83
M10.DR400-80x120	M10	12	83
M10.DR400-90x130	M10	13	83
M12.DR400-100x145	M12	12	145
M12.DR400-110x155	M12	13	145
M12.DR400-120x165	M12	15	145
M14.DR400-130x180	M14	13	230
M14.DR400-140x190	M14	15	230
M14.DR400-150x200	M14	16	230
M14.DR400-160x210	M14	16	230

Fig. 7 Power-lock® torque table

8. Electrical connection

All electrical work must be carried out by an authorised electrician.

Warning

Make sure that the earth conductor is completely connected after testing.
All control panels must be earthed. If they are not properly earthed, this may cause lethal accidents.

Switch off the power supply and control circuit and lock the main switch in position "0".

Lead colours

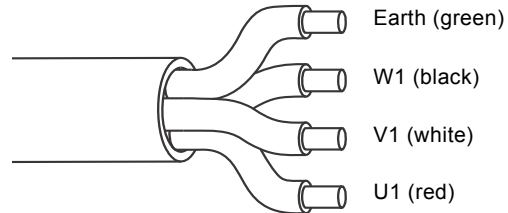

Fig. 8 Lead colours, 3-phase power cable.

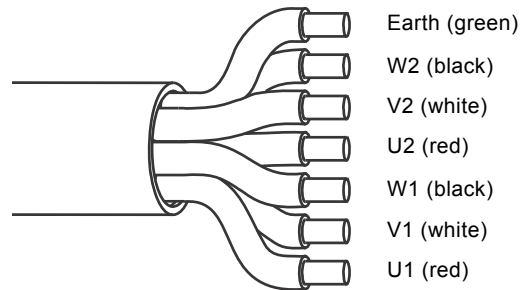

Fig. 9 Lead colours, 6-phase power cable

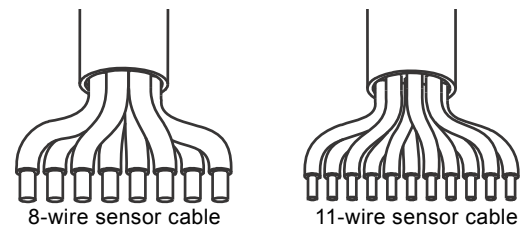



Fig. 10 Sensor cables

The sensor wires are numbered from 1 to 11. The use of 8-core and 11-core sensor cables will depend on the sensors used. See figs 20-23.

Warning

The earth conductor is green and marked "PE".

Insulation measurement

After installing the pump, make sure that the power cable insulation is intact. Make an insulation test between each of the phases (U, V, W) and (U, V, W) and PE. See fig. 11.

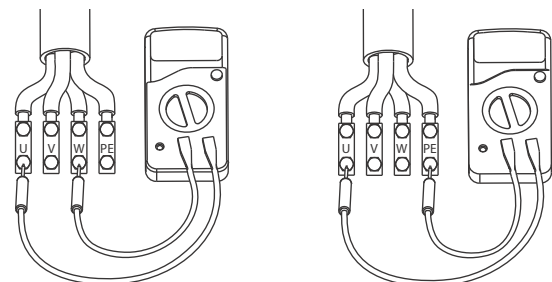

Fig. 11 Measuring insulation of power cables

8.1 Sensor fault finding

When the pump is connected to an IO 113 with or without an SM 113 module, it is possible to identify faults by means of its display. See instruction and operating instructions for IO 113.

If you require a more detailed fault finding, such as size of mA in WIO, use PC Tool.

By means of a multimeter (pos. G) you can make fault finding of the following sensors and switches:

- water-in-oil sensor
- oil level sensor
- thermal switch in stator (PTC and Klixon)
- bearing temperature sensor
- moisture switches
- pump vibration sensor (PVS3).

For the location of the different sensors and switches, see section [9. Pump protection](#).

8.1.1 SM 113 placed outside the pump

Moisture switch:

1. Disconnect wires 2 and 3 from the IO 113 terminal.
2. Connect the multimeter to wires 2 and 3
3. If there is connection between wires 2 and 3 through the multimeter, both moisture switches are OK. If not, one of them has been activated and needs to be changed. Find the reason for this before starting up again.

Moisture switch fault finding table

Multimeter connection	Measure between these two wires on IO 113	
	2	3
One moisture switch is faulty	No connection	
Moisture switches are OK	Connection	

Thermal switch fault finding table

Multimeter connection	Measure between these two wires on IO 113	
	1	3
One thermal switch is faulty	No connection	
Thermal switches are OK	Connection	

Pt100 fault finding table

Multimeter connection	Measure between these two wires on SM 113*	
	5	4 or 6 or 7
Wires 5 and 4 - Lower bearing sensor	See section 23. Resistance table for the Pt100 sensor	
Wires 5 and 7 - Upper bearing sensor		
Wires 5 and 6 - Temperature sensor in stator		

* When fault finding Pt100 sensors, set the multimeter to measure resistance [Ω].

WIO fault finding table

Multimeter connection	Measure between these points:*	
	SM 113 terminal	Wire no.
	4	8
Measured value: 0 mA	Fault	
Measured value: 3.5 mA	Low oil level	
Measured value: 22 mA	Water content high	
Measured value: 4-20 mA	0-20 % water in oil	

PVS3 fault finding table

Multimeter connection	Measure between these points:*	
	SM 113 terminal	Wire no.
	1	10
Measured value: 0 mA	Fault	
Measured value: 4-20 mA	Sensor OK	

* When fault finding 4-20 mA sensors, change the test leads into the correct sockets of the multimeter so it can measure current. See user instructions for the multimeter.

8.1.2 SM 113 placed inside the pump

Fault finding analog sensors with a multimeter is only possible if you have access to the terminal box. Otherwise use the display of IO 113. Fault finding switches (ON/OFF) is still possible when the pump is submerged.

Moisture switch fault finding table

Multimeter connection	Measure between these two wires on IO 113	
	2	3
One moisture switch is faulty	No connection	
Moisture switches are OK	Connection	

Thermal switch fault finding table

Multimeter connection	Measure between these two wires on IO 113	
	1	3
One thermal switch is faulty	No connection	
Thermal switches are OK	Connection	

Pt100 fault finding table**

Multimeter connection	Measure between these two points on SM 113:*	
	SM 113 terminal	Wire no.
	5	12, 13, 14
Wires 5 and 12 - Lower bearing sensor	See section 23. Resistance table for the Pt100 sensor	
Wires 5 and 13 - Upper bearing sensor		
Wires 5 and 14 - Temperature sensor in stator		

* When fault finding Pt100 sensors, set the multimeter to measure resistance [Ω].

** Access to SM 113 in the terminal box is necessary.

WIO fault finding table**

Multimeter connection	Measure between these points:*	
	SM 113 terminal	Wire name
	4	WIO
Measured value: 0 mA	Fault	
Measured value: 3.5 mA	Low oil level	
Measured value: 22 mA	Water content high	
Measured value: 4-20 mA	0-20 % water in oil	

PVS3 fault finding table**

Multimeter connection	Measure between these points:*	
	SM 113 terminal	Wire name
	1	PSV
Measured value: 0 mA	Fault	
Measured value: 4-20 mA	Sensor OK	

* When fault finding 4-20 mA sensors, change the test leads into the correct sockets of the multimeter so it can measure current. See user instructions for the multimeter.

** Access to SM 113 in the terminal box is necessary.

8.2 Terminal connections

The KPL, KWM pumps can be connected to the power grid in three different ways:

- direct wire connections through wire joints
- low-voltage terminal board connection
- high-voltage terminal board connection.

8.2.1 Direct wire connection

This type of connection is only possible in KPL 500-600 pumps. See fig. 12.

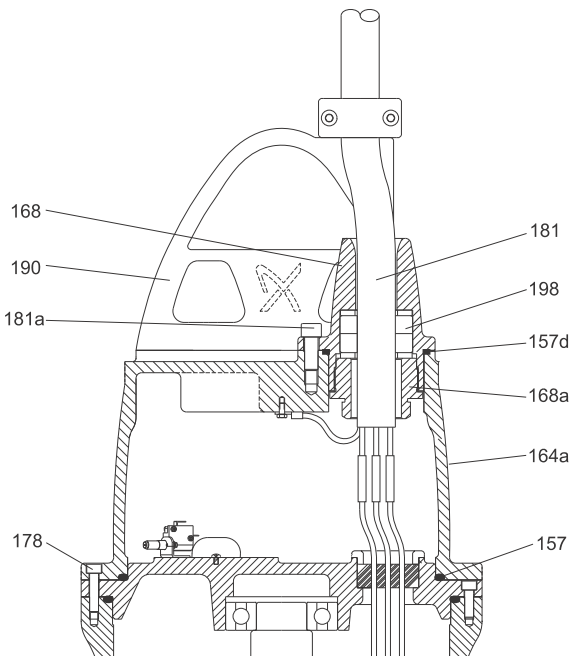

Fig. 12 Wire connection, KPL 500-600.

Figure 13 illustrates the correct way of joining the wires on a pump with direct wire connection.

In order to join the wires correctly, refer to section 8.4 [Wiring diagrams](#).

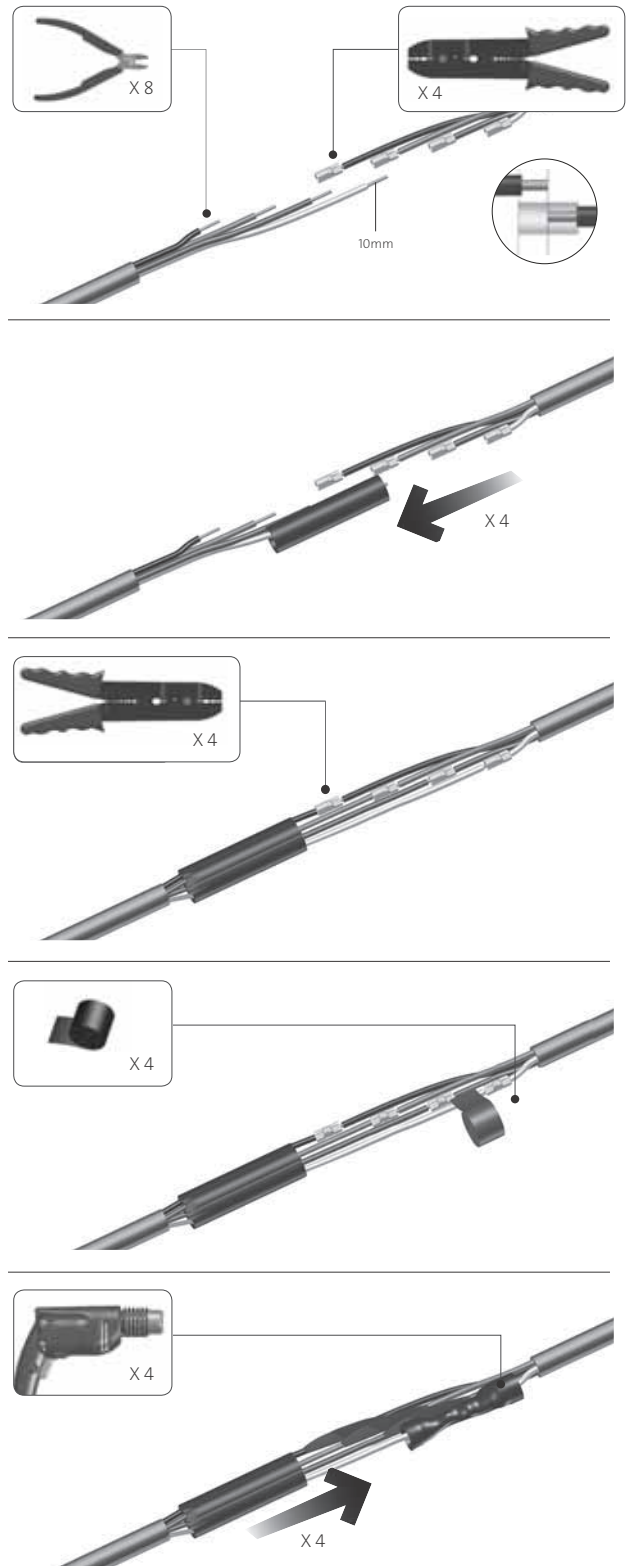

Fig. 13 How to join cables, KPL 500-600

TM06 2828 4714

TM06 2997 4814

8.2.2 Low-voltage connection

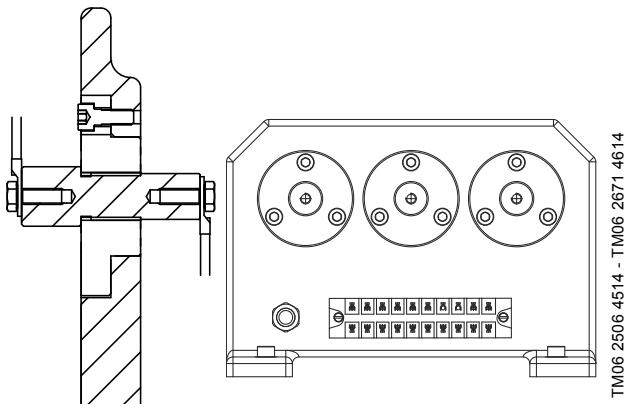

Fig. 14 Terminal board, low voltage

8.2.3 High-voltage connection

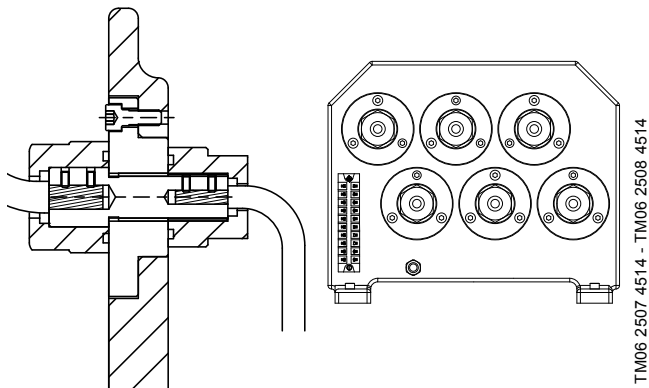

Fig. 15 Terminal board, high voltage

8.3 Symbols used in the wiring diagrams

Symbol	Description
	Thermal switch
	Moisture switch
	Pt100 sensor
	Earth conductor
	Water-in-oil sensor

8.4 Wiring diagrams

Power cables

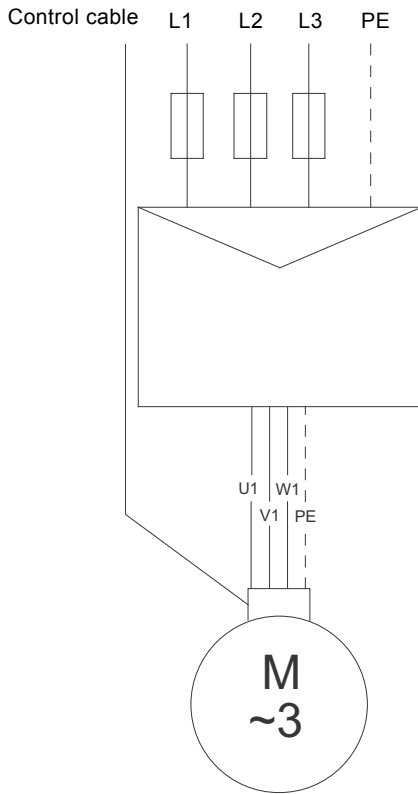

Fig. 16 Direct-online-starting (DOL), one power cable

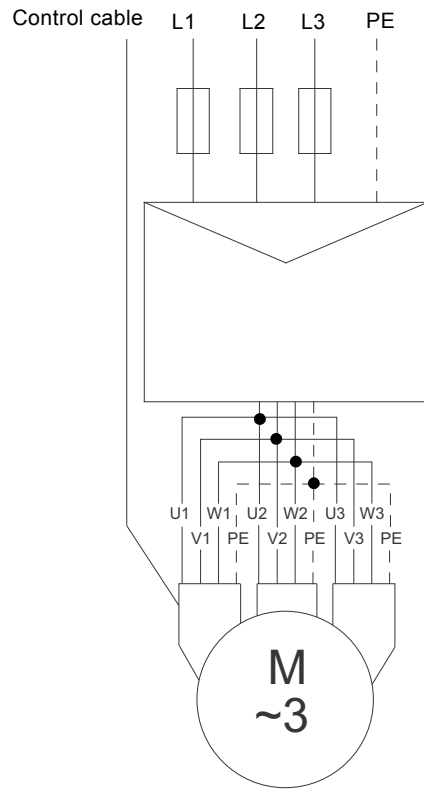

Fig. 18 Direct-online-starting (DOL), three power cables

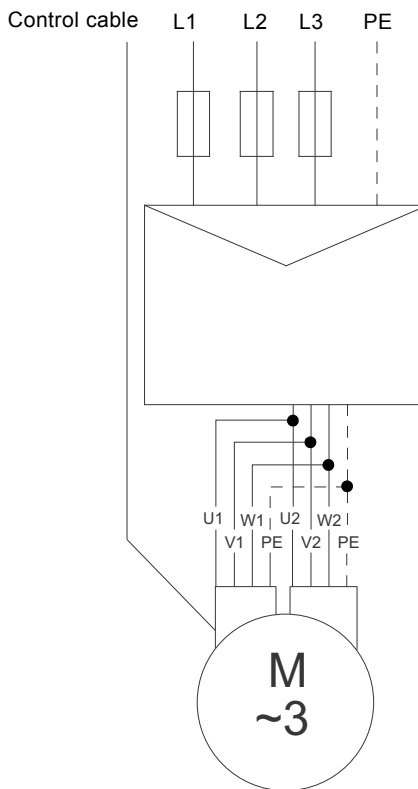

Fig. 17 Direct-online-starting (DOL), two power cables

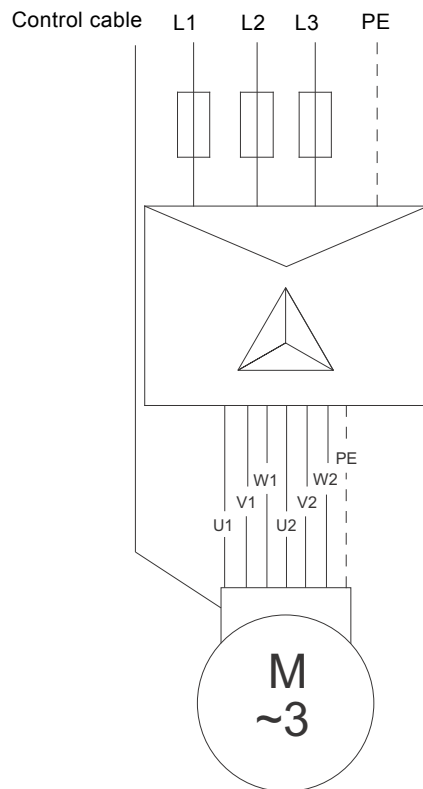

Fig. 19 Star-delta starting (Y/D), one power cable

TM05 6180 4512

TM05 6182 4512

TM05 6181 4512

TM05 6183 4512

9. Pump protection

KPL, KWM pumps are equipped with the following protective switches and sensors. In the FPV (Factory Product Variant) version, the sensors can be chosen individually.

Sensor	Type	Standard [Qty]	FPV [Qty]
Thermal switch, stator	Bi-metal	3	3
Temperature sensor, stator	Pt-100	1	3*
Terminal box moisture switch	Switch	1	1
Motor housing moisture switch	Switch	1	1
Temperature sensor, lower bearing	Pt-100	1	1
Temperature sensor, upper bearing	Pt-100	1	1
Water-in-oil sensor (WIO)	Analog		1
Vibration sensor (PVS3)	Analog		1

* Three Pt-100 sensors are installed in the pump from factory, but only one sensor is connected as standard. It is not possible to connect all three stator thermal switches, if bearing sensors are also connected.

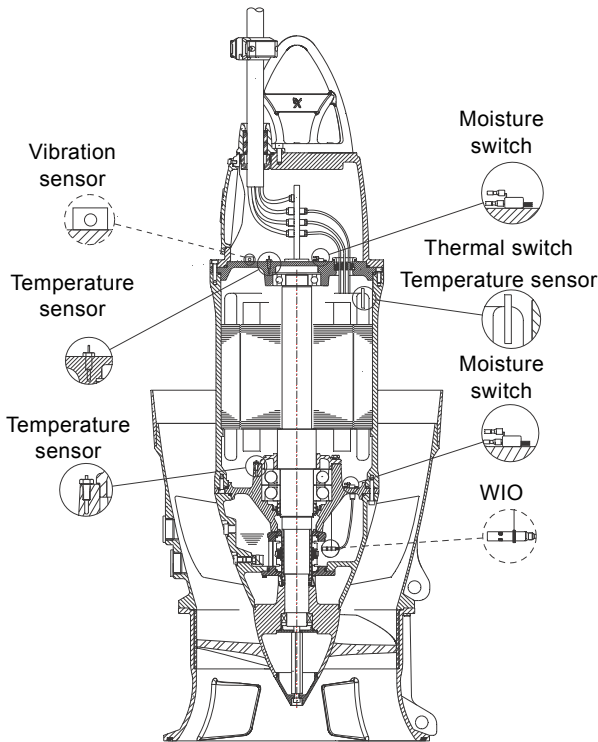

Fig. 24 Switches and sensors of KPL

TM05 9557 4013

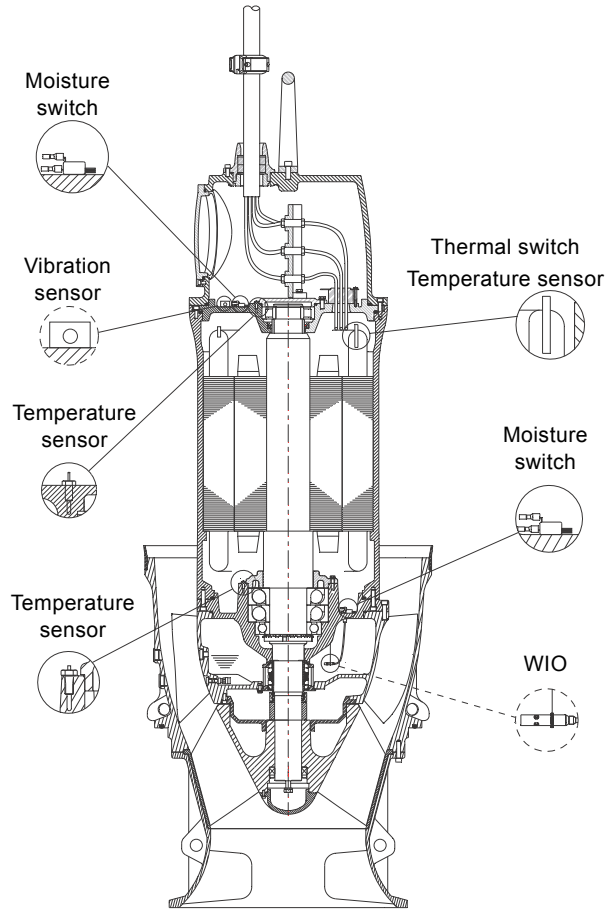

Fig. 25 Switches and sensors of KWM

TM05 9558 4013

10. Service

10.1 General information



Warning

Before starting work on the pump, make sure that the mains switch has been locked in position 0.

All rotating parts must have stopped moving.

Service must be carried out by specially trained persons. Before carrying out maintenance and service, make sure that the pump has been thoroughly flushed with clean water. Rinse the pump parts with water after dismantling.

Before assembly:

- Clean and check all parts.
- Replace defective parts with new parts.
- Order the necessary service kits.
- Always replace gaskets and O-rings when overhauling the pump.

During assembly:

- Lubricate and tighten screws and nuts to the correct torque as stated in section 7. *Tightening torques and lubricants.*

10.2 Overhaul

For pumps in long-term operation, we strongly recommend preventive maintenance at regular intervals.

For pumps installed in storm water pumping stations, service must be performed before and after the main working periods.

For pumps in specific applications or operating conditions, service must be performed more frequently.

Grundfos' sales companies may offer service contracts in accordance with a preventive maintenance schedule.

All service work must be carried out by specially trained persons.

10.3 Inspection

Pumps running in normal operating conditions must be inspected twice a year.

Check the following points during inspection:

Inspection	Remedy
Visible parts of pump and installation	Replace or fix worn and damaged parts. Make sure that all screws, bolts and nuts are tightened. Check the condition of lifting bracket/eye bolts, chains and wire rope.
Pump wear ring and propeller/impeller	Replace worn parts if they impair function. Check clearance between the propeller/impeller and the wear ring. It must not exceed 0.078 inches (20 mm).
Pumped liquid in oil chamber	Warning: If there has been a leakage through the seal, the oil chamber may be under pressure. Always unscrew the oil plug slowly in order to allow pressure to equalise, and preferably hold a rag over the inspection cover when unscrewing the screw to prevent spillage.
Liquid in the stator housing	If there is water in the stator housing, the cause may be as follows: <ul style="list-style-type: none"> – An O-ring is damaged. – The cable entry is leaking. If there is oil in the stator housing, the cause may be as follows: <ul style="list-style-type: none"> – The inner seal is damaged. – An O-ring is damaged.
Cable entry is leaking	<ul style="list-style-type: none"> – Make sure that the cable clamps are tight. – Make sure that the cable entry is tightened. – Cut off a piece of the cable so that the sealing sleeve will close around a new position on the cable. – Replace the sealing sleeve. – Check that the sealing sleeve and the washers correspond to the outside diameter of the cables.
Power cable	Replace the cable if the outer sheath is damaged. Make sure there is no slack in the cable suspension, and that the cable is fixed securely to the cable suspension and is unable to swing during operation.
Starter equipment	If faulty, contact an electrician.
Direction of rotation	If the propeller/impeller does not rotate clockwise, interchange two phases. Check the direction of rotation every time the pump is reconnected.
Pipes, valves and other peripheral equipment	Repair the faulty equipment.
Insulation resistance of the stator	Use an insulation resistance tester set to 1000 VDC. Check phase-to-phase and phase-to-earth resistance. The test result must be over 10 MΩ. Check the power cable insulation resistance according to the starting method of the pump.
Oil in oil chamber	Inspect pumps in intermittent operation once a year and pumps in constant operation every six months.

10.3.1 Oil level and oil condition

Check the oil level after one month of operation if the pump is new or the shaft seals have been replaced. The oil must be changed if it contains water.

Note *If the pump has a WIO sensor, you can ignore the above requirement.*

Warning
If there has been leakage through the seal, the oil chamber may be under pressure.
Always unscrew the oil plug slowly in order to allow pressure to equalise, and preferably hold a rag over the inspection cover when unscrewing the screw to prevent spillage.

Completely pump out the used oil, making sure that the removal tube goes all the way to the bottom of the oil chamber. For complete drainage, the pump must be tilted 60°. After refilling, tighten the oil plug to torque 80 Nm, 59 ft-lb.

Note *Dispose of used oil in accordance with local regulations.*

10.3.2 Cable entry

Make sure that the cable entry is waterproof and that the cables are not sharply bent or pinched.

10.3.3 Propeller/impeller clearance

Check the propeller/impeller clearance.

10.3.4 Pump parts

Check the suction and discharge casing for possible wear. Replace defective parts.

10.3.5 Bearings

Check the shaft for noisy or heavy operation by turning the shaft by hand. Replace defective ball bearings.

A general overhaul of the pump is usually required in case of defective ball bearings or poor motor function. This work must be carried out by an authorised service workshop.

We recommend inspection of the bearings after one week of operation when the pump is new or the shaft seals have been replaced.

Note *Regular inspection and preventive maintenance ensure a more reliable operation.*

10.4 Propeller/impeller clearance

When the clearance exceeds the values mentioned in the table below, we recommend a change of wear ring.

Column pipe diameter	Clearance	
	KPL [mm]	KWM [mm]
DN 500	0.40	-
DN 600	0.40	1.00
DN 650	0.40	-
DN 700	0.50	1.00
DN 800	0.50	1.00
DN 900	0.50	1.00
DN 1000	0.75	1.50
DN 1200	1.00	1.50
DN 1400	1.00	1.50
DN 1500	1.00	-
DN 1600	1.25	1.50
DN 1800	1.50	-

10.5 Oil check and oil change

The oil chamber is filled with oil acting as lubricant and coolant for the mechanical shaft seal.

Note *Check the oil regularly to avoid damage to and breakdown of the pump.*

Low oil level may indicate that the upper mechanical shaft seal is defective. Contact an authorised service workshop for further overhaul of the pump and repair, if required.

Warning
Lack of oil may cause overheating and damage of the mechanical shaft seals. The WIO sensor in the oil chamber will trip the alarm if the oil quality is poor or there is not enough oil in the oil chamber.

Note *Use oil with viscosity grade SAE 10 W 30 or SAE 10 W 40.*

Column pipe diameter	Oil quantity [litres]	
	KPL	KWM
DN 500	1.7	-
DN 600	2.2	8
DN 650	4.5	-
DN 700	6.0	9
DN 800	6.0	15
DN 900	12.0	17
DN 1000	13.0	20
DN 1200	24.0	24
DN 1400	34.0	30
DN 1500	36.0	-
DN 1600	37.0	-
DN 1800	-	-

Oil to be used: Castrol Hyspin AWS 32 or Shell Ondina X420

10.5.1 KPL 500-600

Proceed as follows:

1. Place the pump in vertical position and remove plug A.
2. Fit the drain pipe with valve. See fig. 27
3. Then turn the pump in horizontal position so that drain pipe is pointing downwards.

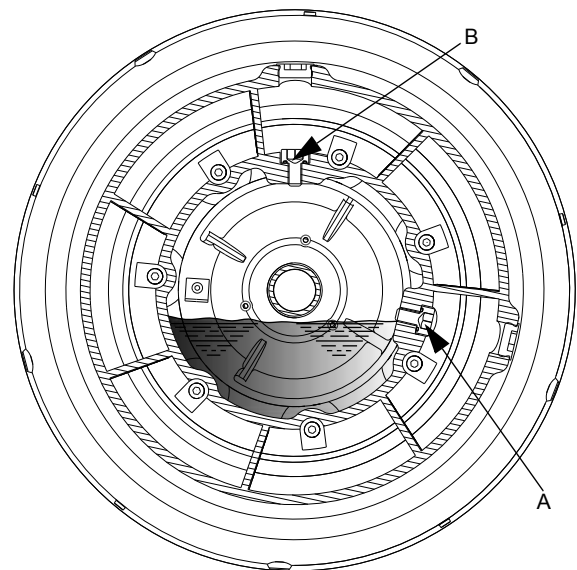

Fig. 26 Sectional view of pump showing oil plugs

TM06 2595 4414

**Warning**

When loosening plug A of the oil chamber, note that pressure may have built up in the chamber. Do not remove the screw until the pressure has been fully equalised.

4. Place a clean container under the pump to collect all the drained-off oil. Drain the oil from the pump.
5. Check the amount of drained oil and notice the condition of the oil. The oil becomes greyish white like milk if it contains water.
 - Clear oil can be reused.
 - Emulsified oil must be changed and disposed of.

Note

Dispose of used oil in accordance with local regulations.

6. Remove the drain pipe and valve.
7. Replace the O-ring on plug A and tighten securely.
8. Fill the oil chamber with oil to the correct level. Refit plug B with a new O-ring and tighten securely. See fig. 27.

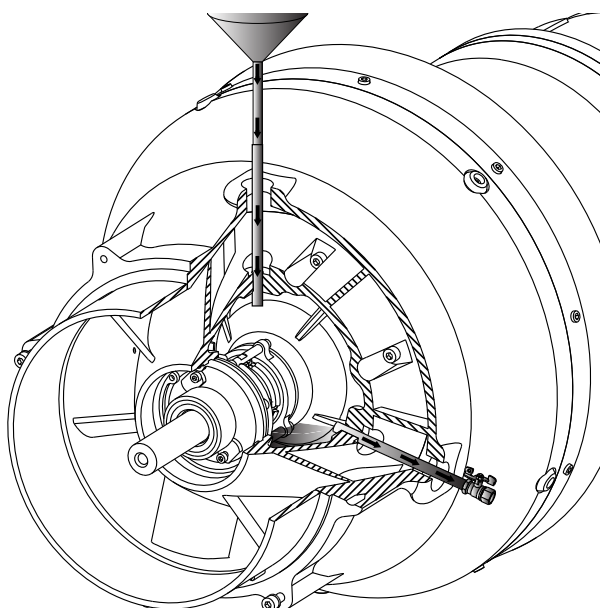

TM06 2587 4414

Fig. 27 Drain and filling pipes for oil change, KPL 500-600.

10.5.2 KPL 650, KWM 600

Position numbers of parts refer to sections 20. *Drawings*, 21. *List of materials* and 22. *Exploded views*.

Proceed as follows:

1. Place the pump in horizontal position. See fig. 28.
2. Loosen and remove both plugs (pos. 193a).
3. Remove only the lower oil plug (pos. 193).
4. Immediately mount a pipe with valve in the oil drain hole to avoid any unnecessary oil spillage. Make sure the valve is closed.
5. Remove the upper oil plug (pos. 195).
6. Place a clean container under the drain pipe to collect all the drained-off oil. Open the valve and drain the oil from the pump.
7. Check the amount of drained oil and notice the condition of the oil. The oil becomes greyish white like milk if it contains water.
 - Clear oil can be reused.
 - Emulsified oil must be changed and disposed of.

Note

Dispose of used oil in accordance with local regulations.

8. Remove the drain pipe and valve.
9. Replace the O-ring on the plug (pos.193) and tighten securely.
10. Mount a pipe with funnel in the plug hole (pos. 195). See fig. 28.

11. Fill in the correct amount of oil.

12. Replace the filling pipe with plug (pos. 195) and new O-ring (pos. 195a) and tighten the plug securely.

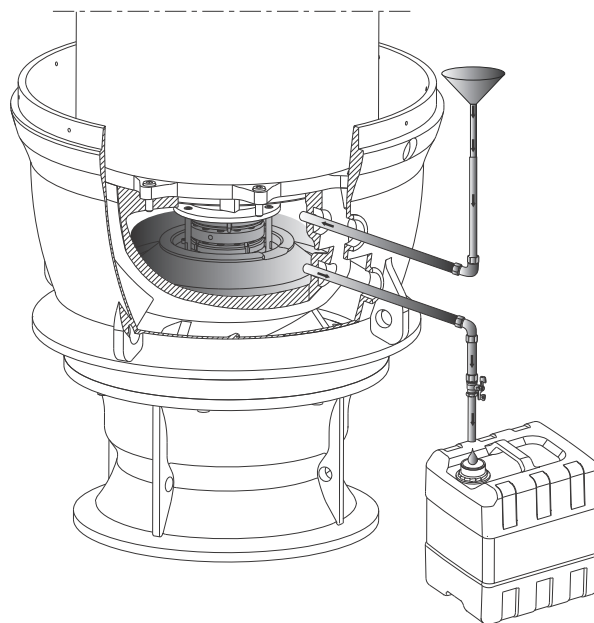

TM06 2844 4714

Fig. 28 Drain and filling pipes, KPL 650 and KWM 600.

10.5.3 KPL 700-1800, KWM 700-1600

These pumps have an oil service kit which can be ordered in Grundfos. Use order no. 98887554.

With this kit it is easy to check the oil level. Take an oil sample and change the oil, if necessary, without having to remove any part of the pump.

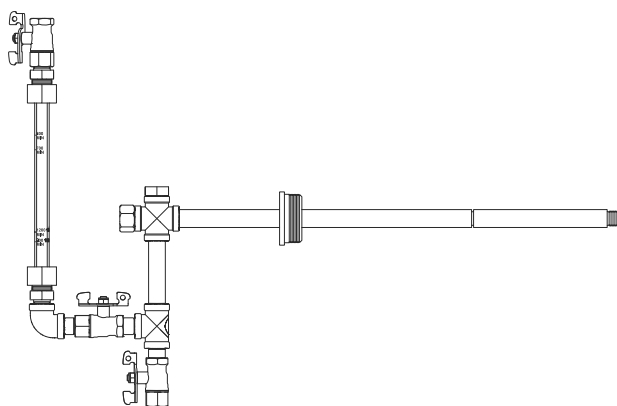

TM06 2584 4414

Fig. 29 Pipe connection, column 700-800

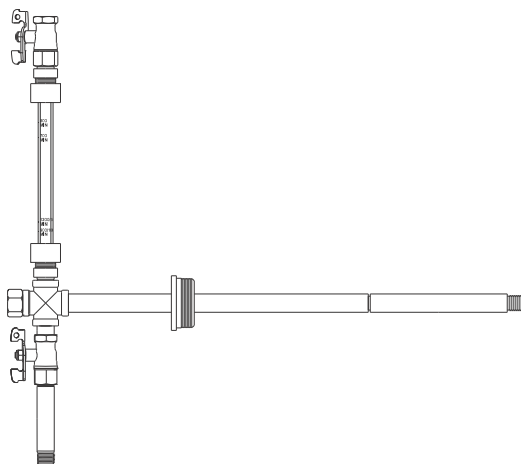

TM06 2583 4414

Fig. 30 Pipe connection, column 900-1800

11. Power-lock®

Warning

Caution

Before removing Power-lock®, place the pump in horizontal position, and secure the impeller by means of a strap and a crane



Warning

Before removing Power-lock®, make sure that there is no thrust on the propeller/impeller.

11.1 Removing Power-lock®

MxxDR200

1. Loosen the screws evenly in a diagonal pattern and in sequence according to the table in section 18. Power-lock®.
2. If possible, remove Power-lock® from the hub. If this is not possible, continue from point 3 below.
3. Carefully clean the hub and the shaft and lightly tap Power-lock® with a rubber hammer.
4. Insert the screws into the dismantling threads and cross-tighten gradually and regularly, until the rings are loose.
5. If Power-lock® is still stuck, find the root cause for this. It might be deformation or wrong assembly.

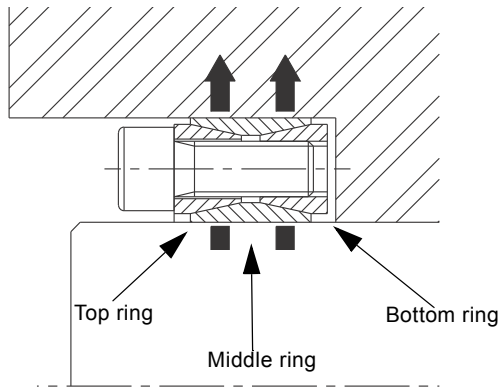

Fig. 31 MxxDR200

MxxDR400

1. Loosen and remove all screws.
2. Use half of the screws just removed and mount them in the dismantling threads of the top ring. See fig. 34. Cross-tighten the screws gradually and regularly until the top ring comes loose and can be removed.
3. Mount the other half of the screws in the dismantling threads of the middle ring. Cross-tighten the screws gradually and regularly until the middle ring comes loose and can be removed.
4. Remove the bottom ring.

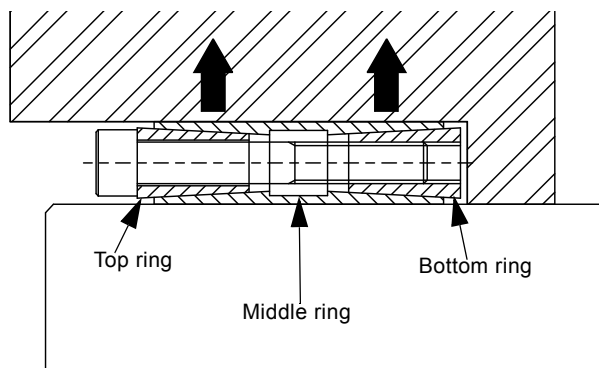

Fig. 32 MxxDR400

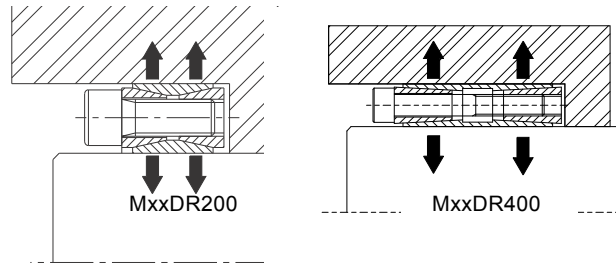

Fig. 33 Sectional view Power-lock® DR200 / DR400

11.2 Mounting Power-lock®

1. Check the condition of Power-lock®.
2. Carefully clean the hub and shaft surfaces and apply a light oil film.

Note

Do not use any oil with molybdenum bisulphate, high-pressure additives or grease because this will reduce the friction coefficient.

3. Carefully clean the screws and Power-lock® and apply a thin layer of oil.
4. Insert Power-lock® into the propeller/impeller hub.
5. Mount a straight piece of metal with a hole in the middle, and tighten down the propeller/impeller. See fig. 35.
6. Cross-tighten gradually 1/4 - 1/2 - 1/1 of the torque, see example in fig. 34, and as section 18. Power-lock® illustrates until correct torque has been reached. See fig. 7 for tightening torque for Power-lock®.

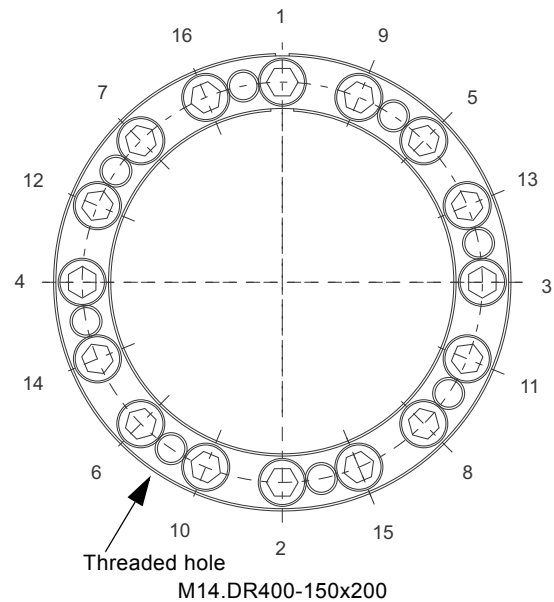

Fig. 34 Example of tightening sequence.

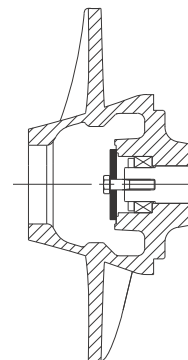

Fig. 35 Tool for keeping propeller/impeller in place

12. Dismantling KPL 500-800, KWM 600-700

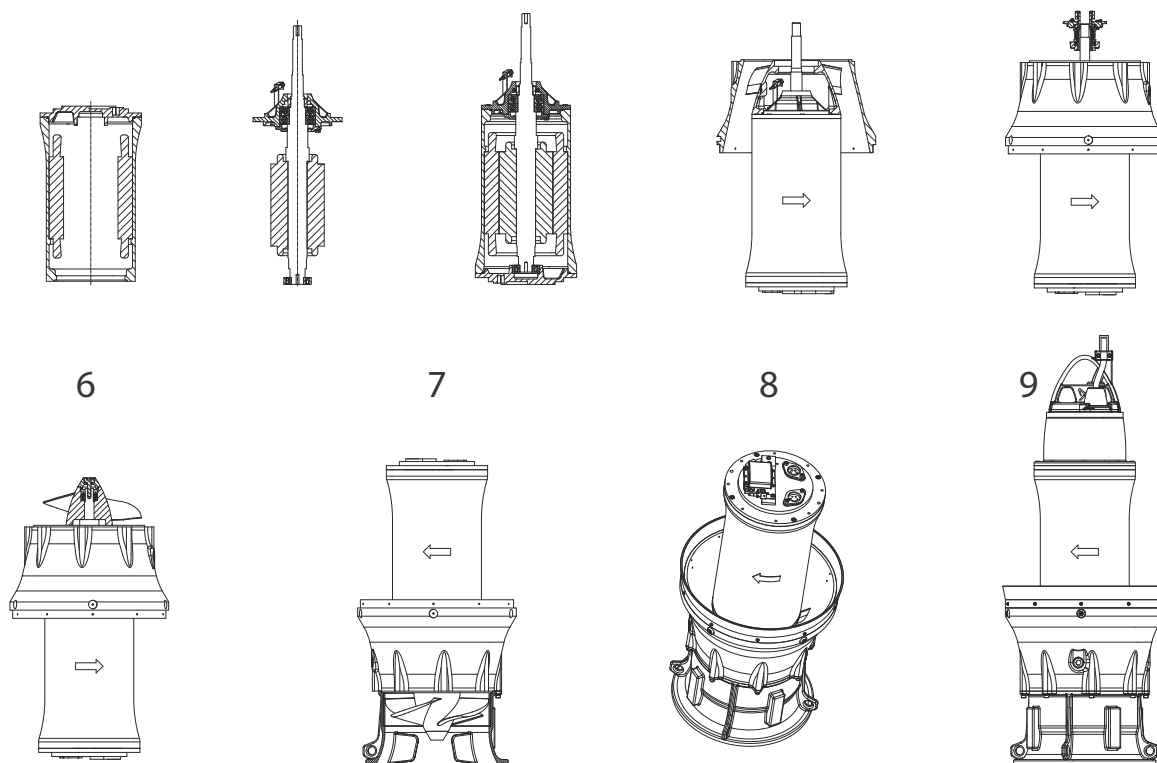

Fig. 36 Assembly order, column pipe diameter 500 to 800

Caution *If service includes oil change or removal of the shaft seal, the oil must be removed at the beginning of the service job.*

Position numbers of parts refer to section [20. Drawings](#), [21. List of materials](#) and [22. Exploded views](#). Position letters of tools refer to section [6. Service tools](#).

12.1 Removing the cables and the motor top cover

If it is necessary to remove the cable entry, skip this part and go to section [12.2 Removing the power cable/sensor cable](#).

KPL 500-600

1. Loosen and remove the screw (pos. 178). See fig. [40](#).
2. Lift the motor top cover (pos. 164a) 15 cm and cut both power wires and sensor wires close to the wire joints with the side cutter (pos. M).
3. Disconnect the earth cable from the motor top cover.

Note *Remember to mark the wires before cutting.*

4. Lift away the motor top cover.

KPL 650-800, KWM 600-700

1. Loosen and remove the screws (pos. 166). See fig. [42](#).
2. Remove the terminal box cover (pos. 164).
3. Disconnect the power cables and sensor cables from the terminal board (pos. 176a).
4. Remove the screw (pos. 178).
5. Disconnect the earth conductors.
6. Lift away the motor top cover (pos. 164a) by the lifting bracket (pos. 190).

12.2 Removing the power cable/sensor cable

Removing the cable clamps

1. Loosen and remove the screws (pos. 180a). See section 22. Exploded views.
2. Remove the cable clamps. See fig. 37.

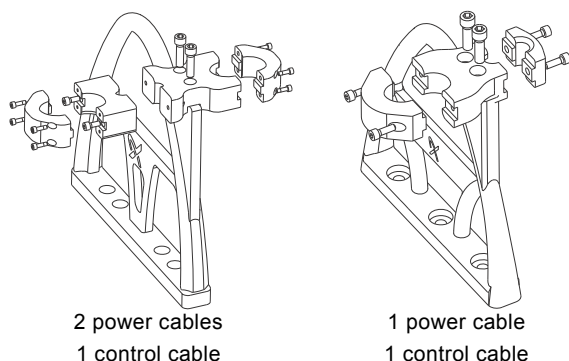

Fig. 37 Cable clamps.

KPL 500-600

3. Loosen and remove the screw (pos. 181a). See fig. 38.
4. Lift the cable entry 10-15 cm and cut both power wires and sensor wires close to wire joints with the side cutter (pos. M).

KPL 650-800, KWM 600-700

1. Loosen and remove the screws (pos. 166).
2. Remove the terminal box cover (pos. 164).
3. Disconnect the power cable and sensor cable from the terminal board (pos. 176a).
4. Loosen and remove the screws (pos. 181a).
5. Lift away the cables.

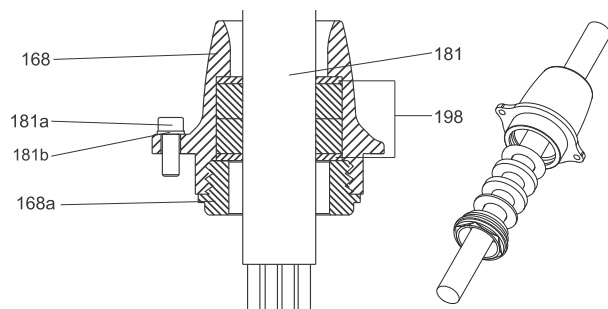

Fig. 38 Cable entry, power cable

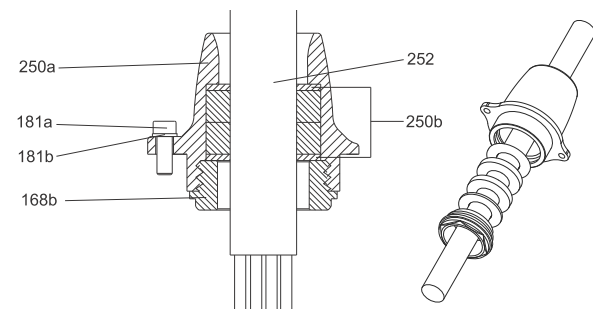

Fig. 39 Cable entry, sensor cable

12.3 Removing the cable entries

KPL 500-800, KWM 600-700

Power cable, see fig. 38

1. Remove the power cable entry from the terminal box cover (pos. 164a). See section 12.2 Removing the power cable/sensor cable.
2. Place the cable entry (pos. 168) in a vice.
3. Unscrew the lower cable entry (pos. 168a).
4. Push the cable together with rubber seal (pos. 198) out of plug.
5. Remove rubber seals (pos. 198) from the cable.
6. Pull and remove the cable (pos. 181) from the cable entry.

Sensor cable, see fig. 39

1. Remove the sensor cable entry from the terminal box cover (pos. 164a). See section 12.2 Removing the power cable/sensor cable.
2. Place the cable entry (pos. 250a) in a vice.
3. Unscrew the lower cable entry (pos. 168b).
4. Push the cable together with rubber seals (pos. 250b) out of plug.
5. Remove the rubber seals (pos. 250b) from the cable.
6. Pull and remove the sensor cable (pos. 252) from the cable entry.

12.4 Removing the motor top cover

KPL 500-600

1. Remove the cables with the cable entry.
2. Remove the screw (pos. 178).
3. Lift away the motor top cover (pos. 164a) by the lifting bracket (pos. 190).
4. Disconnect the moisture switch (pos. 520), the Pt100 bearing temperature sensor (pos. 288) and the PVS 3 (pos. 528) sensor wire from SM 113, if SM 113 fitted.
5. Loosen and remove the moisture switch, the Pt100 bearing temperature sensor and the PVS 3 sensor. See fig. 41.

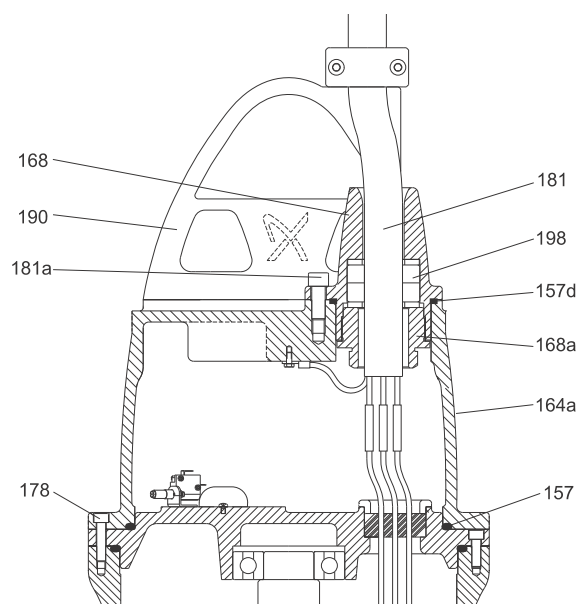

Fig. 40 Top cover details, KPL 500-600.

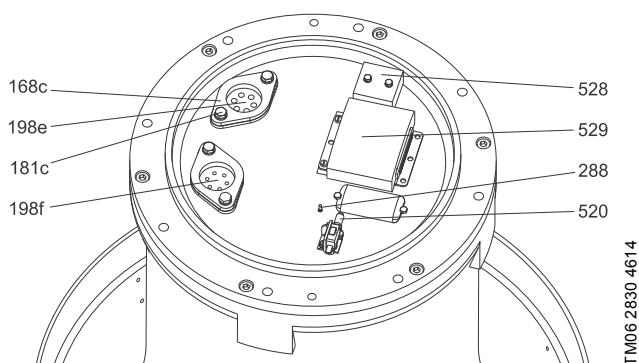

Fig. 41 Position of sensors, KPL 500-600

KPL 650-800, KWM 600-700

1. Remove the cables from the motor top cover.
2. Remove the screw (pos. 178). See fig. 42.
3. Lift away the motor top cover (pos. 164a) by the lifting bracket (pos. 190).
4. Disconnect the moisture switch (pos. 520), the Pt100 bearing temperature sensor (pos. 288) and the PVS 3 (pos. 528) sensor wire from SM 113, if SM 113 fitted.
5. Loosen and remove the moisture switch, the Pt100 bearing temperature sensor and the PVS 3 sensor. See fig. 42.
6. Loosen and remove the terminal screws (pos. 176b).
7. Remove the terminal board (pos. 176a).

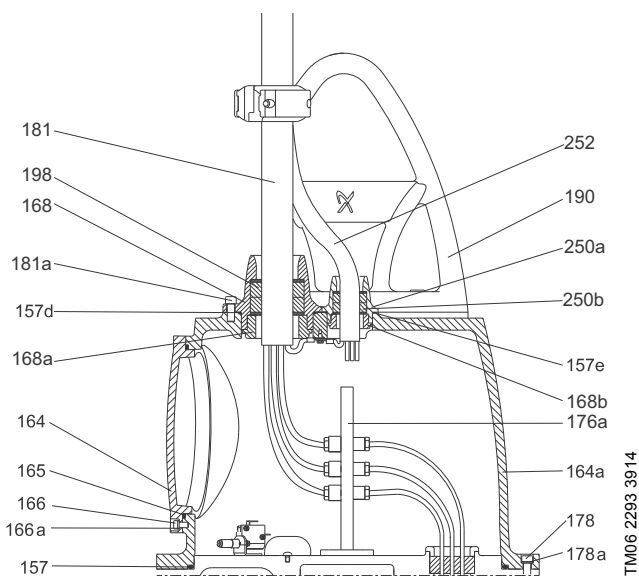

Fig. 42 Top cover details, KPL, KWM 650-1800

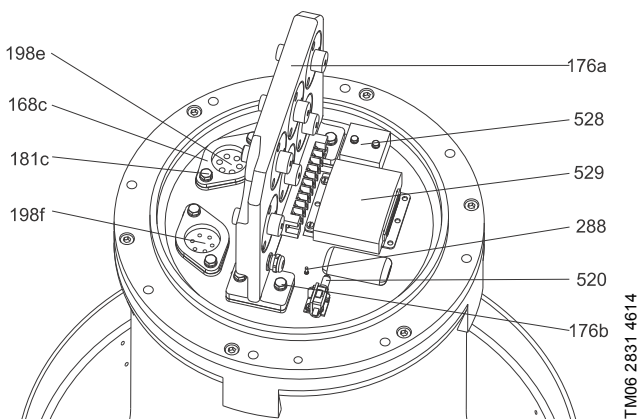

Fig. 43 Position of sensors KPL, KWM 650-1800

12.5 Removing the suction casing

KPL 500-800, KWM 600-700

1. Turn the pump upside down, placing the upper bearing cover on wooden beams.
2. Mount shackles and/or lifting straps on the suction casing.
3. Loosen and remove the screws (pos. 26).
4. Lift away the suction casing.

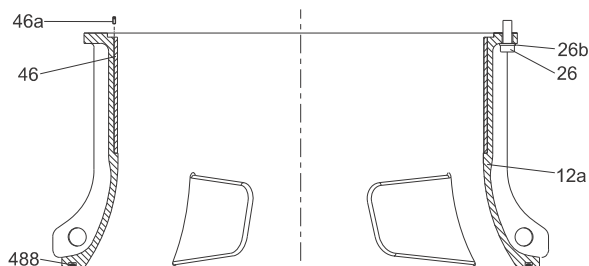

Fig. 44 Suction casing, KPL

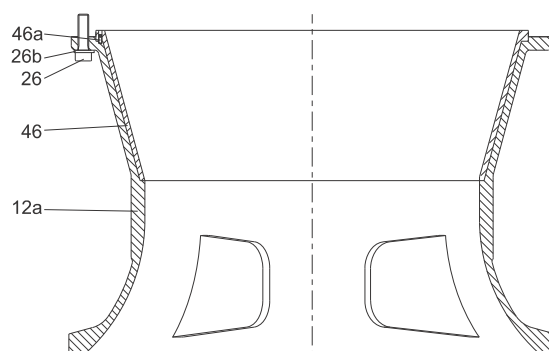

Fig. 45 Suction casing, KWM, medium head

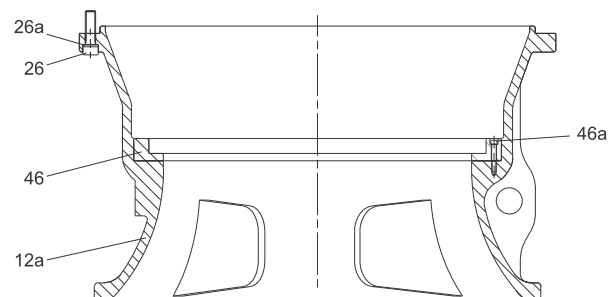

Fig. 46 Suction casing, KWM, high head

12.6 Removing the wear ring

KPL 500-800, KWM 600-700

1. Place the suction casing on wooden beams with the wear ring facing downwards. Make sure the wooden beams are placed in such way that there is access to all set screws (pos. 46a).
2. Loosen and remove the set screws (pos. 46a).
3. Lift the suction casing, and the wear ring will separate from the suction casing. If not, lift the suction casing slightly over the beams and loosen the wear ring by means of a hammer.

12.7 Removing the propeller/impeller

KPL 500-650, KWM 600-700



Warning

Before dismantling Power-lock®, make sure that there is no thrust on the propeller/impeller.

1. Loosen and remove the screw (pos. 67a).
2. Remove the cap (pos. 66).
3. Loosen and remove Power-lock® (pos. 118). See section 11. Power-lock®.
4. Lift away the propeller/impeller by means of straps.

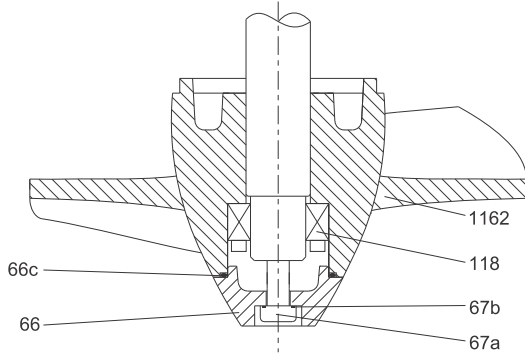

Fig. 47 Propeller, KPL 500-650

KPL 700-800

1. Loosen and remove the screw (pos. 67a).
2. Remove the cap (pos. 66).
3. Loosen and remove the support screw (pos. 67).
4. Remove the cover for Power-lock® (pos. 66a).
5. Loosen and remove Power-lock® (pos. 118). See section 11. Power-lock®.
6. Lift away the propeller/impeller by means of straps.

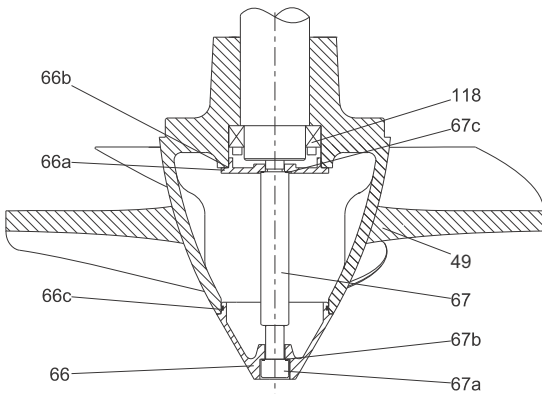

Fig. 48 Propeller, KPL 700-1800

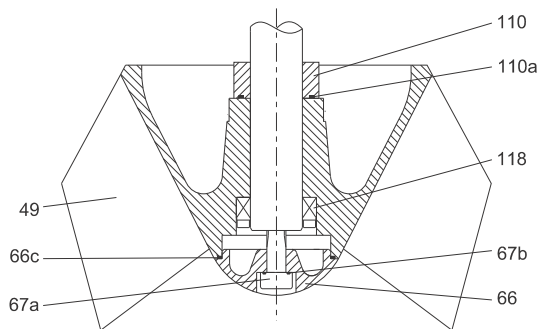

Fig. 49 Impeller, KWM, medium head

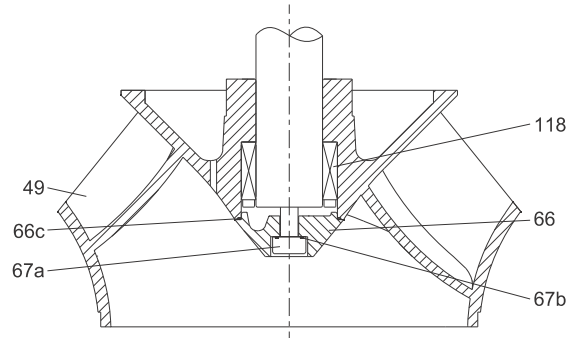

Fig. 50 Impeller, KWM, high head

12.8 Removing the shaft seal

KPL 500

1. Gently remove the seal ring (pos. 104).
2. Loosen the screw (pos. 105f) and engage the shaft seal locks (pos. 105e), then tighten the screw (pos. 105f) again. See fig. 51.
3. Loosen the set screws (pos. 104b).
4. Remove the circlip (pos. 77a).
5. Insert screws into the dismantling thread and tighten equally until the cartridge comes loose.
6. Remove the shaft seal (pos. 105).

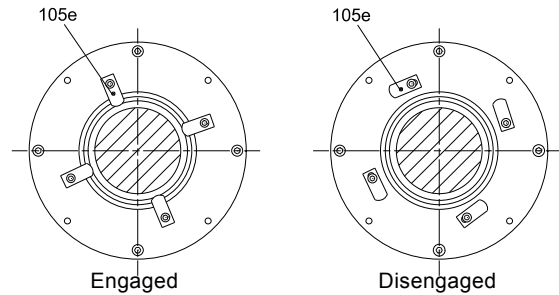

Fig. 51 Shaft seal locks

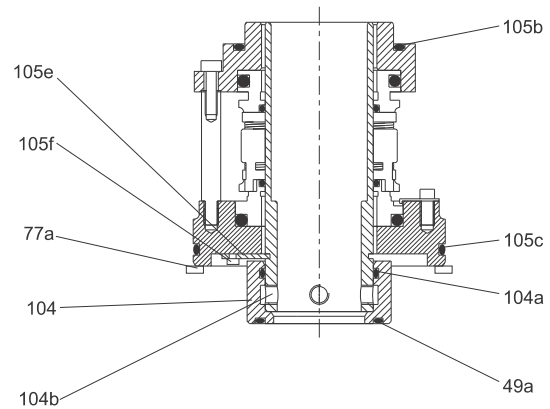
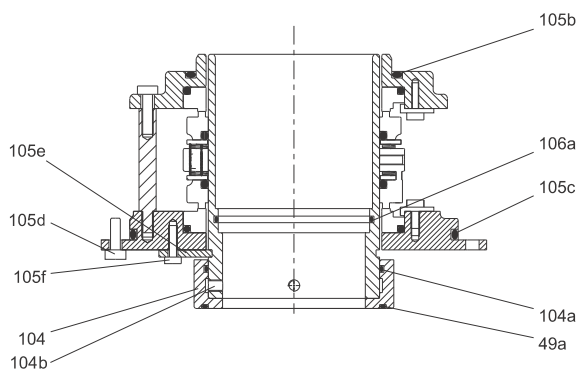

Fig. 52 Shaft seal, KPL 500

KPL 600-800, KWM 600-700

1. Gently remove the seal ring (pos. 104).
2. Loosen the screw (pos. 105f) and engage the shaft seal locks (pos. 105e), then tighten the screw (pos. 105f) again. See fig. 51).
3. Loosen the set screws (pos. 104b).
4. Loosen and remove the screws (pos. 105d).
5. Mount the screws (pos. 105d) in the dismantling threads placed next to their normal position. See fig. 51. Tighten the screws equally until the cartridge comes loose.
6. Remove the shaft seal (pos. 105).

**Fig. 53** Shaft seal, KPL, KWM 600-1800

TM06 2309 3914

12.9 Removing the discharge casing

If the turbulence optimiser and/or the discharge casing protector are worn down or defective, Grundfos recommend a change of these. See fig. 54 for a more detailed view.

Removing the turbulence optimiser

1. Loosen and remove the screw (pos. 117b).
2. Lift away the turbulence optimiser (pos. 117a). See fig. 54.

Removing the discharge casing protector

1. Loosen and remove the screw (pos. 117d).
2. Remove the discharge casing protector (pos. 117c). See fig. 54.

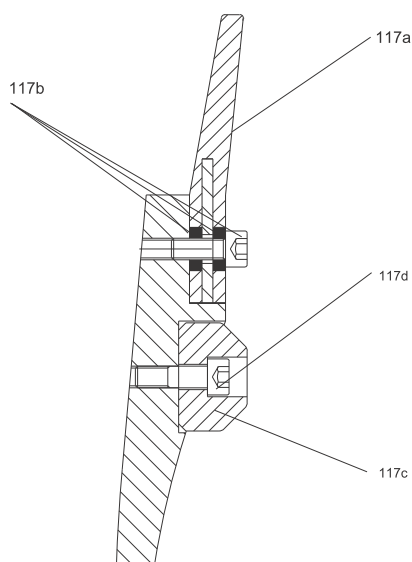
**Fig. 54** Turbulence optimiser and discharge casing protector

TM06 2303 4614

KPL 500-800, KWM 600-700

1. Mount 3 or 4 eyebolts in the threads where the suction casing screws (pos. 26) were mounted.
2. Mount a wire in each of the three eyebolts and in the hook of a crane.
3. Loosen and remove the screws (pos. 184a).
4. Lift away the pump discharge casing.

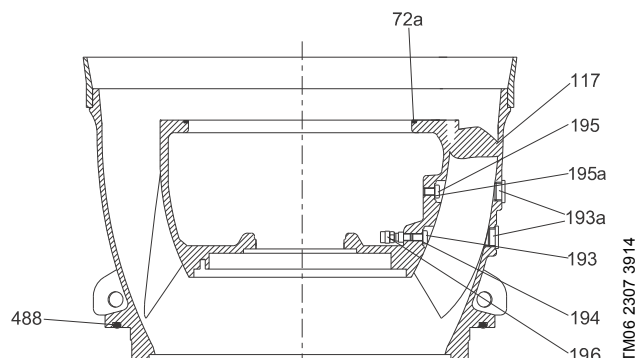
**Fig. 55** Discharge casing, KWM

TM06 2307 3914

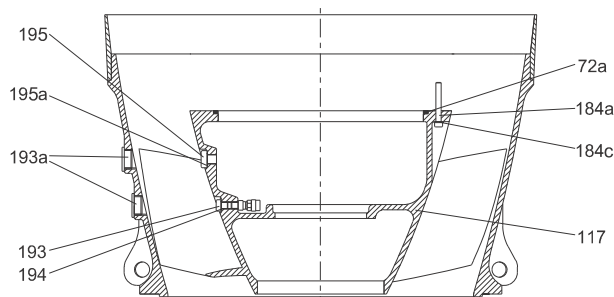
**Fig. 56** Discharge casing, KPL

TM06 2306 3914

12.10 Removing the rotor with bearings**KPL 500-800, KWM 600-700**

1. Mount an eyebolt in the drive end of the shaft and fit the hook of a crane in it.
2. Loosen and remove the screw (pos. 184).
3. Gently lift up the rotor making it possible to gain access to the cables and the moisture switch (pos. 521).
4. Disconnect the following wires:
 - moisture switch
 - bearing temperature sensor
 - WIO sensor with transient protector, if fitted.
5. Lift away the rotor.

12.11 Removing the lower bearings

KPL 500-800, KWM 600-700

Place the rotor with bearing bracket in vertical position on a suitable, stable workbench.

1. Loosen the cable gland (pos. 523a) from both sides of the lower bearing bracket (pos. 155).
2. Disconnect the WIO sensor from the transient protector and cut off the cable terminals of the WIO sensor (pos. 523). Then pull the cable of the WIO sensor out of the bearing bracket.

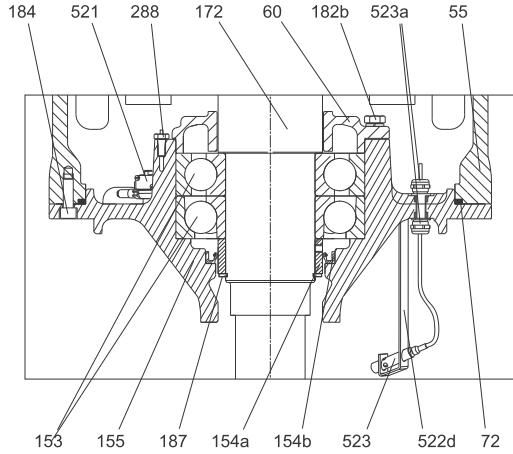

Fig. 57 Lower bearing, KPL 500-800, KWM 600-700

3. Loosen and remove the screw for the WIO sensor bracket (pos. 522d) and remove the WIO sensor with bracket.
4. Loosen and remove the lower bearing temperature sensor (pos. 288).
5. Loosen and remove the screws (pos. 521b) for the moisture switch (pos. 521).
6. Mount three eyebolts, placed at 120 ° angles. Connect three wires from the eyebolts to a shackle. Insert a crane hook into the shackle.
7. Loosen and remove the screws (pos. 182b) for the bearing cover (pos. 60).
8. Heat up the bearing cover carefully until the bracket can be removed.
9. Gently lift the bearing bracket away from the bearings.
10. Let the shaft with bearings cool down.
11. Remove the circlip (pos. 187).
12. Loosen the set screw in the shaft sleeve (pos. 154a). See fig. 57.
13. Press out the bearings (pos. 153) in a press.
14. Knock out the seal ring (pos. 154b) from the bearing bracket (pos. 155) using a hammer and a punch.

12.12 Removing the upper bearing and bearing bracket

KPL 500-800, KWM 600-700

1. Lift the rotor from the stator housing. Both inner and outer ring of the upper bearing will follow the shaft.
2. Remove the upper bearing (pos. 154) from the shaft using a puller.
3. Place the stator housing (pos. 55) in vertical position with the upper bearing bracket upwards. See fig. 36.
4. Loosen and remove the screw (pos. 181c) and remove the cable entries for the stator housing (pos. 168c).
5. Pull out the cable gland (pos. 198e, 198f).
6. Loosen and remove the screw (pos. 183) and lift out the bearing bracket (pos. 61c) while carefully guiding all cables through the cable bushing.

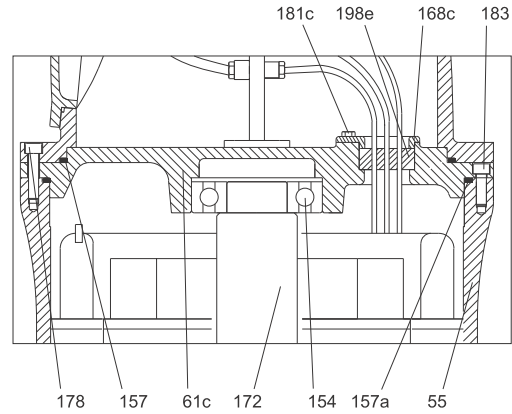

Fig. 58 Upper bearing, KPL 500-800, KWM 600-700

13. Assembling KPL 500-800, KWM 600-700

Before assembling

- Clean and check all parts.
- Replace defective parts with new parts.
- Order the necessary service kits.
- Always replace gaskets and O-rings.

During assembling

- Lubricate and tighten screws, nuts and O-rings according to section 7. *Tightening torques and lubricants*.

13.1 Mounting the upper bearing bracket

KPL 500-800, KWM 600-700

1. Place the stator housing (pos. 55) on two wooden beams.
2. Lubricate and fit the O-ring (pos. 157a) on the upper bearing bracket (pos. 61c).
3. Place the bearing bracket (pos. 61c) on the stator housing (pos. 55) and tighten the screws (pos. 183).
4. Place the wires correctly through each cable bushing, so that they fit the correct cable gland (pos. 198f, 198e).
5. Fit the cable glands (pos. 198f, 198e) and cable entries (pos. 168c).
6. Fit the screws (pos. 181c) and tighten according to section 7. *Tightening torques and lubricants*.
7. Turn the stator housing (pos. 55) with the upper bearing bracket (pos. 61c) upside down.

13.2 Mounting the bearings and the lower bearing bracket

KPL 500-800, KWM 600-700

1. Heat the upper bearing (pos. 154) to 120 °C and mount it on the shaft.
2. When the upper bearing has cooled down, lubricate the outer ring with Castrol Optimol Paste White T.
3. Place the lower bearing bracket cover on the shaft.
4. Heat both lower bearings (pos. 153) to 120 °C and mount them on the shaft.
5. Lubricate the shaft sleeve (pos. 154a) with oil and mount it on the shaft and tighten the set screws according to section 7. *Tightening torques and lubricants*.
6. Mount the circlip (pos. 187) on the shaft.
7. Press the seal ring (pos. 154b) into the lower bearing bracket (pos. 155). See fig. 59.
8. Heat up the lower bearing bracket to 120 °C and press the shaft with bearings into the bearing bracket (pos. 155).
9. Mount the screws (pos. 182b) and tighten them according to section 7. *Tightening torques and lubricants*.

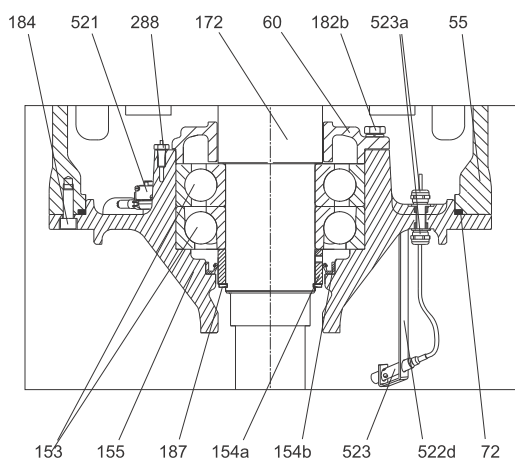

Fig. 59 Lower bearing, KPL 500-800, KWM 600-700

10. Mount the moisture switch (pos. 521).
11. Mount the lower bearing temperature sensor (pos. 288).
12. Mount the WIO sensor bracket (pos. 522d) and the WIO sensor (pos. 523).

Note

Make sure the WIO sensor is placed correctly in relation to the direction of rotation. See fig. 60.

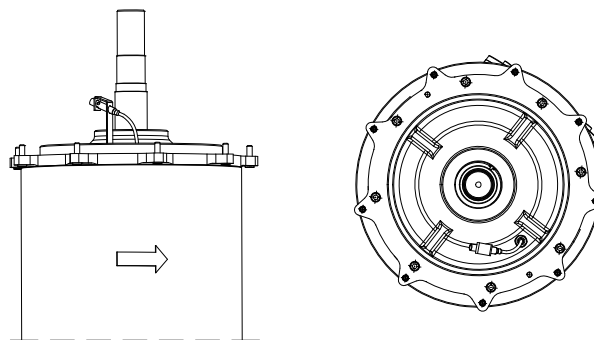

Fig. 60 Correct position of the WIO sensor

13. Mount the cable gland (pos. 523a) and take the WIO sensor cable through the cable gland, making sure that the cable length on the WIO sensor side is correct. The cable must not interfere with the shaft seal.
14. Tighten the cable gland (pos. 523a).
15. Lubricate and fit the O-ring (pos. 72) on the lower bearing bracket (pos. 155).
16. Lower the shaft (pos. 172) with the lower bearing housing until there is a gap of 15-20 cm between the stator housing (pos. 55) and the lower bearing bracket (pos. 155).
17. Connect the sensor wires according to the wiring diagrams. See section 20. *Drawings*.
18. Lower the shaft into place in the stator housing, making sure the upper bearing is centred in the upper bearing bracket while lowering the shaft into place.
19. Mount the screws (pos. 184) and tighten them according to section 7. *Tightening torques and lubricants*.

Note

Do not pinch the cables while lowering the shaft.

13.3 Mounting the discharge casing

KPL500-800, KWM 600-700

1. Lubricate and fit the O-ring (pos. 72a) on the lower bearing bracket (pos. 155).
2. **KPL 500 only:** Fit the seal bracket (pos. 186a) and tighten the screw (pos. 186) according to section 7. *Tightening torques and lubricants*.
3. **KPL 700-800 and KWM 700:** Mount the non-return valve (pos. 196) in the discharge casing.
4. Lower the discharge casing (pos. 117) into place.
5. Mount the screws (pos. 184a) and tighten them according to section 7. *Tightening torques and lubricants*.
6. **KWM 600-700 only:** Lubricate and mount the O-ring (pos. 488) on the discharge casing (pos. 117).

Note

The turbulence optimiser and the discharge casing protector will be mounted at the end of the assembly procedure.

TM06 2301 3914

13.4 Mounting the shaft seal

KPL 500

1. Make sure the shaft seal locks (pos. 105e) are engaged. See fig. 63.
2. Lubricate and fit the O-rings (pos. 105b and 105c).
3. Push the shaft seal (pos. 105) on to the shaft.

Note Make sure the shaft seal is engaged with the seal bracket. See fig. 61.

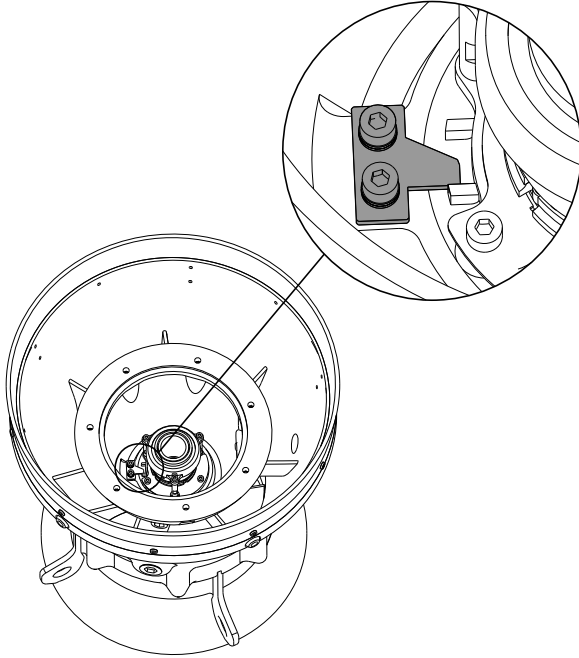

Fig. 61 KPL 500 seal bracket

4. Fit the circlip (pos. 77a) with the circlip pliers (C).
5. Disengage the shaft seal locks (pos. 105e) and retighten the screw (pos. 105f). See fig. 63.
6. Tighten the set screws (pos. 104b) according to section 7. *Tightening torques and lubricants* so that the shaft seal liner is engaged with the shaft.
7. Lubricate and fit the O-rings (pos. 104a and 49a) in the seal ring (pos. 104).
8. Fit the seal ring (pos. 104).

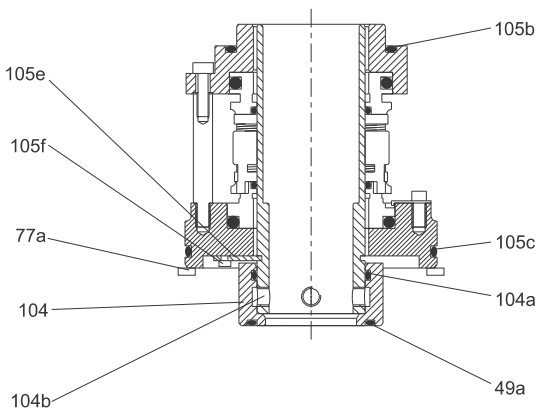

Fig. 62 Shaft seal, KPL 500

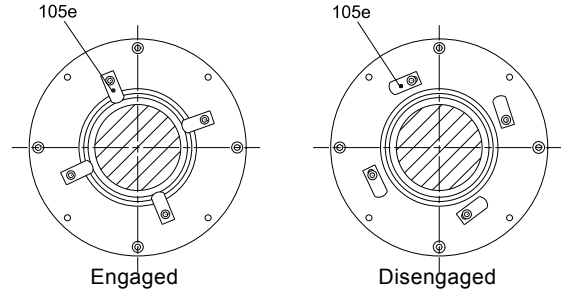

Fig. 63 Shaft seal locks

KPL 600-800, KWM 600-700

1. Make sure the shaft seal locks (pos. 105e) are engaged. See fig. 63.
2. Lubricate and fit the O-rings (pos. 105b, 105c and 106a).
3. Push the shaft seal (pos. 105) into place on the shaft.
4. Mount the screws (pos. 105d) and tighten them according to section 7. *Tightening torques and lubricants*.
5. Disengage the shaft seal locks (pos. 105e) and retighten the screw (pos. 105f). See fig. 63.
6. Tighten the set screws (pos. 104b) according to section 7. *Tightening torques and lubricants* so that the shaft seal liner is engaged with the shaft.
7. Lubricate and fit the O-rings (pos. 104a and 49a) in the seal ring (pos. 104).
8. Fit the seal ring (pos. 104).

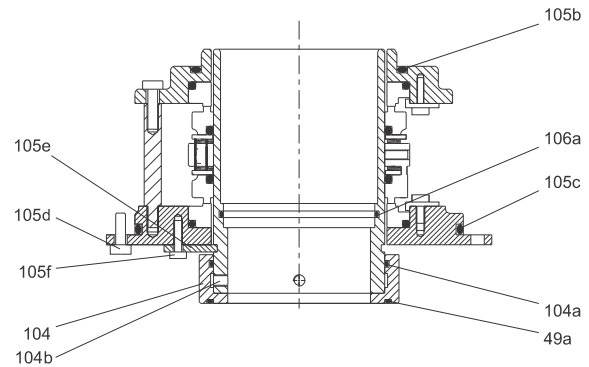

Fig. 64 Shaft seal, column 600-1800

TM06 2622 4414

TM06 2308 3914

TM06 2501 4414

TM06 2309 3914

13.5 Mounting the propeller/impeller

KPL 500-650

1. Fit the propeller (pos. 49).
2. Fit Power-lock®.
3. Force the propeller into position using a rectangular piece of metal in order to make sure that the impeller is mounted correctly. See fig. 65.

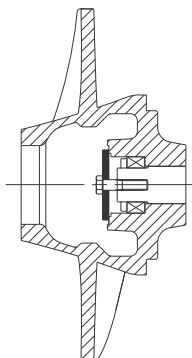

Fig. 65 Mounting of propeller/impeller

4. Tighten Power-lock® according to section 11. *Power-lock®*.
5. Lubricate and fit the O-ring (pos. 66b) on the propeller cap (pos. 66)
6. Lubricate and fit the O-ring (pos. 67b) on the screw (pos. 67a)
7. Mount the propeller cap (pos. 66), fit the screw (pos. 67a) and tighten it according to section 7. *Tightening torques and lubricants*. See fig. 66.

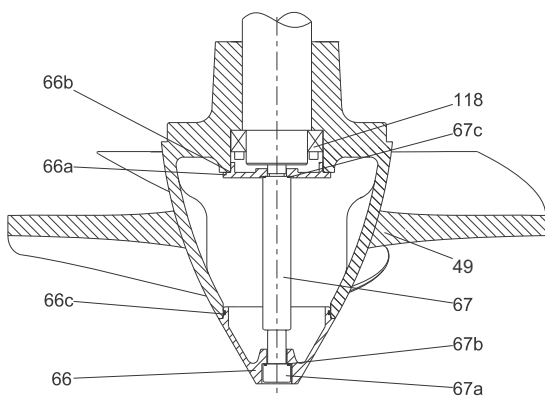

Fig. 66 Propeller, KPL 700-1800

KPL 700-800

1. Fit the propeller (pos. 49).
2. Fit Power-lock®.
3. Force the propeller into position using a rectangular piece of metal in order to make sure that the impeller is mounted correctly. See fig. 65.
4. Tighten Power-lock® according to section 11. *Power-lock®*.
5. Lubricate and fit the O-ring (pos. 66b) on the Power-lock® cover (pos. 66a).
6. Lubricate and fit the O-ring (pos. 67c) on the support screw (pos. 67).
7. Mount the Power-lock® cover (pos. 66a) and fit the support screw (pos. 67) and tighten it according to section 7. *Tightening torques and lubricants*.
8. Mount the propeller cap (pos. 66), the O-ring (pos. 66c), the screw (pos. 67a) and tighten it according to section 7. *Tightening torques and lubricants*.

KWM 600-700

1. Mount the water chamber (pos. 77) and fit the screw (pos. 26a) and tighten it according to section 7. *Tightening torques and lubricants*.
2. **KWM 700 M only:** Mount the intermediate ring (pos. 110) and the O-ring (110a).
3. Fit the impeller (pos. 49).
4. Fit Power-lock®. See section 11. *Power-lock®*.
5. Force the impeller into position using a rectangular piece of metal in order to make sure that the impeller is mounted correctly. See fig. 65.
6. Tighten Power-lock® according to section 11. *Power-lock®*.
7. Lubricate and fit the O-ring (pos. 66c) on the impeller cap (pos. 66). See figs 67 and 68.
8. Lubricate and fit the O-ring (pos. 67b) on the screw (pos. 67a).
9. Mount the impeller cap (pos. 66), fit the screw (pos. 67a) and tighten it according to section 7. *Tightening torques and lubricants*.

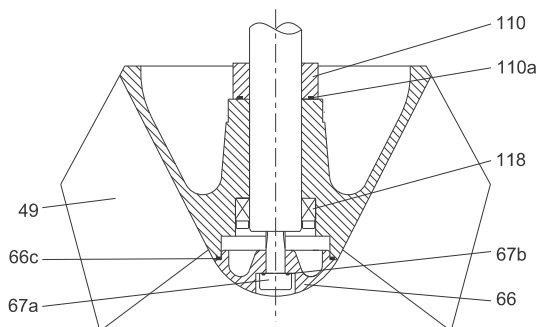

Fig. 67 Impeller, KWM, medium head

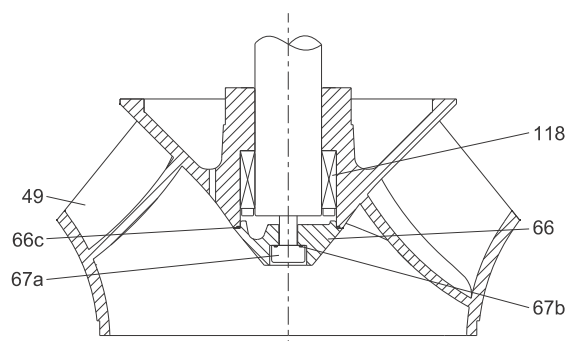

Fig. 68 Impeller, KWM, high head

TM06 2505 4414

TM06 2312 3914

TM06 2313 3914

TM06 2314 3914

13.6 Mounting the suction casing and the wear ring

1. Place the suction casing (pos. 12a) on two wooden beams.
2. Lower and fit the wear ring (pos. 46) into its place. See figs 69-71.
3. Tap new threaded holes and mount the set screws (pos. 46a) and tighten them according to section 7. *Tightening torques and lubricants*.
4. Turn the pump to correct upright position and fit the pump in the suction casing (pos. 12a). See fig. 36, drawings no 6 and 7.
5. Mount the screws (pos. 26) and tighten them according to section 7. *Tightening torques and lubricants*.

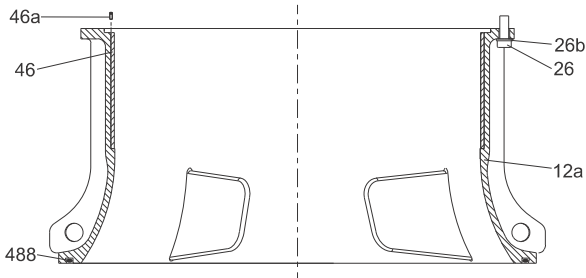

Fig. 69 Suction casing, KPL

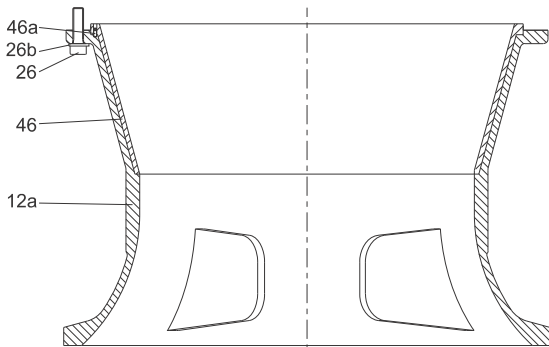

Fig. 70 Suction casing, KWM, medium head

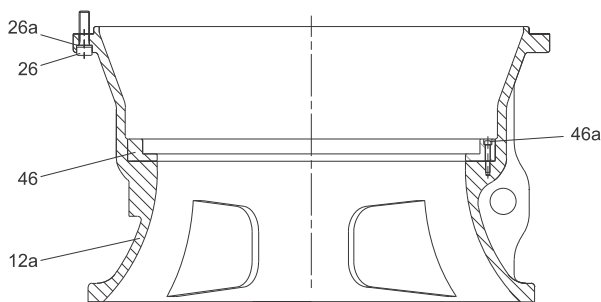

Fig. 71 Suction casing, KWM, high head

13.7 Mounting the sensors

1. Mount the sensors according to fig. 72 or 73.
2. **KPL 650-800, KWM 600-700 only:** Mount the terminal board (pos. 176a) and fit the screws (pos. 176b) and tighten them according to section 7. *Tightening torques and lubricants*.

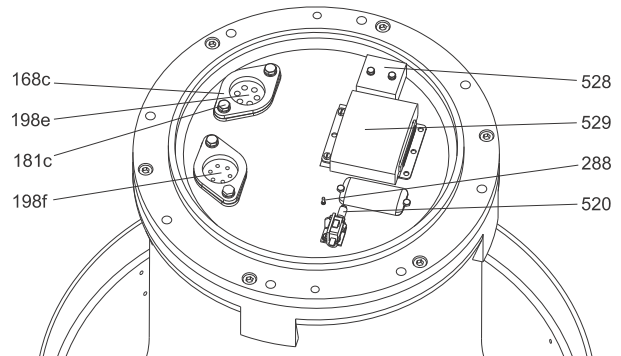

Fig. 72 Position of sensors, KPL 500-600

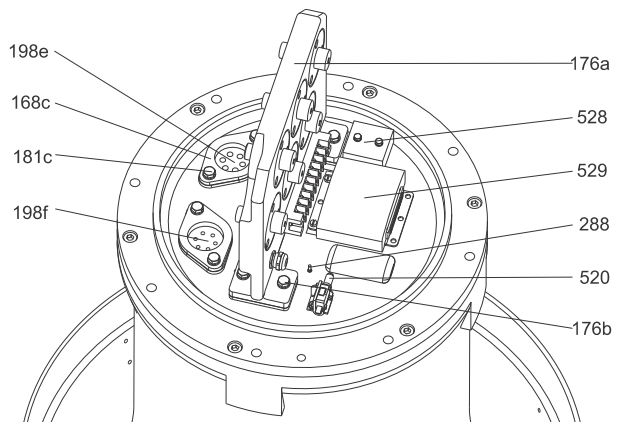

Fig. 73 Position of sensors, column 650-1800

13.8 Mounting the motor top cover

KPL 500-600

1. Lubricate and fit the O-ring (pos. 157) on the upper bearing bracket (pos. 61c). See fig. 75.
2. Lubricate and fit the O-rings (pos. 157d) on the cable entry (pos. 168).
3. Mount the cable entry (pos. 168) on the motor top cover (pos. 164a), fit the screw (pos. 181a) and tighten it according to section 7. *Tightening torques and lubricants*.
4. Connect the earth cables to the earth connections inside the motor top cover (pos. 164a).
5. Lift the motor top cover (pos. 164a) by the lifting bracket (pos. 190), so that the motor top cover is 15 cm above upper bearing bracket (pos. 61c).
6. Place a correct-size heat shrink tubing on both stator and sensor wires. See fig. 74.
7. Connect the wires correctly, using the wiring diagrams. See section 8. *Electrical connection*.
8. Use a crimping tool (pos. P) and the correct size of wire connectors to connect the wires.
9. When all wires are connected, wrap insulating tape around each wire and place the heat shrink tubing over the cable joint and use a heat gun (pos. F) to shrink the tubing. See fig. 74.
10. Bundle the sensor wires with plastic strips to keep a good order inside the motor top cover.
11. Mount the motor top cover (pos. 164a) and the screws (pos. 178) and tighten them according to section 7. *Tightening torques and lubricants*.

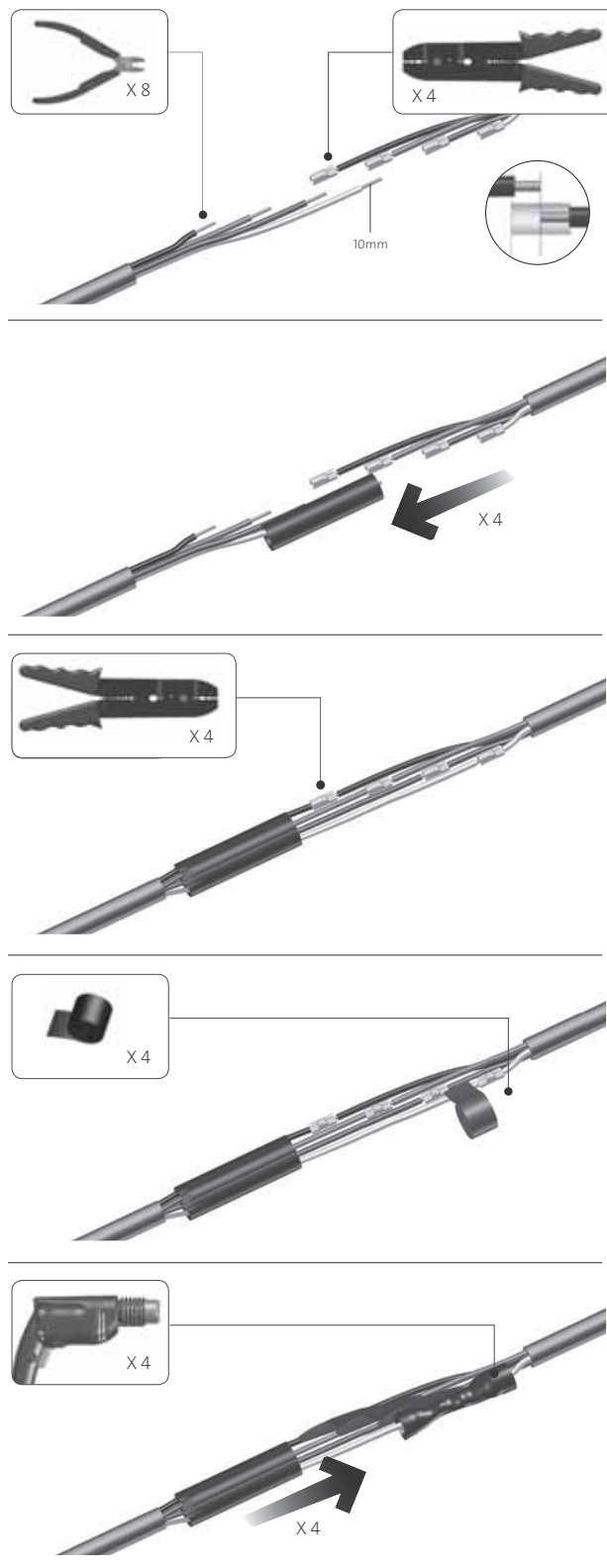

Fig. 74 Joining of wires, KPL 500, 600.

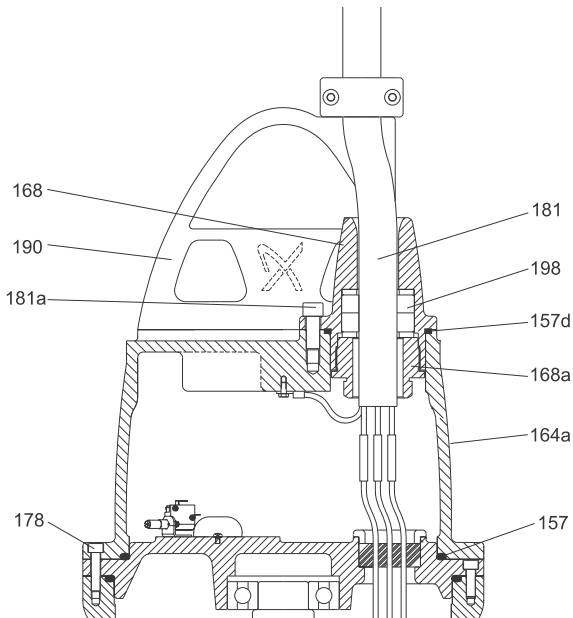

Fig. 75 Top cover details, column 500-600.

KPL 650-800, KWM 600-700

1. Connect the sensor wires to the terminal board (pos. 176a) according to the wiring diagram. See section 8. *Electrical connection*.
2. Connect the stator wires to the terminal board.
3. Lubricate and fit the O-rings (pos. 157d) on the cable entry (pos. 168).
4. Lubricate and fit the O-ring (pos. 157) on the upper bearing bracket (pos. 61c).
5. Mount the motor top cover (pos. 164a) and the screws (pos. 178) and tighten them according to section 7. *Tightening torques and lubricants*.
6. Connect the power cable and sensor cables to the terminal board according to the wiring diagram. See section 8. *Electrical connection*.
7. Connect the earth conductors to the earth connections inside the motor top cover (pos. 164a).
8. Fit the O-ring (pos. 165) to the motor top cover.
9. Mount the terminal box cover (pos. 164), fit the screws (pos. 166) and tighten them according to section 7. *Tightening torques and lubricants*.

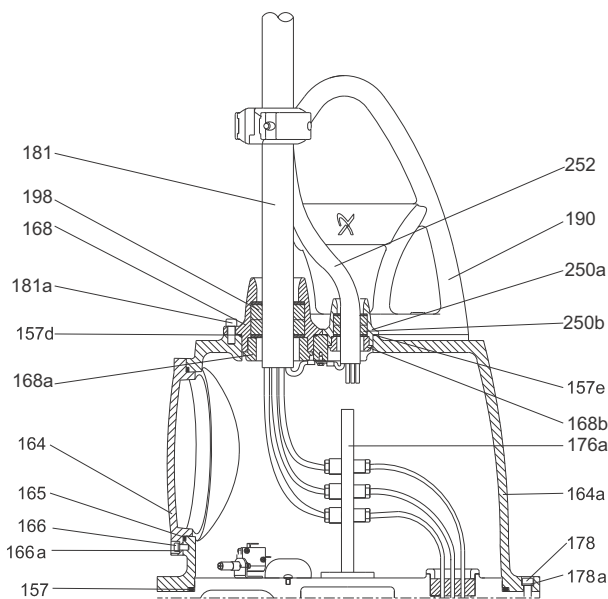

Fig. 76 Top cover details, column 650-1800

13.9 Mounting the cable entry

1. Push the cable through the cable entry.
2. Mount the washer, rubber seal (pos. 198, 250b) and washer on the power cable and the sensor cable.

Caution *The inner diameter of the washer needs to fit with the outer diameter of the cable in order to avoid deformation of the rubber seal (pos. 198).*

3. Mount the cable entry in a vice.
4. Mount the lower cable entry (pos. 168a) and screw it completely home, so the tension on the washer/rubber seals is optimal.

Note *Lubricate the rubber seal well with Rocol Sapphire Aqua-Sil.*

Turbulence optimiser

1. Fit the turbulence optimiser (pos. 117a).
2. Mount the screws (pos. 117b) and tighten them according to section 7. *Tightening torques and lubricants*. See fig. 77.

Discharge casing protector

1. Fit the discharge casing protector (pos. 117c) and mount the screws (pos. 117d) and tighten them according to section 7. *Tightening torques and lubricants*. See fig. 77.

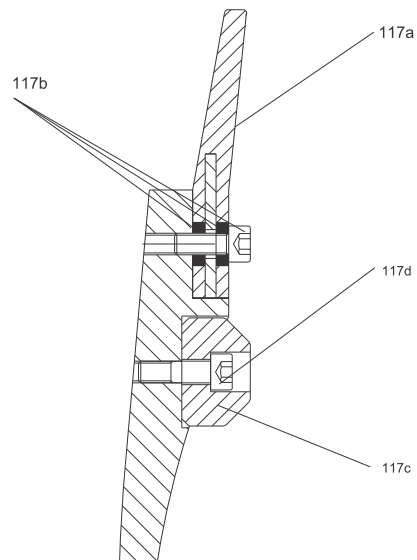

Fig. 77 Turbulence optimiser and discharge casing protector.

TM06 2828 4614

TM06 2303 4614

TM06 2293 4614

14. Dismantling KPL 900-1800, KWM 800-1600

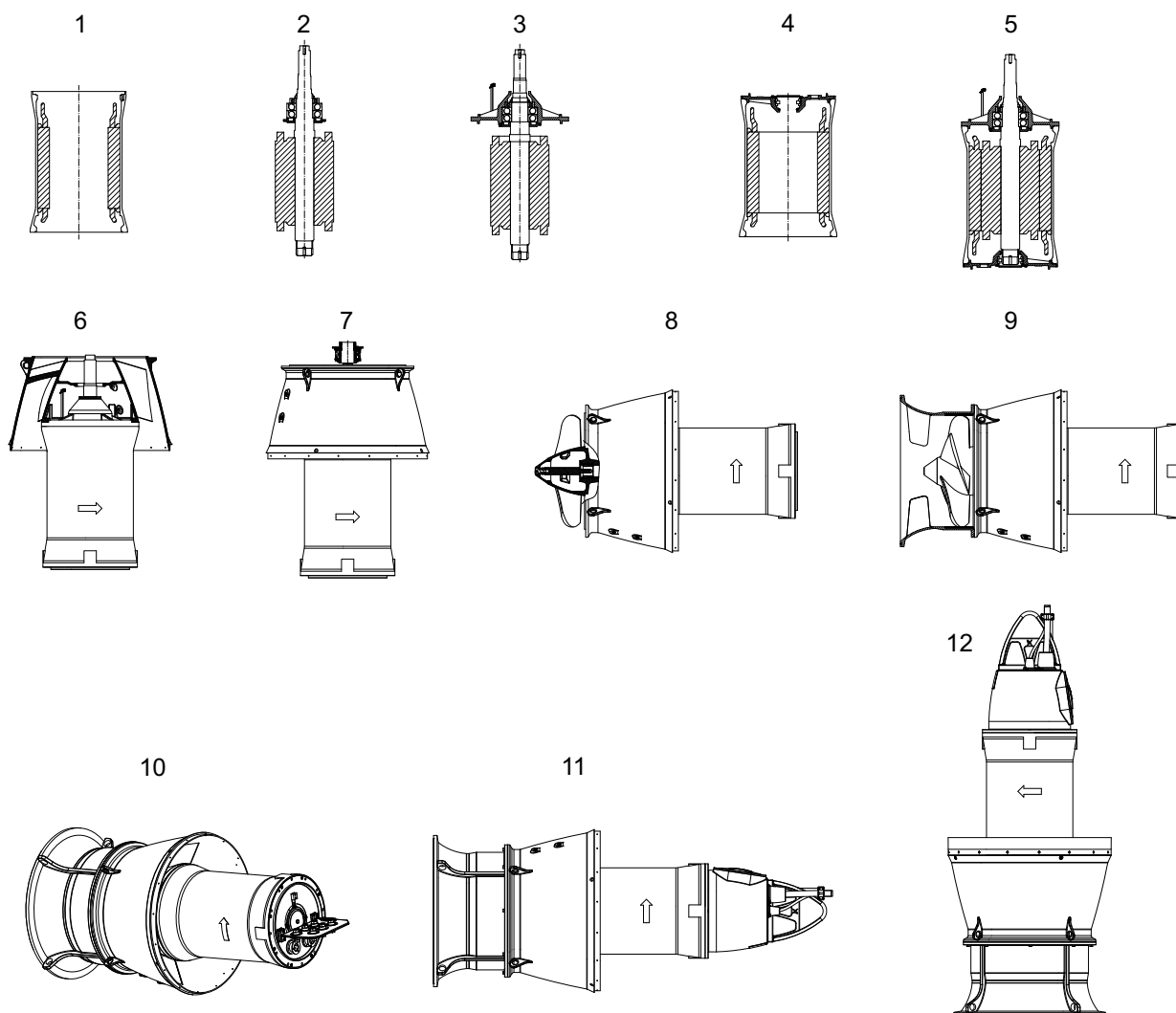

Fig. 78 Assembly order column 900 to 1800

Caution *If service includes oil change or removing the shaft seal, you must remove the oil at the beginning of the service job.*

Position numbers of parts refer to section 20. *Drawings*, 21. *List of materials* and 22. *Exploded views*. Position letters of tools refer to section 6. *Service tools*.

Caution *Make sure the capacity of the lifting equipment is sufficient for lifting the pump. See pump weight on the nameplate of the pump.*

14.1 Removing the cables and the motor top cover

If it is necessary to dismantle the cable entry, skip this part and go to section 14.2 *Removing the power cable/sensor cable*.

KPL 900-1800, KWM 800-1600

1. Loosen and remove the screw (pos. 166).
2. Remove the terminal box cover (pos. 164).
3. Disconnect the power cable and sensor cables from the terminals (pos. 176a).
4. Remove the screw (pos. 178).
5. Disconnect the earth conductors.
6. Lift away the motor top cover (pos. 164a) by the lifting bracket (pos. 190).

14.2 Removing the power cable/sensor cable

KPL 900-1800, KWM 800-1600

1. Loosen and remove the screws (pos.180a). See fig. 79.
2. Remove the cable clamps.

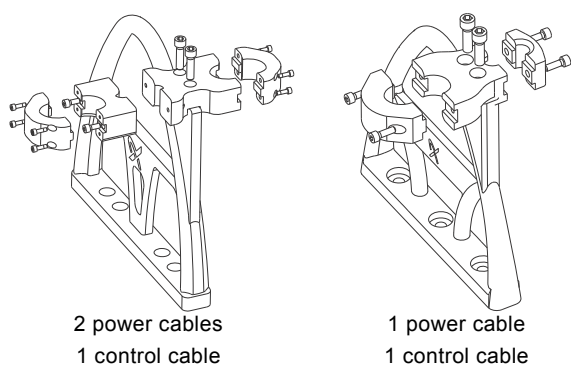

Fig. 79 Cable clamps.

1. Loosen and remove the screw (pos. 166). See fig. 82.
2. Remove the terminal box cover (pos. 164).
3. Disconnect the power cable and the sensor cable from the terminal board (pos. 176a).
4. Loosen and remove the screws (pos. 181a).
5. Remove the cables.

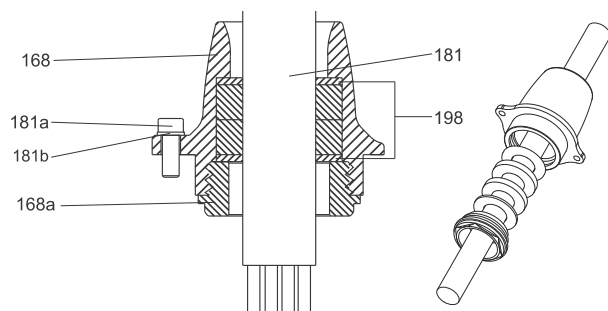

Fig. 80 Cable entry, power cable

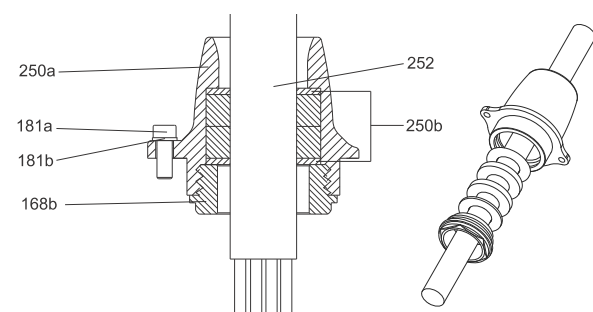

Fig. 81 Cable entry, sensor cable

14.3 Removing the cable entry

KPL 900-1800, KWM 800-1600

Power cable

1. Remove the power cable entry from the motor top cover (pos. 164a).
2. Place the cable entry (pos. 168) in a vice.
3. Unscrew the lower cable entry (pos. 168a).
4. Push the cable and the rubber seal (pos. 198) out of the cable entry (pos. 168).
5. Remove the rubber seal (pos. 198) and washers from the cable. See figs 38 and 39.
6. Pull and remove the cable (pos. 181) from the cable entry.

Sensor cable

1. Remove the sensor cable entry from the motor top cover (pos. 164a).
2. Place the cable entry (pos. 250a) in a vice.
3. Unscrew the lower cable entry (pos. 168b).
4. Push the cable and the rubber seal (pos. 250b) out of cable entry (pos. 250a).
5. Remove the rubber seal (pos. 250b) and washers from the cable.
6. Pull and remove the sensor cable (pos. 252) from the cable entry.

14.4 Removing the motor top cover

KPL 900-1800, KWM 800-1600

1. Remove the cables from the motor top cover.
2. Remove the screw (pos. 178). See fig. 82.
3. Lift away the motor top cover (pos. 164a) by the lifting bracket (pos. 190).
4. Disconnect the motor cable from the terminal board (pos. 176a).
5. Disconnect the moisture switch (pos. 520), the Pt100 bearing temperature sensor (pos. 288), the PVS 3 (pos. 528) sensor wire from SM 113, that is if SM 113 is fitted.
6. Loosen and remove the moisture switch, the Pt100 bearing temperature sensor and the PVS 3 sensor. See fig. 83.
7. Loosen and remove the screws (pos. 176b).
8. Remove the terminal board (pos. 176a).

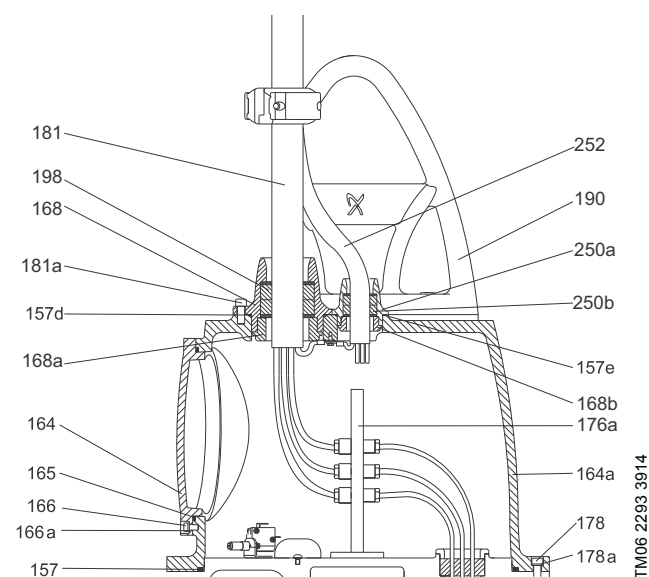
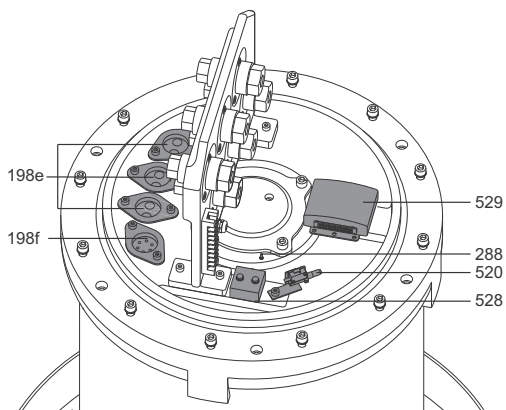
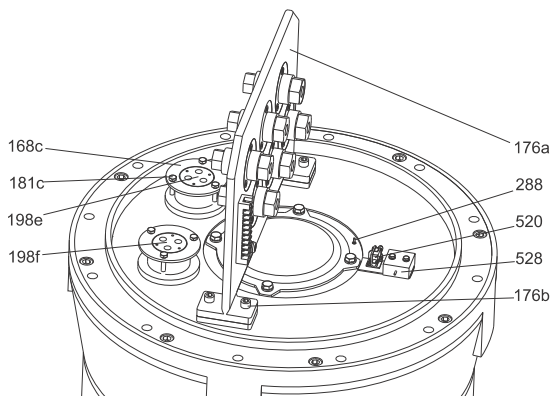

Fig. 82 Top cover details, column 650-1800



TM06 2324 4414



TM06 2829 4614

Fig. 83 Position of sensors, column 650-1800.

14.5 Removing the suction casing

KPL 900-1800, KWM 800-1600

1. Mount shackles in the suction casing (pos. 12a), and mount crane hooks with lifting straps in the shackles.
2. Loosen and remove the screws (pos. 26).
3. Lift away the suction casing with the crane.

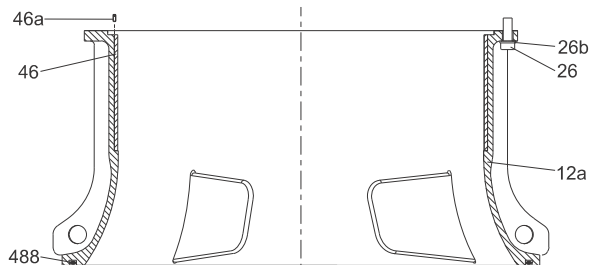

TM06 2315 3914

Fig. 84 Suction casing, KPL

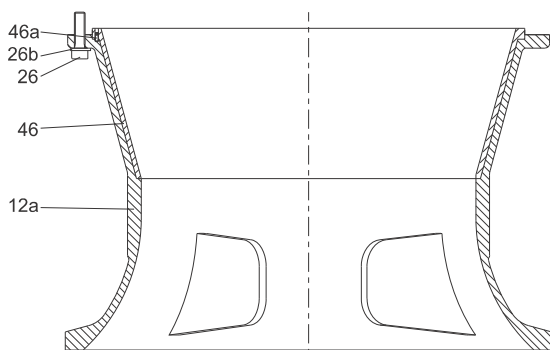

TM06 2316 3914

Fig. 85 Suction casing, KWM, medium head

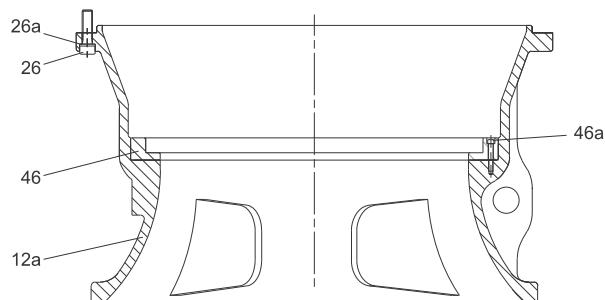

TM06 2502 4414

Fig. 86 Suction casing, KWM, high head

14.6 Removing the wear ring

KPL 900-1800, KWM 800-1600

1. Place the suction casing on two wooden beams with the wear ring facing downwards. Make sure the beams are placed in such way that there is access to all set screws (pos. 46a).
2. Loosen and remove the set screws (pos. 46a).
3. Lift the suction casing, and the wear ring will separate from the suction casing. If not, lift the suction casing slightly over the beams and loosen the wear ring using a hammer.

14.7 Removing the propeller/impeller

KPL 900-1800, KWM 800-1600

1. Loosen and remove the screw (pos. 67a).
2. Remove the cap (pos. 66).
3. **KPL propeller only:** Loosen and remove the support screw (pos. 67) and Power-lock® cover (pos. 66a). See fig. 87.
4. Loosen and remove Power-lock® (pos. 118). See section 11. *Power-lock®*.
5. Lift away the propeller/impeller using lifting straps.

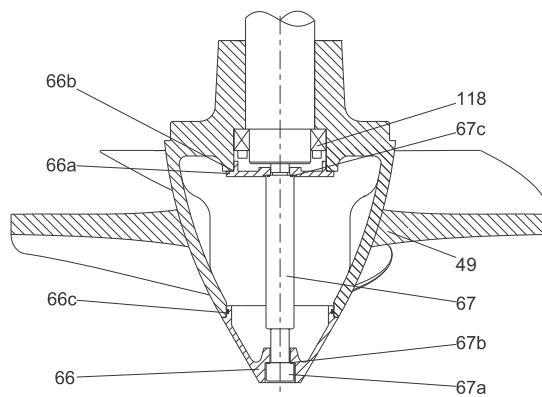

TM06 2313 3914

Fig. 87 Propeller, KPL 700-1800

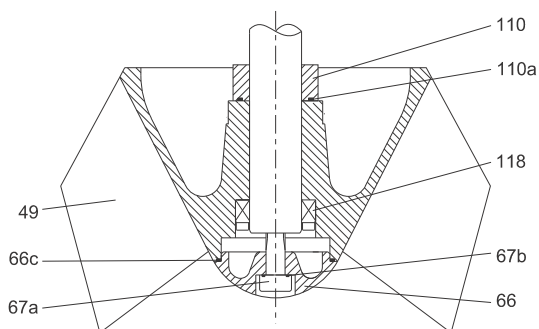

TM06 2312 3914

Fig. 88 Impeller, KWM, medium head

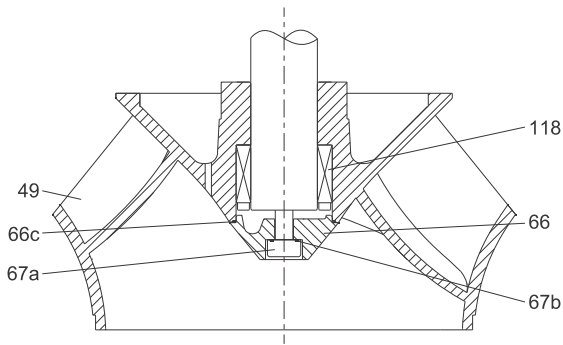

Fig. 89 Impeller, KWM, high head

TM06 2314 3914

14.8 Removing the shaft seal

KPL 900-1800

1. Turn the pump upside down so that the upper bearing bracket is facing down, and place it on two wooden beams.
2. Gently pull and remove the seal ring (pos. 104). See fig. 91.
3. Loosen the screw (pos. 105f) and engage the shaft seal locks (pos. 105e). Then tighten the screw (pos. 105f) again. See fig. 90.

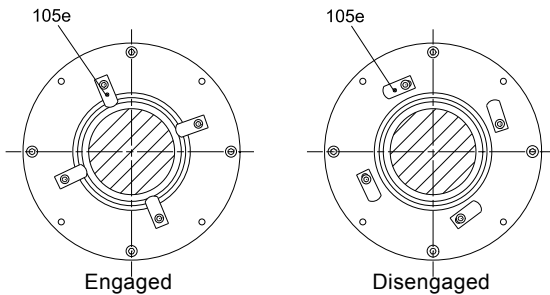

Fig. 90 Shaft seal locks

TM06 2501 4414

4. Loosen the set screws (pos. 104b).
5. Loosen and remove the screws (pos. 105d).
6. Mount the screws (pos. 105d) in the dismantling threads placed next to the normal position of the screws (pos. 105d). See fig. 90. Tighten the screws equally until shaft seal is loose.
7. Remove the shaft seal (pos. 105).

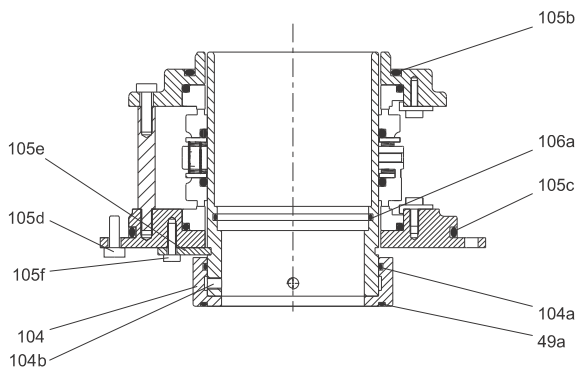

Fig. 91 Shaft seal, column 600-1800

TM06 2309 3914

KWM 800-1600

1. Turn the pump upside down so that the upper bearing bracket is facing down, and place it on two wooden beams.
2. Loosen the screw (pos. 26a) and remove the water chamber (pos. 77).
3. Pull off intermediate ring (pos. 110).
4. Gently pull and remove the seal ring (pos. 104).
5. Loosen the screw (pos. 105f) and engage the shaft seal locks (pos. 105e). Then tighten the screw (pos. 105f) again. See fig. 90.
6. Loosen the set screws (pos. 104b). See fig. 91.
7. Loosen and remove the screws (pos. 105d).
8. Mount the screws (pos. 105d) in the dismantling threads placed next to the normal position of the screws (pos. 105d) and tighten the screws equally until the shaft seal is loose.
9. Remove the shaft seal (pos. 105) by pulling it off the shaft.

14.9 Removing the discharge casing

If the turbulence optimiser or/and the discharge casing protectors are worn down or defect, we recommend to replace them. See fig. 92 for a more detailed view.

Turbulence optimiser

1. Loosen and remove the screw (pos. 117b).
2. Lift away the turbulence optimiser (pos. 117a). See fig. 92.

Discharge casing protector

1. Loosen and remove the screw (pos. 117d).
2. Remove the discharge casing protector (pos. 117c). See fig. 92.

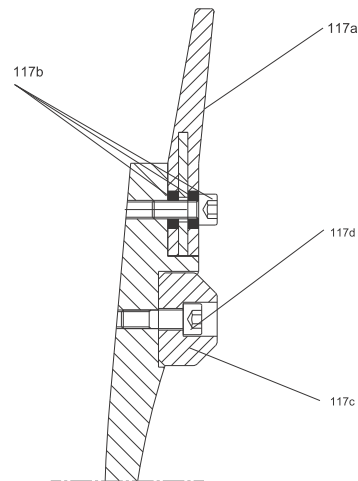

Fig. 92 Turbulence optimiser and discharge casing protector

TM06 2304 4614

KPL 900-1800, KWM 800-1600

1. Mount two shackles with lifting straps in the anti-rotation brackets/lifting brackets and connect them to a crane hook.
2. Loosen and remove the screws (pos. 184a).
3. Lift away the discharge casing (pos. 117).

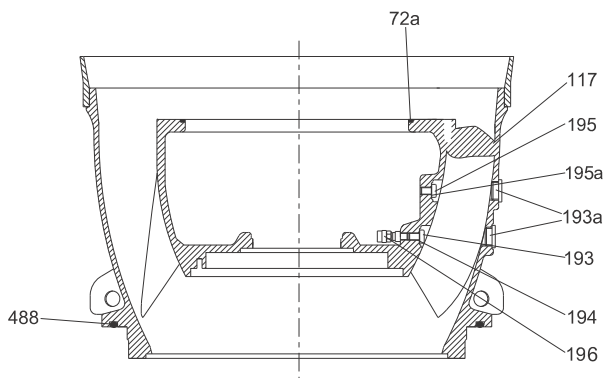

Fig. 93 Discharge casing, KWM

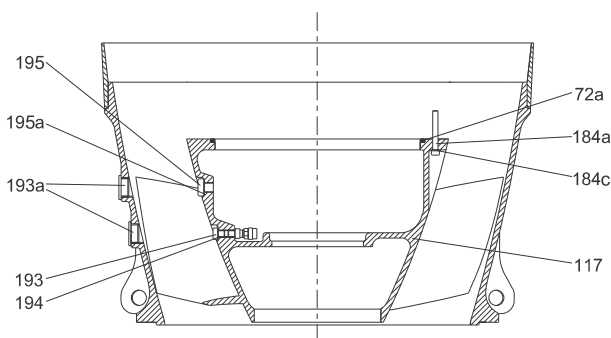

Fig. 94 Discharge casing, KPL

14.10 Removing the rotor with bearings

KPL 900-1800, KWM 800-1600

1. Mount an eyebolt in the drive end of the shaft and place a crane hook in the eyebolt.
2. Loosen and remove the screw (pos. 184).
3. Gently lift the rotor up 10-15 cm, so as to get access to the cables and the moisture switch (pos. 521).
4. Disconnect the following sensor wires:
 - moisture switch
 - bearing temperature sensor
 - WIO sensor with transient protector, if fitted.
5. Lift away the rotor with bearing bracket.

14.11 Removing the lower bearings

KPL 900-1800, KWM 800-1600

1. Place the rotor with bearing cover in vertical position on a suitable, stable workbench.
2. Loosen the cable gland (pos. 523a) from both sides of the lower bearing bracket (pos. 155). See fig. 95.
3. Disconnect the WIO sensor from the transient protector, cut off the spade connectors of the water-in-oil sensor (pos. 523) and pull out the cable through the cable glands.
4. Loosen and remove the screw for the WIO sensor bracket (pos. 522d) and remove the WIO sensor with bracket.
5. Loosen and remove the screws (pos. 521b) for the moisture switch (pos. 521).
6. Mount three eyebolts on the lower bearing bracket (pos. 155), placed at 120 ° angles.
7. Fit straps into the eyebolts and place a crane hook in all three straps
8. Loosen and remove the screws (pos. 182b) for the bearing cover (pos. 60).
9. Gently lift the lower bearing bracket (pos. 155) free of the bearings and the shaft.
10. Unlock the lock washer (pos. 271), loosen and remove the bearing lock nut (pos. 270).
11. Remove the bearings (pos. 153, 153a) using a press, and by pressing on the inner ring of the bearings.
12. Remove the bearing bracket cover (pos. 60) of the lower bearing bracket from the shaft.

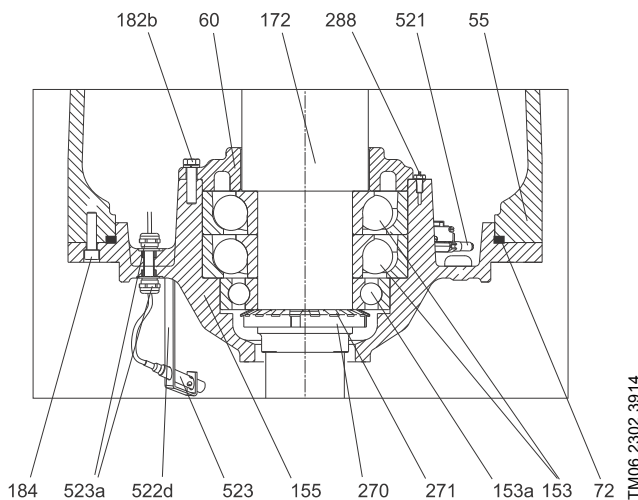

Fig. 95 Lower bearing bracket, column 900-1800

14.12 Removing the upper bearing and the bearing bracket

KPL900-1800, KWM 800-1600

Note The upper bearing is a "separable bearing" type, meaning that the inner and outer rings can be removed individually.

When you lift the rotor from the stator housing, the inner ring of the upper bearing will follow the shaft, and the outer ring with cage and rollers will stay in the upper bearing bracket (pos. 61c).

1. Remove the inner ring of the upper bearing (pos. 154) mounted on the shaft (pos. 172), using a puller.
2. Remove the seal sleeve (pos. 154d) from the shaft (pos. 172), using a puller.
3. Loosen and remove the screw (pos. 182b) and remove the upper bearing cover (pos. 62).
4. Remove the upper bearing bracket (pos. 61c) from the stator housing (pos. 55).
5. Knock out the seal ring (pos. 154b) from the upper bearing bracket, using a punch.
6. Remove the outer ring of the bearing (pos. 154), using a puller.

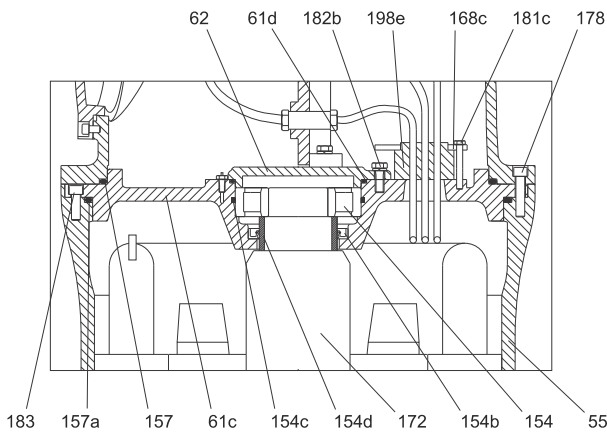

Fig. 96 Sectional view of the upper bearing bracket

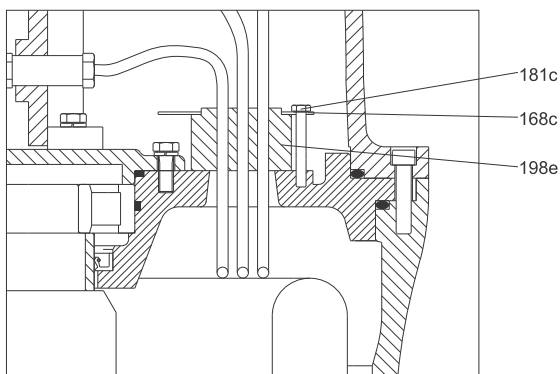

Fig. 97 Cable bushing on the upper bearing bracket

15. Assembling KPL 900-1800, KWM 800-1600

Before assembling

- Clean and check all parts.
- Replace defective parts with new parts.
- Order the necessary service kits.
- Always replace gaskets and O-rings.

During assembling

- Lubricate and tighten screws, nuts and O-rings according to section 7. *Tightening torques and lubricants*.

15.1 Mounting the bearings and the lower bearing bracket

KPL 900-1800, KWM 800-1600

7. Place the lower bearing bracket cover (pos. 60) on the shaft.
8. Heat up the bearings (pos. 153, 153a) to 120 °C one at a time and mount them on the shaft, let the shaft and bearing cool down between each mounting.
9. Fit the lock washer (pos. 271) on the shaft.
10. Fit the lock nut (pos. 270) on the shaft and tighten the nut.
11. Heat up the bearing bracket (pos. 155) to 150 °C and press the shaft with bearings into the bracket.
12. Fit the screws (pos. 182b) in the lower bearing cover (pos. 60) and tighten them according to section 7. *Tightening torques and lubricants*.
13. Mount the moisture switch (pos. 521).
14. Mount the WIO sensor bracket (pos. 522d) and WIO sensor (pos. 523).

Note Make sure the WIO sensor is placed correctly in relation to the direction of rotation. See fig. 98.

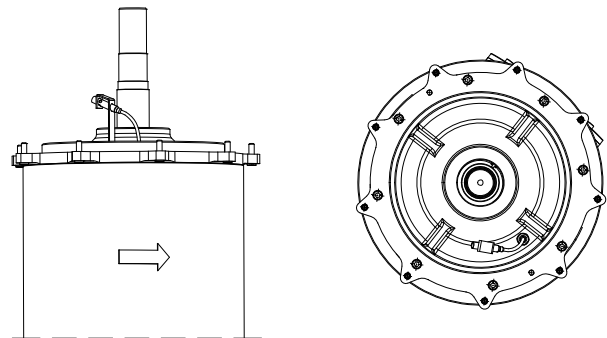

Fig. 98 Correct position of WIO sensor

15. Mount the cable gland (pos. 523a) and take the WIO sensor cable through the cable gland, making sure that the cable length on the sensor side is correct. It must not interfere with the shaft seal.
16. Tighten the cable gland (pos. 523a).
17. Prepare the sensor wires with connectors, according to the sensor wiring diagrams. See 8. *Electrical connection*.

15.2 Mounting the upper bearing bracket

1. Place the stator housing (pos. 55) on two wooden beams.
2. Press the seal sleeve (pos. 154b) into place in the upper bearing bracket (pos. 61c). See fig. 99.
3. Lubricate and fit the O-ring (pos. 154c) in the bearing bush.
4. Press the outer ring of the upper bearing (pos. 154) into place in the upper bearing bracket (pos. 61c).

Note *Make sure that the O-ring (pos. 154c) is not pinched while mounting the outer bearing ring.*

5. Lubricate and fit the O-ring (pos. 61d) on the upper bearing cover (pos. 62).
6. Fit the upper bearing cover (pos. 62).
7. Fit the screws (pos. 182b) and tighten them according to section 7. *Tightening torques and lubricants*.
8. Lubricate and fit the O-ring (pos. 157a) to the upper bearing bracket (pos. 61c).

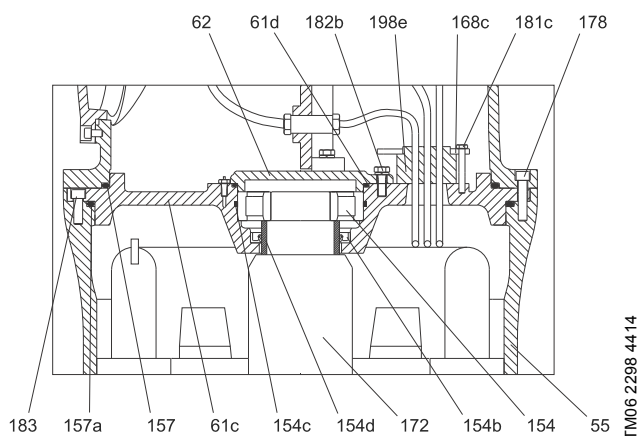

Fig. 99 Upper bearing, KPL 900-1800, KWM 800-1600

9. Take the correct number of wires through each cable bushing (pos. 198e, 198f, 199), so it fits the correct cable gland.
10. Mount the bearing bracket (pos. 61c) on the stator housing (pos. 55) and tighten the screws (pos. 183).
11. Fit the correct cable glands (pos. 198e) and cable entries (pos. 168c). See fig. 97.
12. Fit the screws (pos. 181c) and tighten them according to section 7. *Tightening torques and lubricants*.
13. Turn the stator housing (pos. 55) with upper bearing bracket (pos. 61c) upside down.

15.3 Mounting the shaft into the stator

1. Lift the shaft (pos. 172) with bearing bracket (pos. 155) above the stator housing (pos. 55).
2. Lower the shaft (pos. 172) with lower bearing bracket (pos. 155) until there is a gap of 15-20 cm between stator housing (pos. 55) and the lower bearing bracket (pos. 155).
3. Connect the sensor wires according to the wiring diagrams. See 8. *Electrical connection*.
4. Lower the shaft into place in the stator housing, making sure the upper bearing is centred in relation to the upper bearing bracket while lowering it into place.
5. Mount the screws (pos. 184) and tighten them according to section 7. *Tightening torques and lubricants*.

Caution *Do not pinch the sensor wires while lowering down the shaft.*

15.4 Mounting the discharge casing

1. Lubricate and fit the O-ring (pos. 72a) on the lower bearing bracket (pos. 155).
2. Mount the non-return valve (pos. 196) in the discharge casing.
3. Lower the discharge casing (pos. 117) into place.
4. Mount the screws (pos. 184a) and tighten them according to section 7. *Tightening torques and lubricants*. See figs 100 and 101.
5. KWM 800-1600 only: Lubricate and mount the O-ring (pos. 488) on the discharge casing (pos. 117). See fig. 100.

Note *The turbulence optimiser and the discharge casing protector will be mounted at the end of the assembling procedure.*

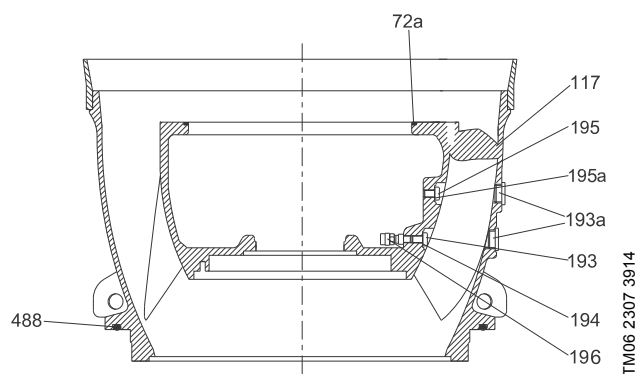

Fig. 100 Discharge casing, KWM

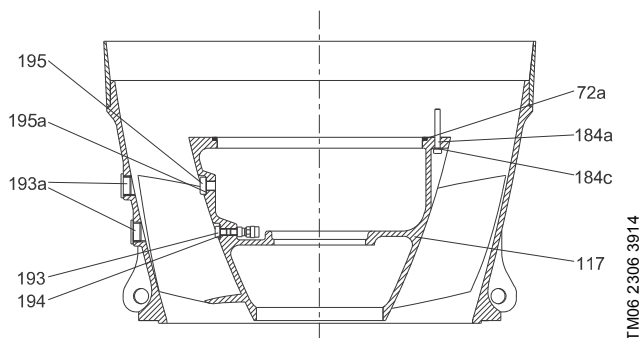

Fig. 101 Discharge casing, KPL

15.5 Mounting the shaft seal

1. Make sure the shaft seal locks (pos. 105e) are engaged. See fig. 103.
2. Lubricate and fit the O-rings (pos. 105b, 105c and 106a).
3. Push the shaft seal (pos. 105) into place on the shaft.
4. Mount the screws (pos. 105d) and tighten them according to section 7. *Tightening torques and lubricants*.
5. Tighten the screws (pos. 104b) according to section 7. *Tightening torques and lubricants* so that the shaft seal liner is engaged with the shaft.
6. Disengage the shaft seal locks (pos. 105e) and retighten the screw (pos. 105f). See fig. 103.
7. Lubricate and fit the O-rings (pos. 104a and 49a) in the seal ring (pos. 104).
8. Fit the seal ring (pos. 104).

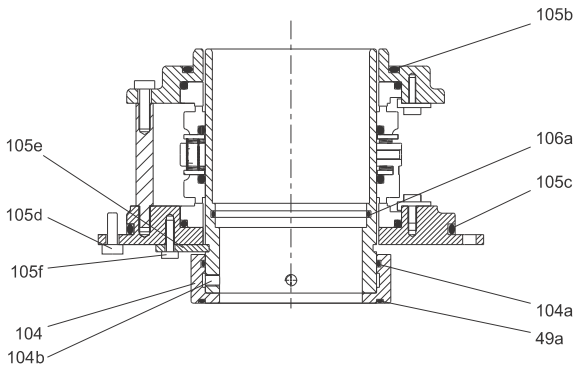

Fig. 102 Shaft seal, column 600-1800

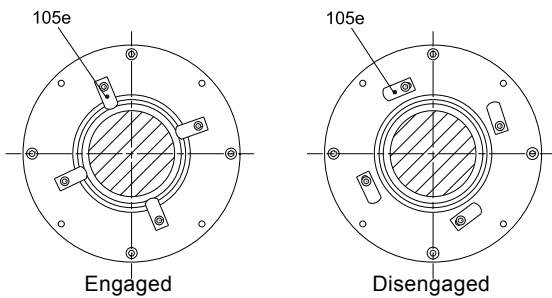

Fig. 103 Shaft seal locks

15.6 Mounting the propeller/impeller

Place the pump in a horizontal position. See fig. 78, drawing 8.

KPL 900-1800

1. Fit the propeller (pos. 49).
2. Fit Power-lock®. See section 11. *Power-lock®*.
3. Force the propeller into position using a rectangular piece of metal in order to make sure that the impeller is mounted correctly. See fig. 104.

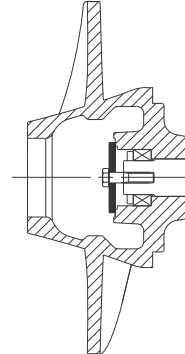

Fig. 104 Mount of propeller/impeller

4. Tighten Power-lock® according to section 11. *Power-lock®*.
5. Lubricate and fit the O-ring (pos. 66b) on the Power-lock® cover (pos. 66a). See fig. 105.
6. Lubricate and fit the O-ring (pos. 67c) on the support screw (pos. 67).
7. Mount Power-lock® cover (pos. 66a) and fit the support screw (pos. 67) and tighten it according to section 7. *Tightening torques and lubricants*.
8. Mount the propeller cap (pos. 66), the O-ring (pos. 66c), the screw (pos. 67a), the O-ring (pos. 67b) and tighten the screw according to section 7. *Tightening torques and lubricants*.

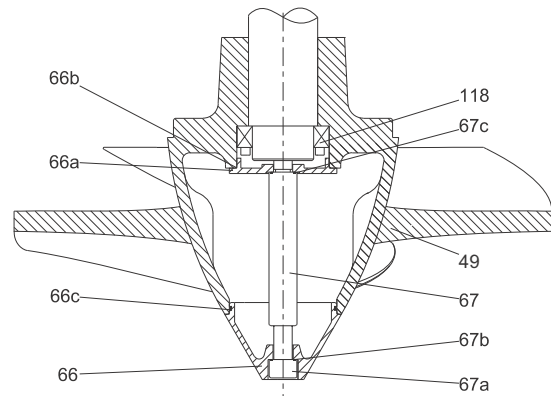

Fig. 105 Propeller, KPL 700-1800

TM06 2505 4414

TM06 2309 3914

TM06 2501 4414

TM06 2313 3914

KWM 800-1600

1. Mount the water chamber (pos. 77) and fit the screws (pos. 26a) and tighten them according to section 7. *Tightening torques and lubricants*.
2. Mount the intermediate ring (pos. 110) and the O-ring (pos. 110a).
3. Fit the impeller (pos. 49).
4. Fit Power-lock®.
5. Force the impeller into position using a rectangular piece of metal in order to make sure that the impeller is mounted correctly. See fig. 104.
6. Tighten Power-lock® according to section 11. *Power-lock®*.
7. Lubricate and fit the O-ring (pos. 66c) on the impeller cap (pos. 66). See figs 106 and 107.
8. Lubricate and fit the O-ring (pos. 67b) on the screw (pos. 67a).
9. Mount the impeller cap (pos. 66), fit the screw (pos. 67a) and tighten it according to section 7. *Tightening torques and lubricants*.

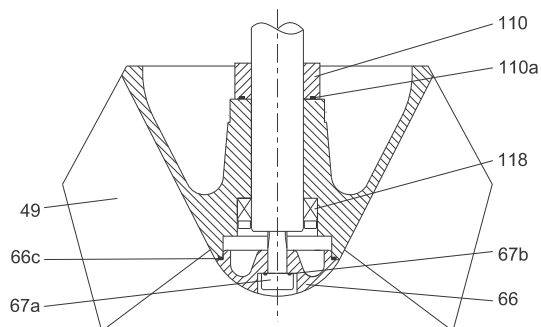
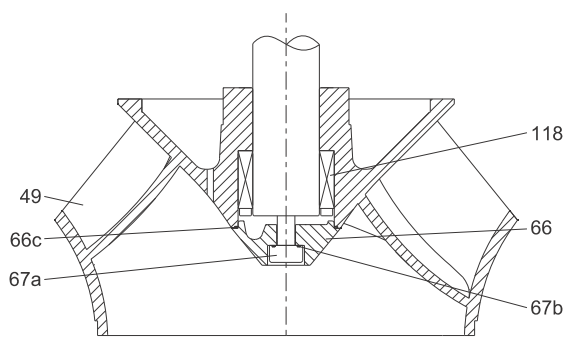
**Fig. 106** Impeller, KWM, medium head**Fig. 107** Impeller, KWM, high head**15.7 Mounting the suction casing and the wear ring**

1. Place the suction casing (pos. 12a) on two wooden beams.
2. Lower down and fit the wear ring (pos. 46) into place. See figs 108-110.

Note Tap new threaded holes for the set screws (pos. 46a).

3. Tap new holes, mount the set screws (pos. 46a) and tighten them according to section 7. *Tightening torques and lubricants*.
4. Mount the suction casing (pos. 12a) on the discharge casing (pos. 117).
5. Fit the screws (pos. 26) and tighten them according to section 7. *Tightening torques and lubricants*.
6. **Only KPL:** Lubricate and fit the O-ring (pos. 488) on the suction casing (pos. 12a).

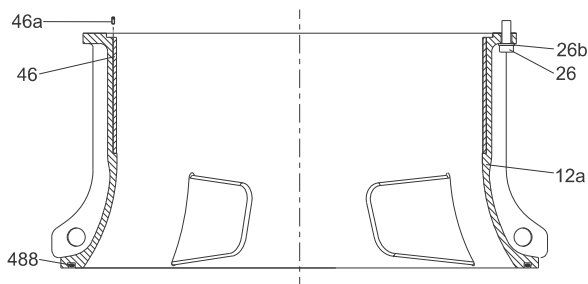
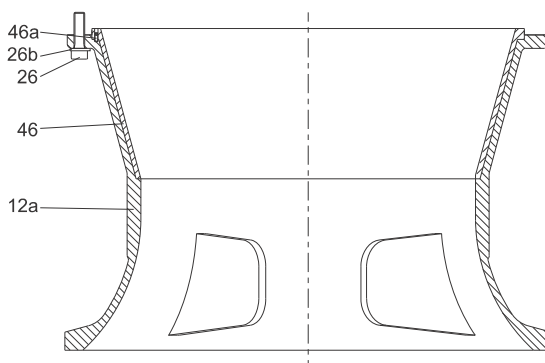
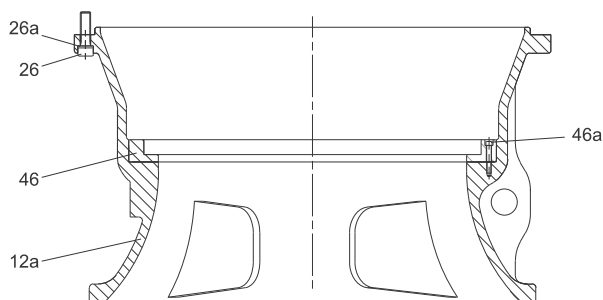
**Fig. 108** Suction casing, KPL**Fig. 109** Suction casing, KWM, medium head**Fig. 110** Suction casing, KWM, high head

TM06 2315 3914

TM06 2316 3914

TM06 2502 4414

15.8 Mounting the sensors

1. Mount the sensors according to fig. 111.
2. Mount the terminal board (pos. 176a), fit the screws (pos. 176b) and tighten them according to section 7. *Tightening torques and lubricants*.

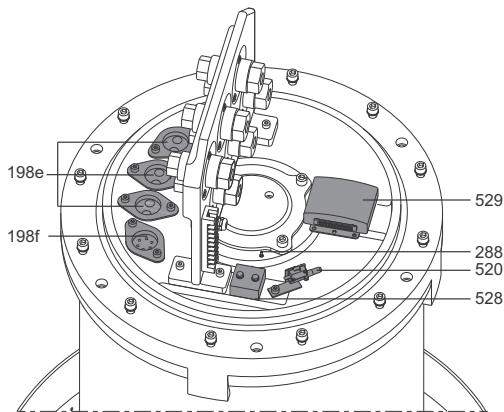

TM06 2324 4414

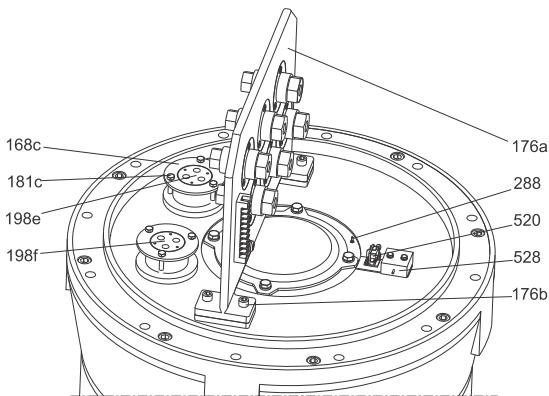

TM06 2829 4614

Fig. 111 Position of sensors, column 650-1800

15.9 Mounting the motor top cover

1. Connect the sensor wires to the terminal board (pos. 176a) according to the wiring diagram. See section 8. *Electrical connection*.
2. Connect the stator wires to the terminal board.
3. Lubricate and fit the O-ring (pos. 157) on the upper bearing bracket (pos. 61c).
4. Mount the motor top cover (pos. 164a) and the screws (pos. 178) and tighten them according to section 7. *Tightening torques and lubricants*.
5. Lubricate and fit the O-rings (pos. 157d) on the cable entries (pos. 168).
6. Connect the power cables and sensor wires to the terminal board according to the wiring diagram. See section 8. *Electrical connection*.
7. Fit the O-ring (pos. 165) to the motor top cover.
8. Mount the terminal box cover (pos. 164), fit the screws (pos. 166) and tighten them according to section 7. *Tightening torques and lubricants*.

Turbulence optimiser

1. Fit the turbulence optimiser (pos. 117a).
2. Mount the screws (pos. 117b) and tighten them according to section 7. *Tightening torques and lubricants*. See fig. 112.

Discharge casing protector

1. Fit the discharge casing protector (pos. 117c) and mount the screws (pos. 117d) and tighten them according to section 7. *Tightening torques and lubricants*. See fig. 112.

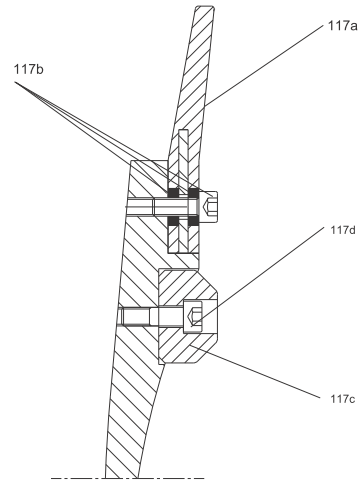

TM06 2304 3914

Fig. 112 Turbulence optimiser and discharge casing protector

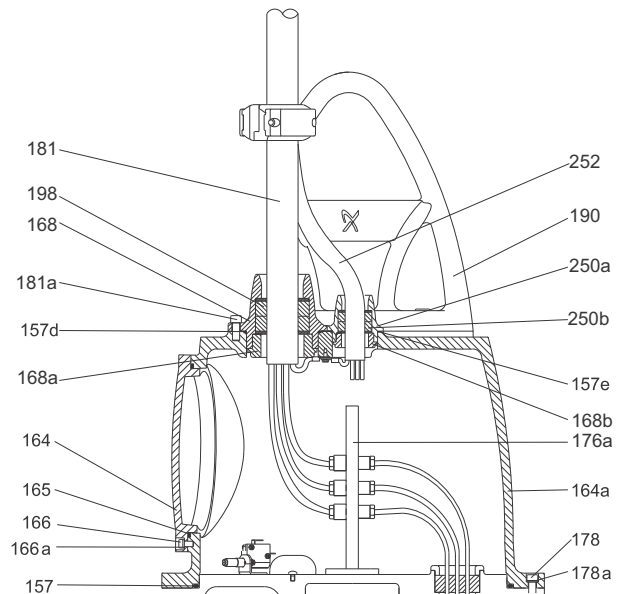

TM06 2293 3914

Fig. 113 Top cover details, column 650-1800

15.10 Mounting the cable entry

1. Push the cable through the cable entry.
2. Mount the washer/rubber seal/washer (pos. 198) on the cable.

Caution

The inner diameter of the washer needs to fit with the outer diameter of the cable in order to avoid deformation of the rubber seal (pos. 198).

3. Mount the cable entry in a vice.

Note

Lubricate the rubber seal well with Rocol Sapphire Aqua-Sil.

4. Mount the lower cable entry (pos. 168a) and screw it completely home, so the tension on the washer/rubber seals is optimal.

16. Starting-up the pump

Warning



Before starting work on the pump, make sure that the fuses have been removed or the mains switch has been switched off. Make sure that the power supply cannot be accidentally switched on.

Make sure that all protective equipment has been connected correctly.

The pump must not run dry.



Warning

The pump must not be started if the atmosphere in the pit is potentially explosive.



Warning

It may lead to personal injuries or death to open the clamp while the pump is operating.

16.1 General startup procedure

This procedure applies to pumps in new installations as well as to pumps being started up after service inspections, if startup takes place some time after the pump was placed in the pit.

1. Remove the fuses and check that the propeller/impeller can rotate freely. Turn the propeller/impeller by hand.



Warning

The propeller/impeller can have sharp edges - wear protective gloves.

2. Check the condition of the oil in the oil chamber. See also section [10.5 Oil check and oil change](#).
3. Check that the system, screws, gaskets, pipework and valves etc. are in correct condition.
4. Mount the pump in the system.
5. Switch on the power supply.
6. Check whether the monitoring units, if used, are operating satisfactorily.
7. **Pump with sensor:** Switch on the IO 113 and check that there are no alarms or warnings.
8. Check the setting of air bells, float switches or electrodes.
9. Check the direction of rotation. See section [16.2 Direction of rotation](#).
10. Open the isolating valves, if fitted.
11. Check that the liquid level is above the motor for S1 operation and above the cable entry for S3 operation. If the liquid is not at the minimum level, do not start the pump.
12. Start the pump and let it run briefly, and check if the liquid level is being lowered.
13. Observe if the discharge pressure and input current are normal. If not there might be air trapped inside the pump.

Note

Trapped air can be removed from the pump housing by tilting the pump by means of the lifting chain when the pump is in operation.

Caution

In case of abnormal noise or vibrations from the pump, other pump failure, power supply failure or water supply failure, stop the pump immediately. Do not attempt to restart the pump until the cause of the fault has been found and the fault corrected.

After one week of operation or after replacement of the shaft seal, check the condition of the oil in the oil chamber. For pumps without sensor, this is done by taking a sample of the oil.

Every time the pump has been removed from the pit, go through the above procedure when starting up again.

16.2 Direction of rotation

Note

The pump may be started for a very short period without being submerged to check the direction of rotation.



Warning

For Ex pumps, the check must be carried out outside the Ex area.

Check the direction of rotation before starting up the pump.

An arrow on the stator housing shows the correct direction of rotation. Correct direction of rotation is clockwise when viewed from above.

16.2.1 Checking the direction of direction

Check the direction of rotation in the following way every time the pump is connected to a new installation.

1. Let the pump hang from a lifting device, e.g. the crane used for lowering the pump into the well.
2. Start and stop the pump while observing the movement (jerk) of the pump. If connected correctly, the pump will rotate clockwise, i.e. it will jerk counter-clockwise. See fig. [114](#).
3. If the direction of rotation is wrong, interchange any two of the phases in the power cable.

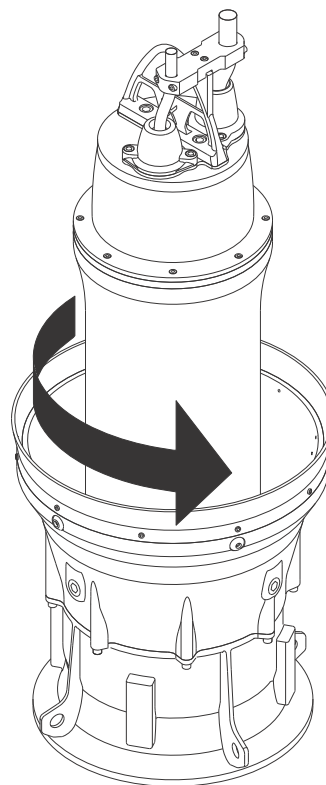

Fig. 114 Jerk direction

17. Fault finding



Warning

Before attempting to diagnose any fault, make sure that the fuses have been removed or the mains switch has been switched off.

Make sure that the power supply cannot be accidentally switched on.
All rotating parts must have stopped moving.



Warning

Observe all regulations applying to pumps installed in potentially explosive environments.
Make sure that no work is carried out in potentially explosive atmosphere.

Note

For pumps with sensor, start fault finding by checking the status on the IO 113 front panel.
See installation and operating instructions for the IO 113.

Fault	Cause	Remedy
1. Motor does not start. Fuses blow, or motor-protective circuit breaker trips out immediately. Caution: Do not start again!	a) Supply failure, short circuit, earth-leakage fault in cable or motor winding.	Have the cable and motor checked and repaired by a qualified electrician.
	b) Fuses blow due to use of wrong type of fuse.	Fit fuses of the correct type.
	c) Propeller/impeller blocked by impurities.	Clean the propeller/impeller.
	d) Air bells, float switches or electrodes out of adjustment or defective.	Readjust or replace the air bells, float switches or electrodes.
	e) Moisture in the stator housing (alarm). The IO 113 interrupts the power supply. *	Replace the O-rings, the shaft seal and moisture switch.
	f) The water-in-oil sensor is not covered by oil (alarm). The IO 113 interrupts the power supply. *	Check, and possibly replace, the shaft seal, fill up with oil, and reset the IO 113.
	g) Stator insulation resistance too low. *	Reset alarm on the IO 113. See installation and operating instructions for the IO 113.
2. Pump operates, but motor-protective circuit breaker trips out after a short while.	a) Too low setting of thermal relay in motor-protective circuit breaker.	Set the relay in accordance with the specifications on the pump nameplate.
	b) Increased current consumption due to large voltage drop.	Measure the voltage between two motor phases. Tolerance: - 10 %/+ 10 %. Re-establish correct power supply.
	c) Impeller blocked by impurities. Increased current consumption in all three phases.	Clean the impeller.
	d) Wrong direction of rotation.	Check the direction of rotation and possibly interchange any two of the incoming supply wires. See section 16.2 Direction of rotation .
3. The thermal switch of the pump trips out after a short while.	a) Too high liquid temperature.	Re-establish adequate cooling.
	b) Too high viscosity of the pumped liquid.	Dilute the pumped liquid.
	c) Fault in the electrical connection. Changeover from Y-connection to D-connection results in considerable under-voltage.	Check and correct the electrical installation.
4. Pump operates at below standard performance and power consumption.	a) Propeller/impeller blocked by impurities.	Clean the propeller/impeller.
	b) Wrong direction of rotation.	Check the direction of rotation and possibly interchange any two of the incoming supply wires. See section 16.2 Direction of rotation .
5. Pump operates, but gives no liquid.	a) Discharge valve closed or blocked.	Check the discharge valve, and open or clean it.
	b) Non-return valve blocked.	Clean the non-return valve.
	c) Air in the pump.	Vent the pump.
6. High power consumption.	a) Wrong direction of rotation.	Check the direction of rotation and possibly interchange any two of the incoming supply wires. See section 16.2 Direction of rotation .
	b) Propeller/impeller blocked by impurities.	Clean the propeller/impeller.
7. Noisy operation and excessive vibrations.	a) Wrong direction of rotation.	Check the direction of rotation, and possibly interchange any two of the incoming supply wires. See section 16.2 Direction of rotation .
	a) Propeller/impeller blocked by impurities.	Clean the propeller/impeller.
8. Pump clogged.	a) The liquid contains large particles.	Select a pump with a larger size of passage.
	b) A float layer has formed on the surface of the liquid.	Install a mixer in the well.

* Applies only to pumps with sensor and with IO 113.

18. Power-lock®

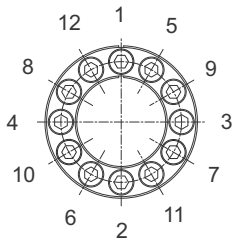

M06.DR200-30x55

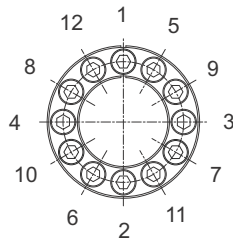

M06.DR200-35x60

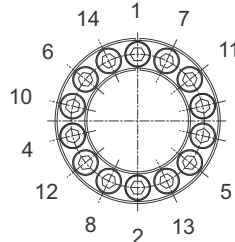

M06.DR200-40x65

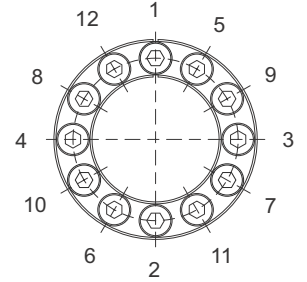

M08.DR200-50x80

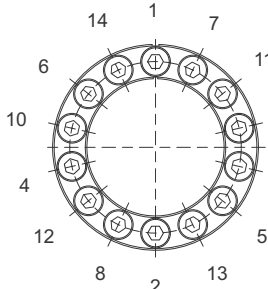

M08.DR200-60x90

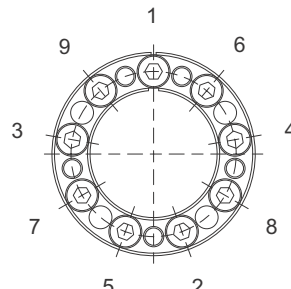

M08.DR400-50x80

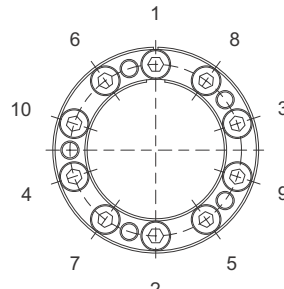

M08.DR400-60x90

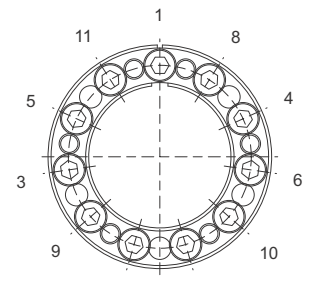

M10.DR400-70x110

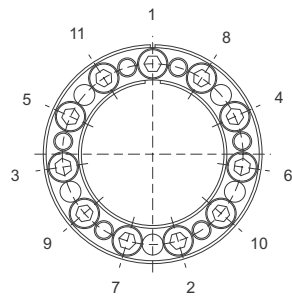

M10.DR400-75x115

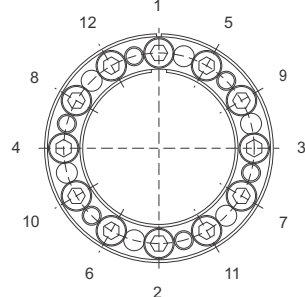

M10.DR400-80x120

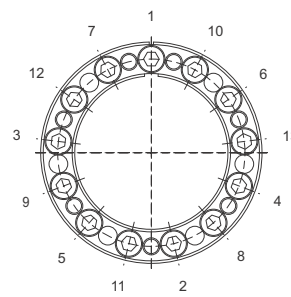

M10.DR400-90x130

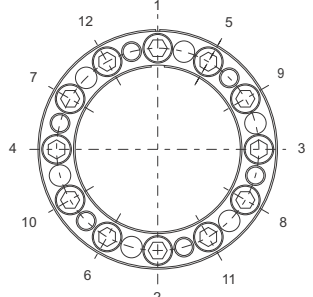

M12.DR400-100x145

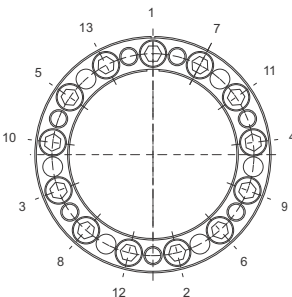

M12.DR400-110x155

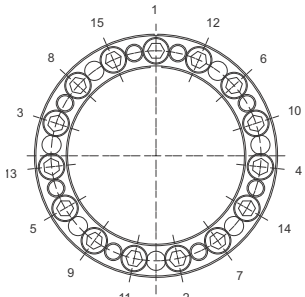

M12.DR400-120x165

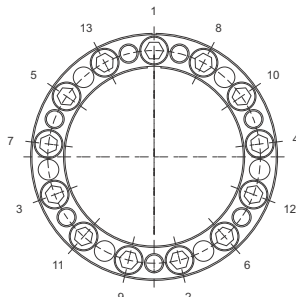

M14.DR400-130x180

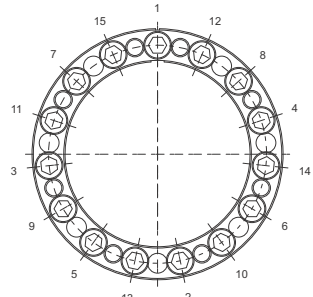

M14.DR400-140x190

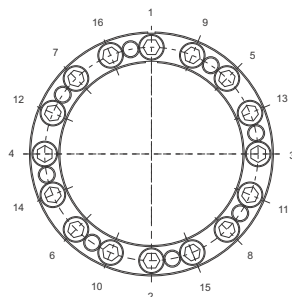

M14.DR400-150x200

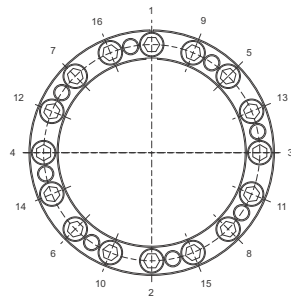

M14.DR400-160x210

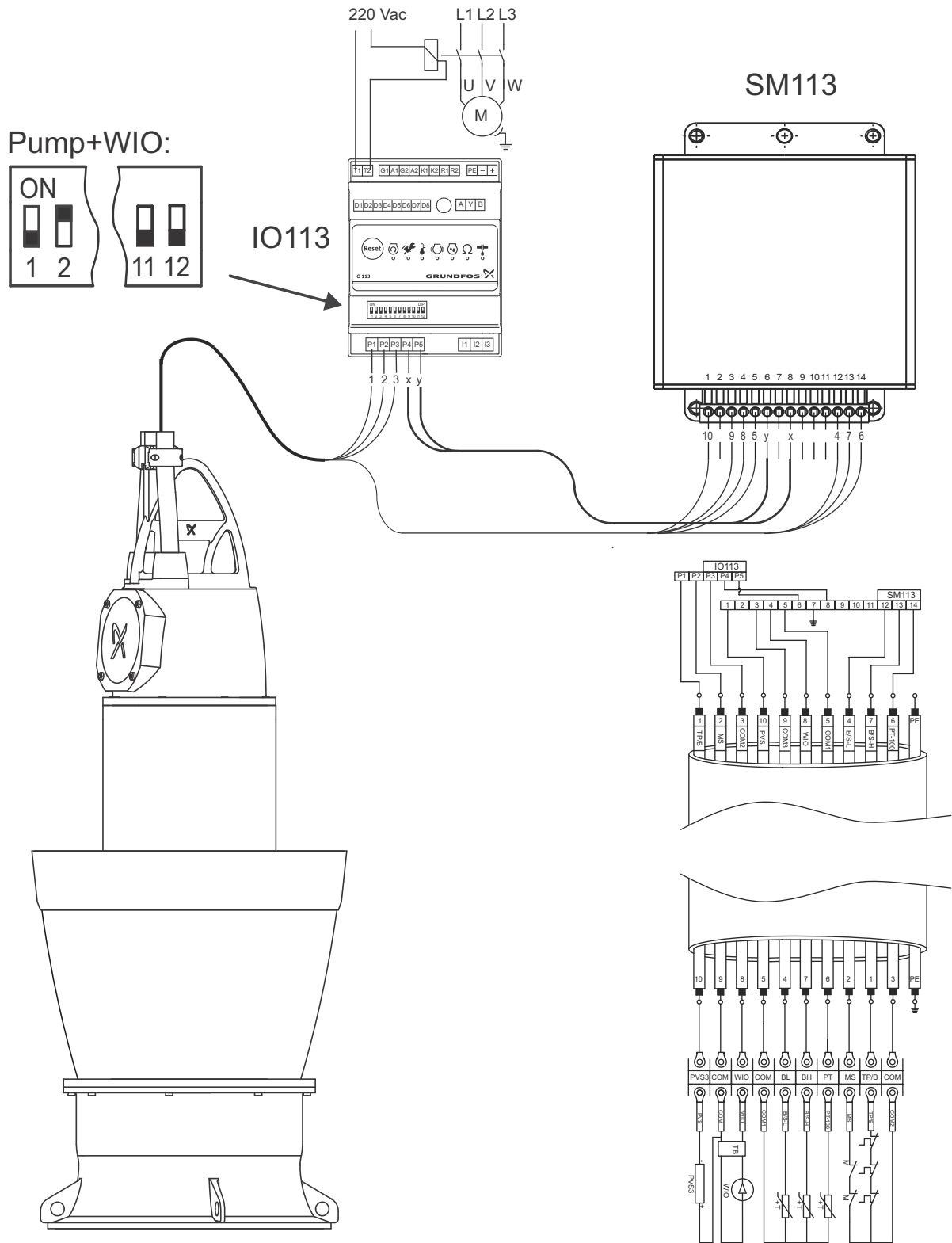

Fig. 116 FPV wiring of IO 113 and SM 113 - outside pump

TM05 9585 4514

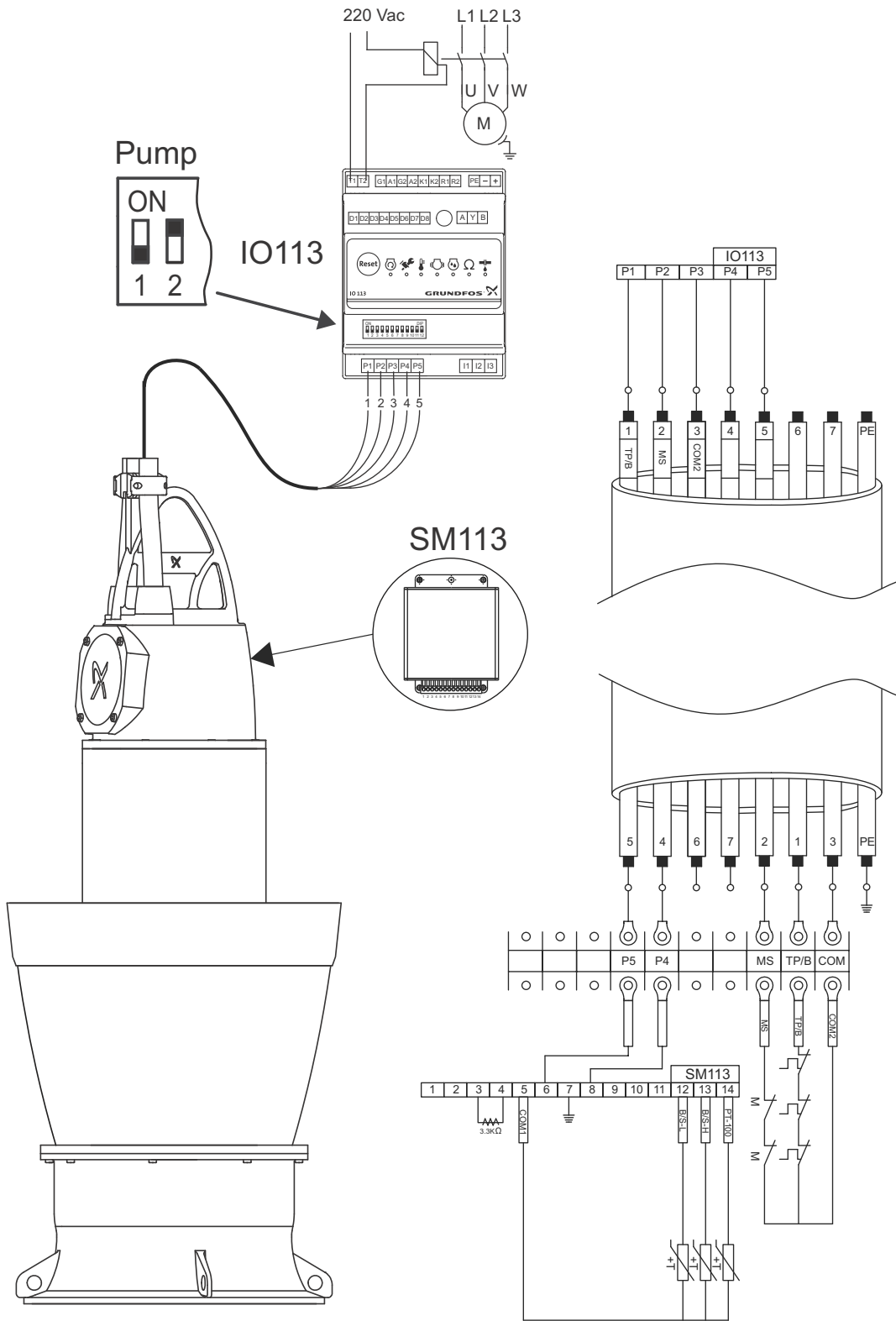

Fig. 117 Standard wiring of IO 113 and SM 113 - inside pump

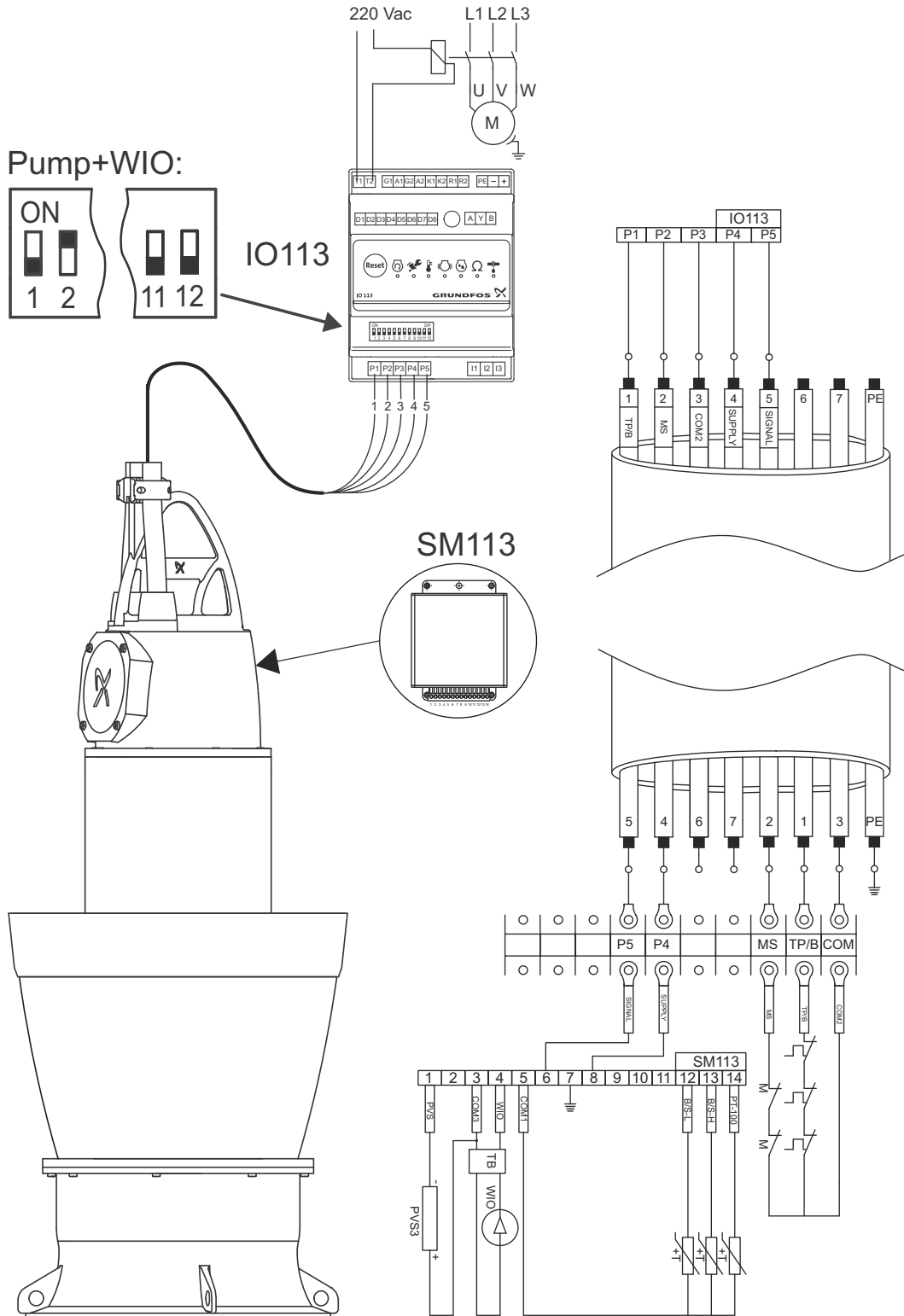
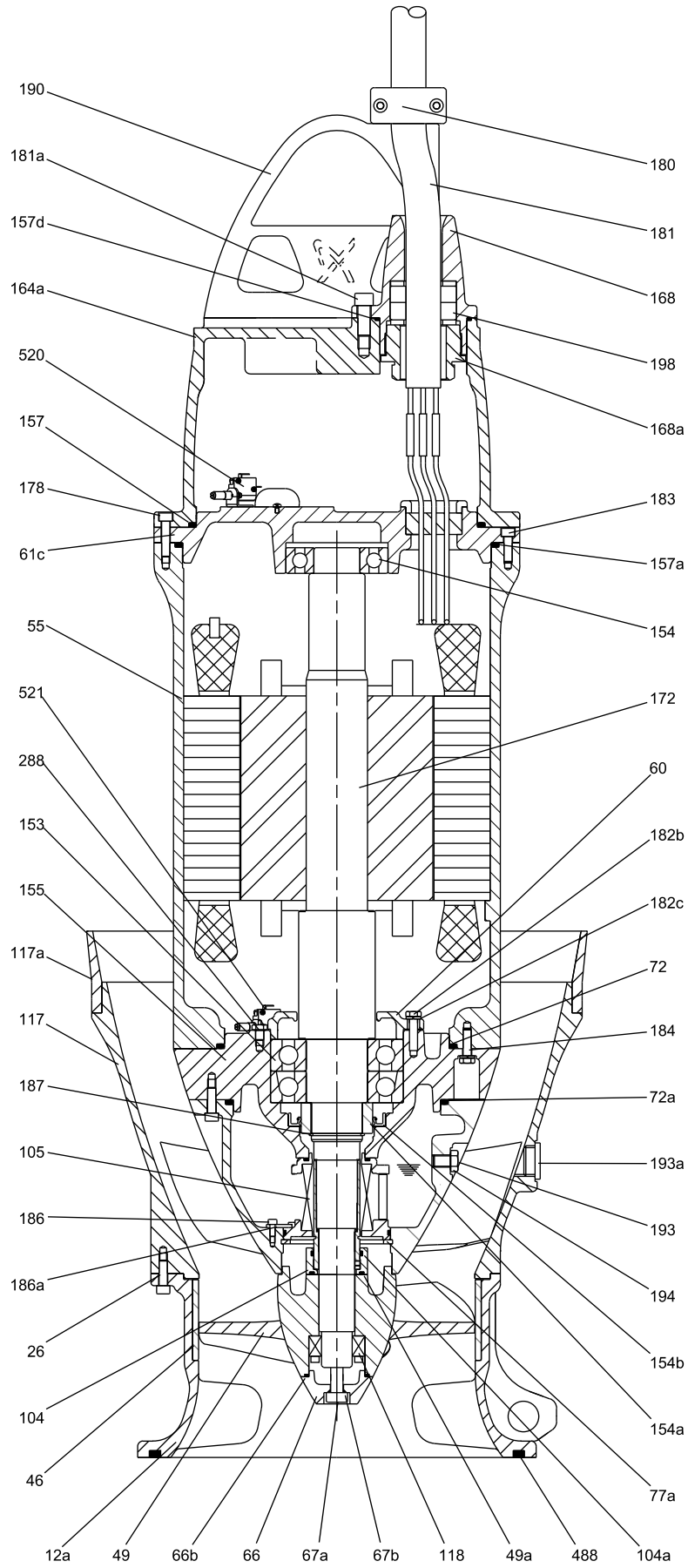

Fig. 118 FPV wiring of IO 113 and SM 113 - inside pump

TIM05 9587 4514

20. Drawings
KPL 500



TM06 2921 4814

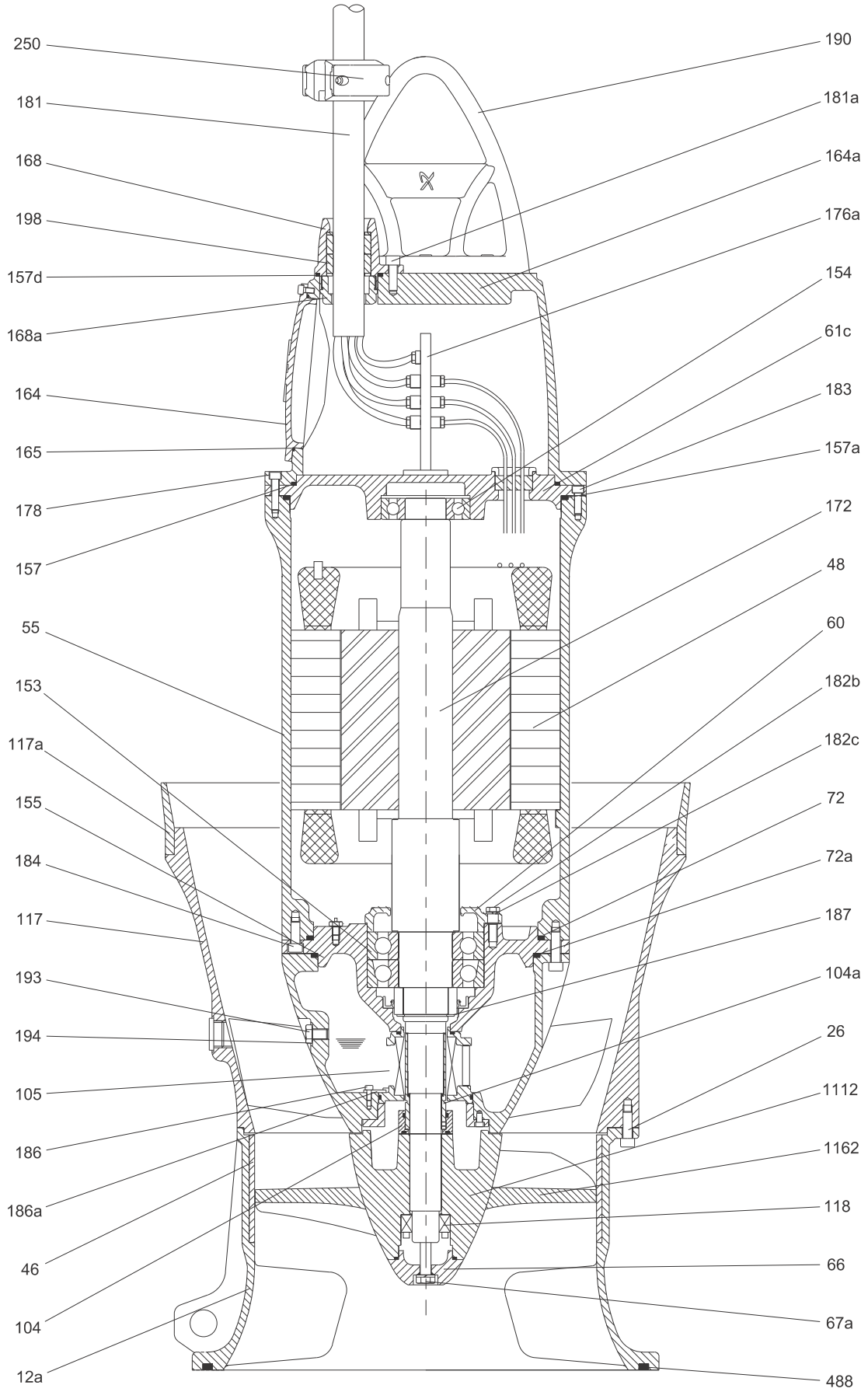

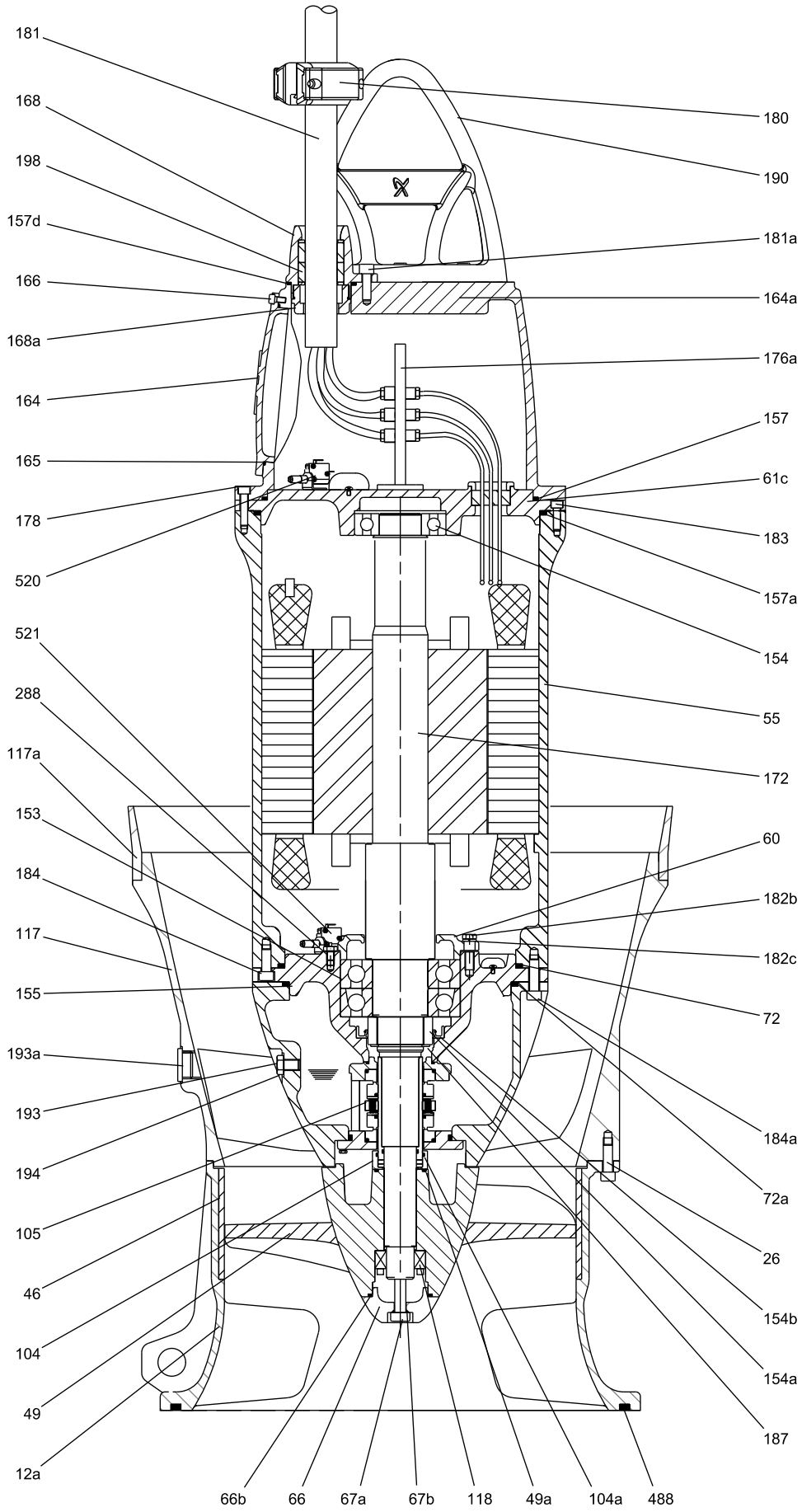

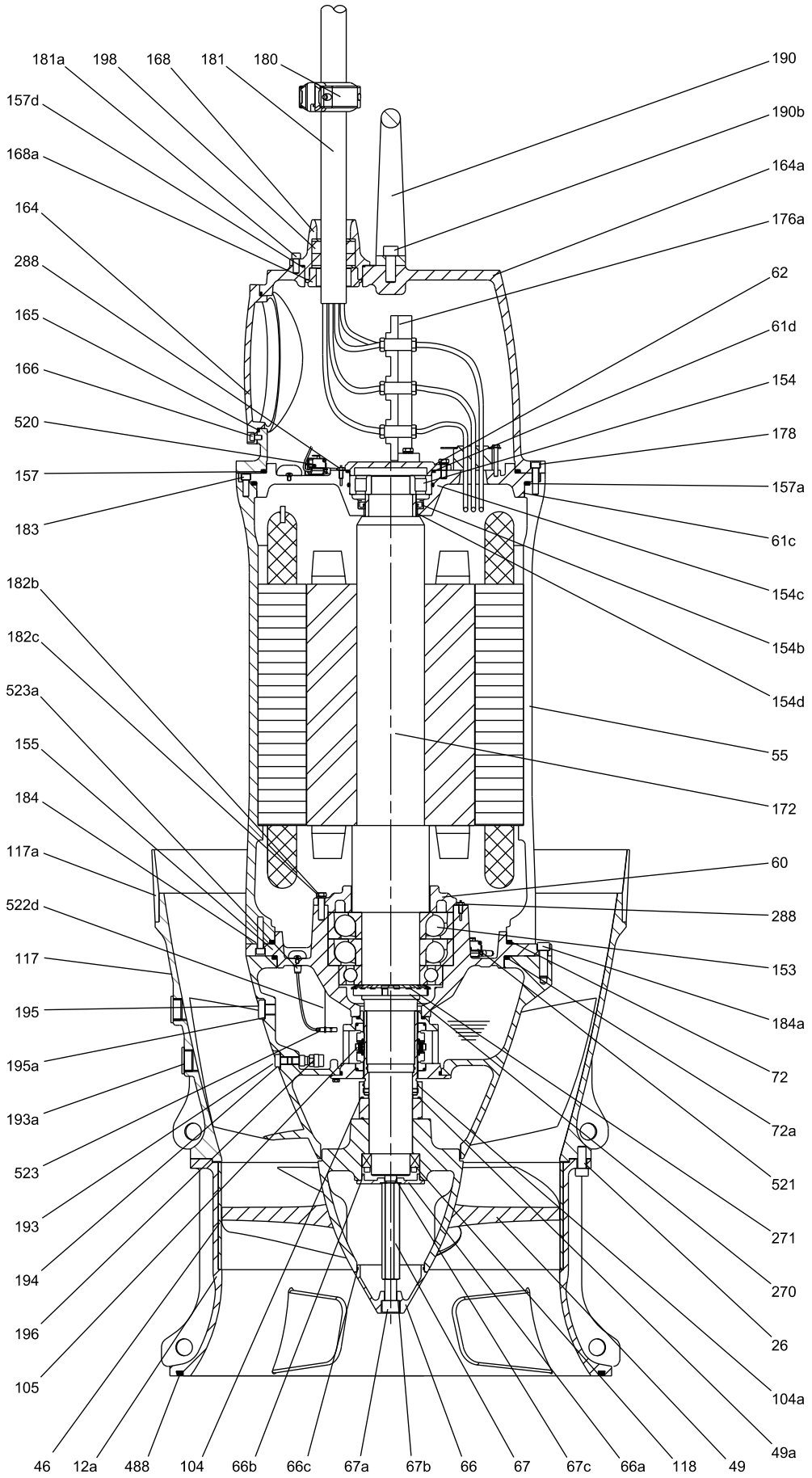

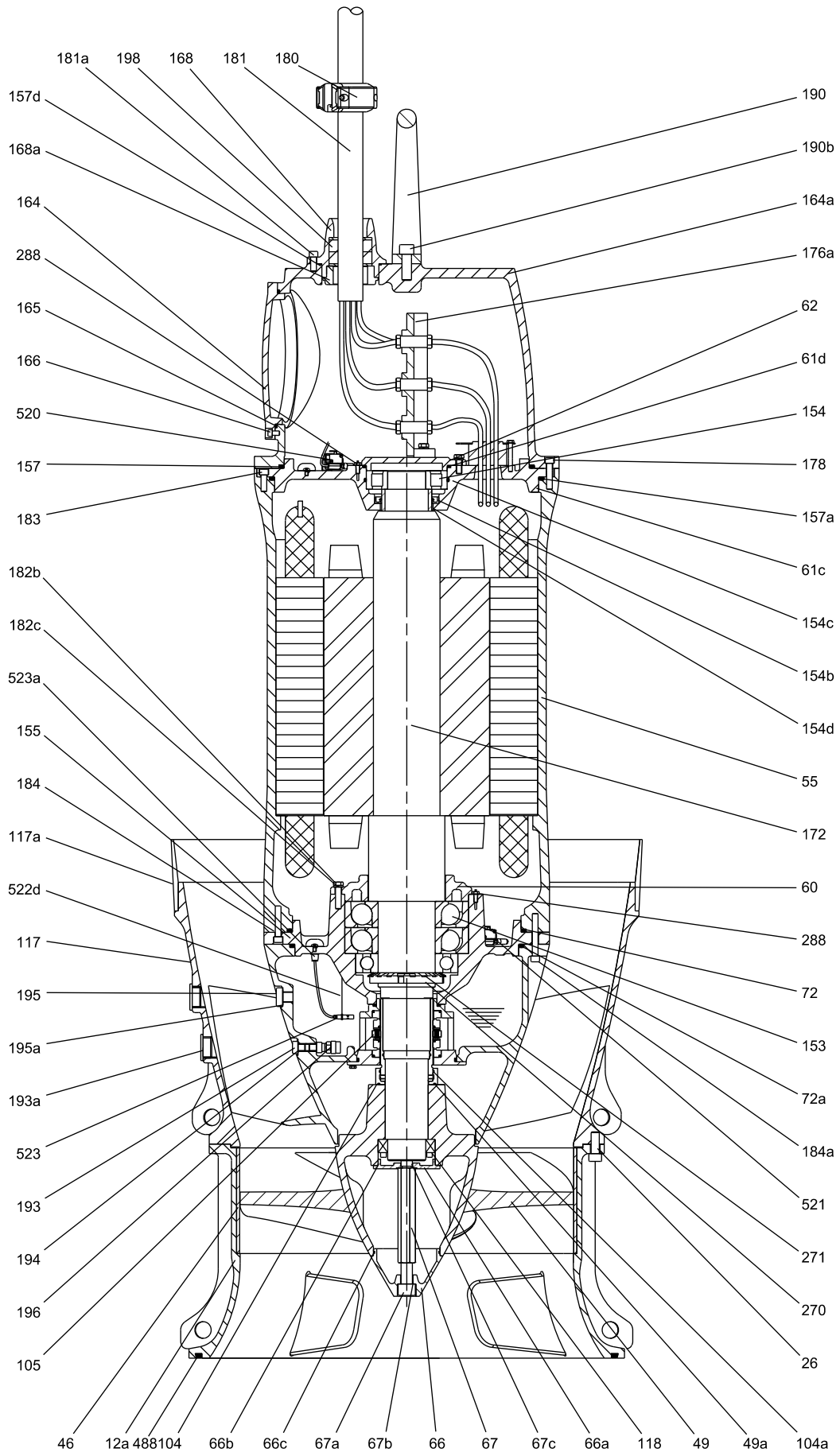

TM06 2926 4814

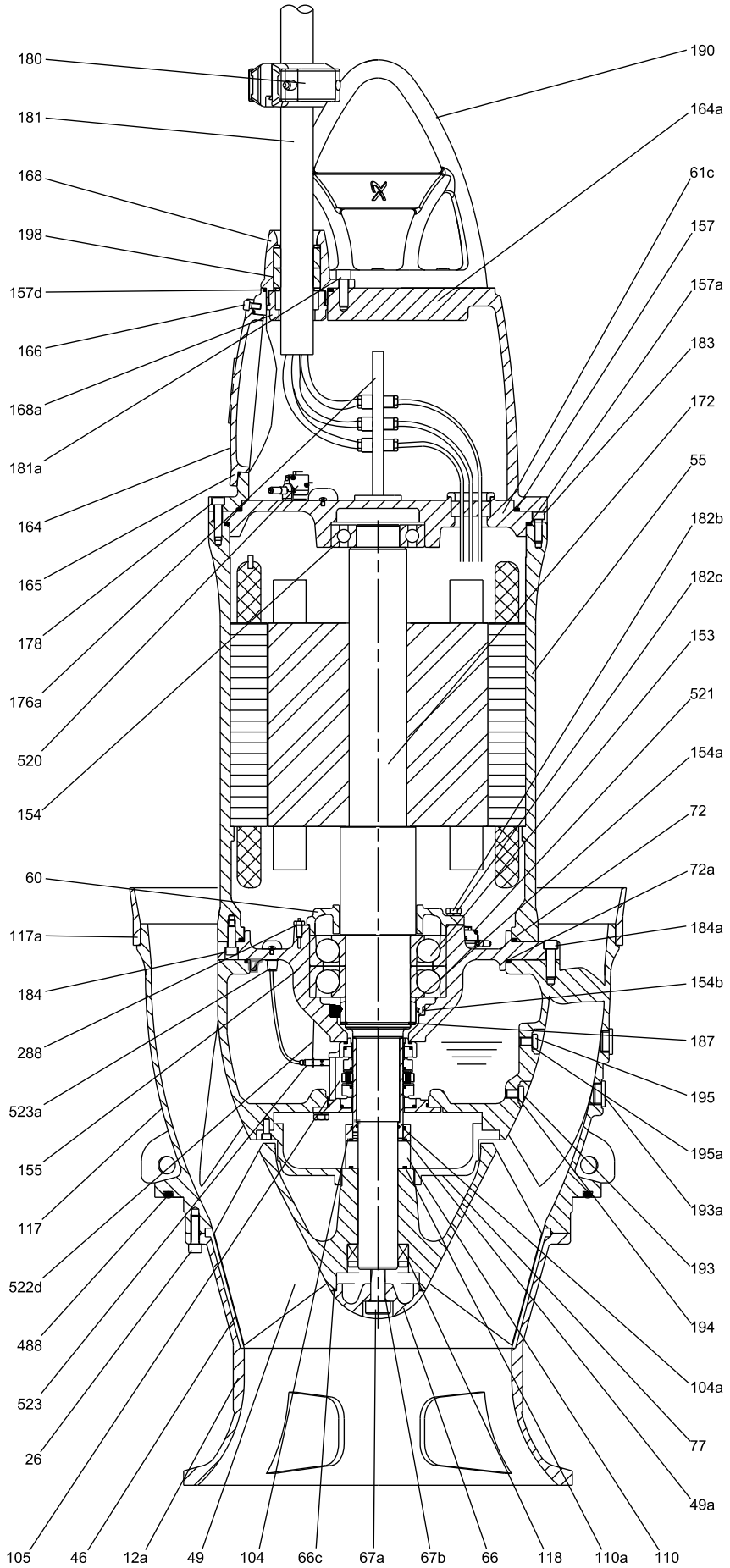

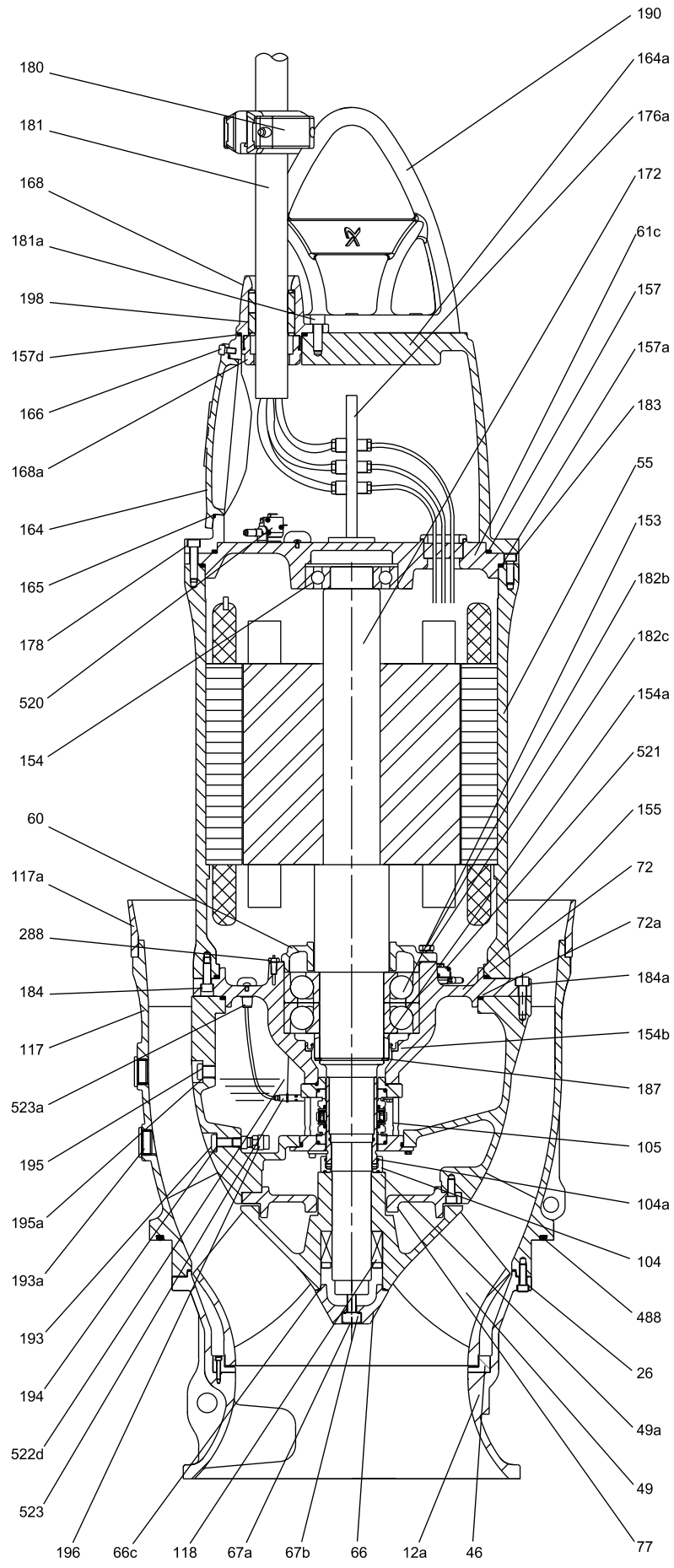

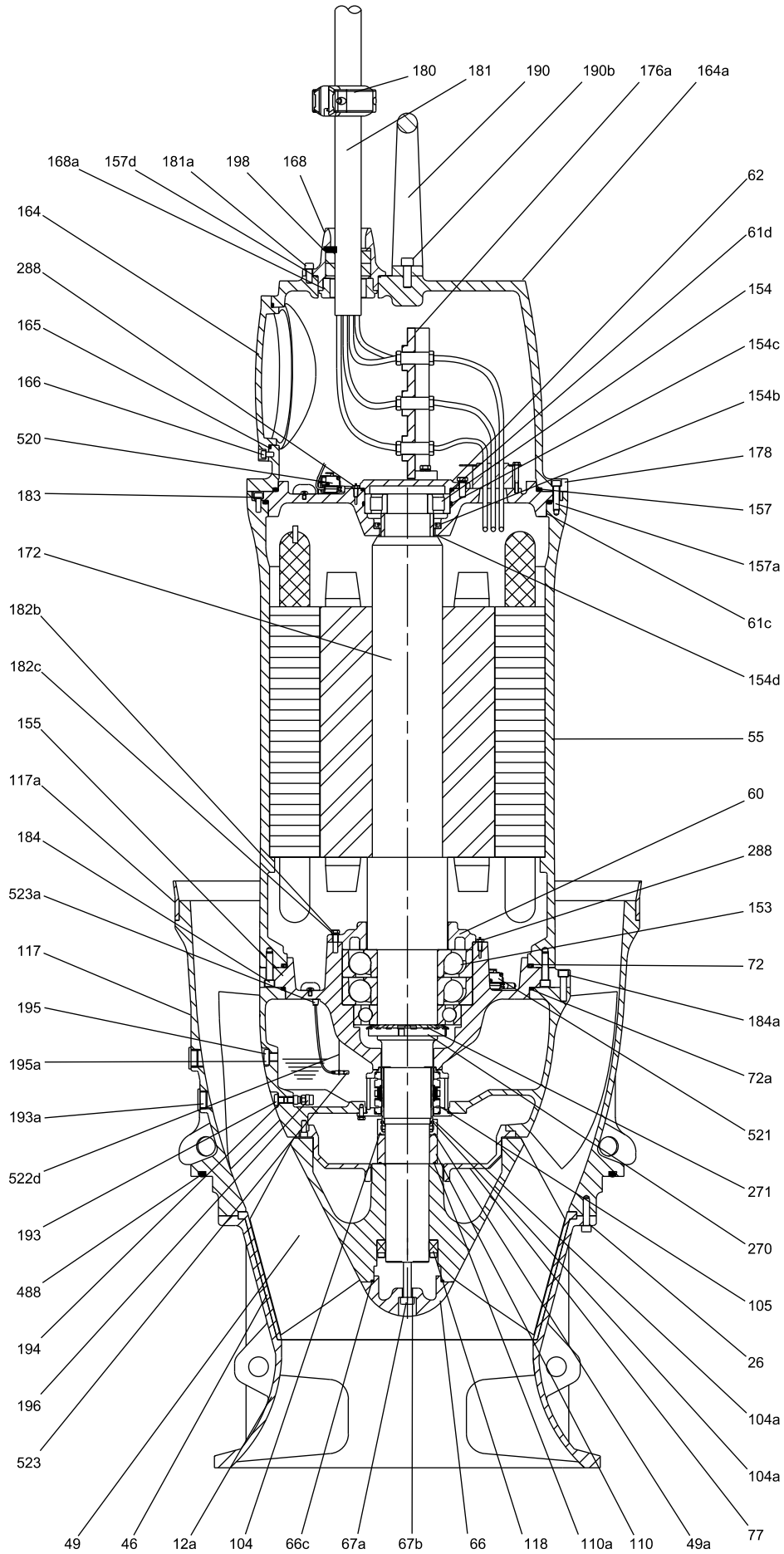

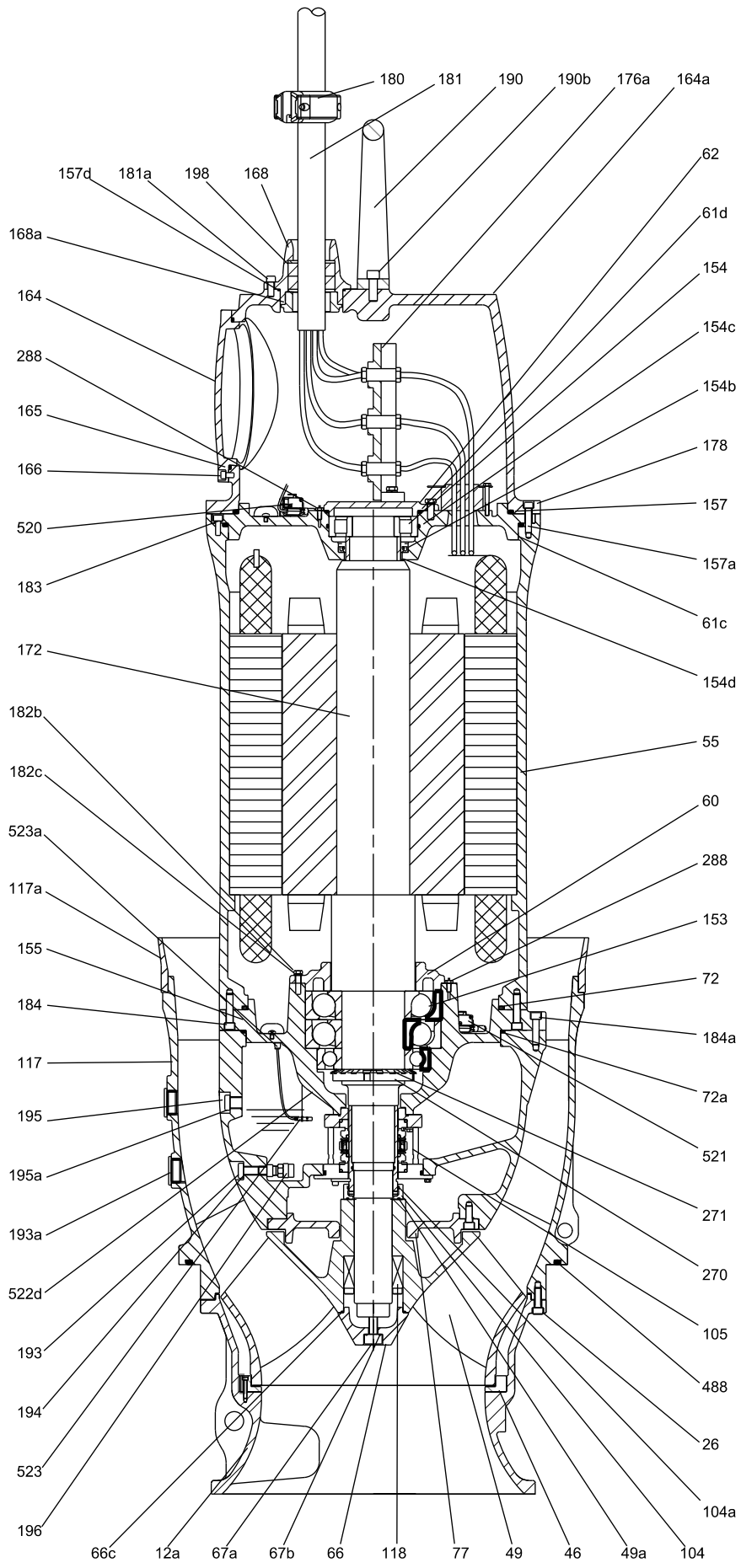

21. List of materials

Pos.	Component	Material	DIN	ASTM
12a	Suction casing	Cast iron	GG25	A48-CL35
26	Screw	Stainless steel	X5CrNi-189-1.4301	A276-304
26a	Screw	Stainless steel	X5CrNi-189-1.4301	A276-304
26b	Washer			
46	Wear ring (KPL)	Stainless steel	X5CrNi-189-1.4301	A276-304
46	Wear ring (KWM)	Ductile cast iron	GGG-40	A536-65-45-12
46a	Set screw			
49a	O-ring	NBR rubber		
49	Impeller (KWM)	Ductile cast iron	GGG-40	A536-65-45-12
49	Propeller (KPL)	Stainless steel	G-X6Cr-Ni-189	A743-CF-8
55	Stator housing	Cast iron	GG25	A48-CL35
60	Bearing cover, lower	Cast iron	GG25	A48-CL35
60a	Screw	Stainless steel	X5CrNi-189-1.4301	A276-304
61c	Bearing bracket, upper	Cast iron	GG25	A48-CL35
61d	O-ring	NBR rubber		
61e	O-ring	NBR rubber		
62	Bearing cover, upper	Cast iron	GG25	A48-CL35
66	Propeller cap (KPL)	Stainless steel	G-X6Cr-Ni-189	A743-CF-8
66	Impeller cap (KWM)	Cast iron	GG25	A743-CF-8
66a	Power-lock® cover (washer)	Stainless steel	X5CrNi-189-1.4301	A276-304
66b	O-ring	NBR rubber		
66c	O-ring	NBR rubber		
67	Support screw			
67a	Hexagon socket head cap screw	Stainless steel	X5CrNi-189-1.4301	A276-304
67b	O-ring	NBR rubber		
67c	O-ring	NBR rubber		
72	O-ring	NBR rubber		
72a	O-ring	NBR rubber		
77	Water chamber			
77a	Circlip	Steel		
104	Seal ring	Stainless steel		
104a	O-ring	NBR rubber		
104b	Set screw	Stainless steel	X5CrNi-189-1.4301	A276-304
105	Shaft seal	SIC/SIC		
105a	O-ring	NBR rubber		
105b	O-ring	NBR rubber		
105c	O-ring	NBR rubber		
105d	Screw	Stainless steel	X5CrNi-189-1.4301	A276-304
105e	Shaft seal lock			
105f	Screw	Stainless steel	X5CrNi-189-1.4301	A276-304
106a	O-ring	NBR rubber		
106b	O-ring	NBR rubber		
110	Intermediate ring	Stainless steel	X5CrNi-189-1.4301	A276-304
110a	O-ring	NBR rubber		
117	Discharge casing	Cast iron	GG25	A48-CL35
117a	Turbulence optimiser	Rubber		
117b	Screw	Stainless steel	X5CrNi-189-1.4301	A276-304
117c	Discharge casing protector			
117d	Screw	Stainless steel	X5CrNi-189-1.4301	A276-304
118	Power-lock®	Steel		
153	Ball bearing	Steel		
153a	Ball bearing	Steel		
154	Ball bearing	Steel		
154a	Shaft sleeve			
154b	Seal ring	NBR rubber		

Pos.	Component	Material	DIN	ASTM
154c	O-ring	NBR rubber		
154d	Sleeve (top bearing)			
155	Bearing bracket, lower	Cast iron	GG25	A48-CL35
157	O-ring	NBR rubber		
157a	O-ring	NBR rubber		
157d	O-ring	NBR rubber		
157e	O-ring	NBR rubber		
164	Terminal box cover	Cast iron	GG25	A48-CL35
164a	Motor top cover	Cast iron	GG25	A48-CL35
165	O-ring	NBR rubber		
166	Screw	Stainless steel	X5CrNi-189-1.4301	A276-304
166a	Washer	Stainless steel	X5CrNi-189-1.4301	A276-304
168	Cable entry	Stainless steel	G-X6Cr-Ni-189	A743-CF-8
168a	Cable entry, lower, power cable	Cast iron	GG25	A48-CL35
168b	Cable entry, lower, sensor cable	Cast iron	GG25	A48-CL35
168c	Cable entry, stator housing	Stainless steel	G-X6Cr-Ni-189	A743-CF-8
172	Shaft with rotor	Stainless steel	X10Cr13	A276-410
173	Screw	Stainless steel	X5CrNi-189-1.4301	A276-304
173b	Cable shoe for earth connection			
176a	Terminal board			
176b	Screw	Stainless steel	X5CrNi-189-1.4301	A276-304
176c	Washer	Stainless steel	X5CrNi-189-1.4301	A276-304
177c	Cable gland	NBR rubber		
178	Screw	Stainless steel	X5CrNi-189-1.4301	A276-304
178a	Washer	Stainless steel	X5CrNi-189-1.4301	A276-304
180	Cable clamp	Stainless steel	X5CrNi-189-1.4301	A276-304
180a	Screw	Stainless steel	X5CrNi-189-1.4301	A276-305
180b	Screw	Stainless steel	X5CrNi-189-1.4301	A276-306
181	Cable	PNCT		
181a	Screw	Stainless steel	X5CrNi-189-1.4301	A276-304
181b	Washer	Stainless steel	X5CrNi-189-1.4301	A276-304
181c	Screw	Stainless steel	X5CrNi-189-1.4301	A276-304
182b	Screw	Stainless steel	X5CrNi-189-1.4301	A276-304
182c	Washer	Stainless steel	X5CrNi-189-1.4301	A276-304
183	Screw	Stainless steel	X5CrNi-189-1.4301	A276-304
184	Screw	Stainless steel	X5CrNi-189-1.4301	A276-304
184a	Screw	Stainless steel	X5CrNi-189-1.4301	A276-304
184c	Washer	Stainless steel	X5CrNi-189-1.4301	A276-304
186	Screw	Stainless steel	X5CrNi-189-1.4301	A276-304
186a	Seal bracket	Cast iron	GG25	A48-CL35
187	Circlip			
190	Lifting bracket	Stainless steel	G-X6Cr-Ni-189	A743-CF-8
190b	Screw	Stainless steel	X5CrNi-189-1.4301	A276-304
193	Plug	Stainless steel	X5CrNi-189-1.4301	A276-304
193a	Plug	Stainless steel	X5CrNi-189-1.4301	A276-304
193b	Non-return valve			
194	O-ring	NBR rubber		
195	Plug			
195a	O-ring			
196	Non-return valve			
198	Washer/rubber seal/washer	Stainless steel/NBR rubber		
198e	Cable gland	NBR rubber		
198f	Cable gland	NBR rubber		
199	Cable gland	NBR rubber/steel		
199a	Screw	Stainless steel	X5CrNi-189-1.4301	A276-304

Pos.	Component	Material	DIN	ASTM
250b	Washer/rubber seal/washer	Stainless steel/NBR rubber		
252	Sensor cable			
270	Lock nut	Steel		
271	Lock washer	Steel		
288	Bearing temperature sensor			
488	O-ring	NBR rubber		
520	Moisture switch, upper			
520c	Screw	Stainless steel	X5CrNi-189-1.4301	A276-304
521	Moisture switch, lower			
521a	Washer	Stainless steel	X5CrNi-189-1.4301	A276-304
521b	Screw	Stainless steel	X5CrNi-189-1.4301	A276-304
522a	Cross head screw M6x10	Stainless steel	X5CrNi-189-1.4301	A276-304
522b	Spring washer M6 Zn DIN 127			
522d	Sensor bracket for WIO			
523	WIO sensor			
523a	Cable gland			
528	PVS 3 pump vibration sensor			
529	SM 113			

22. Exploded views

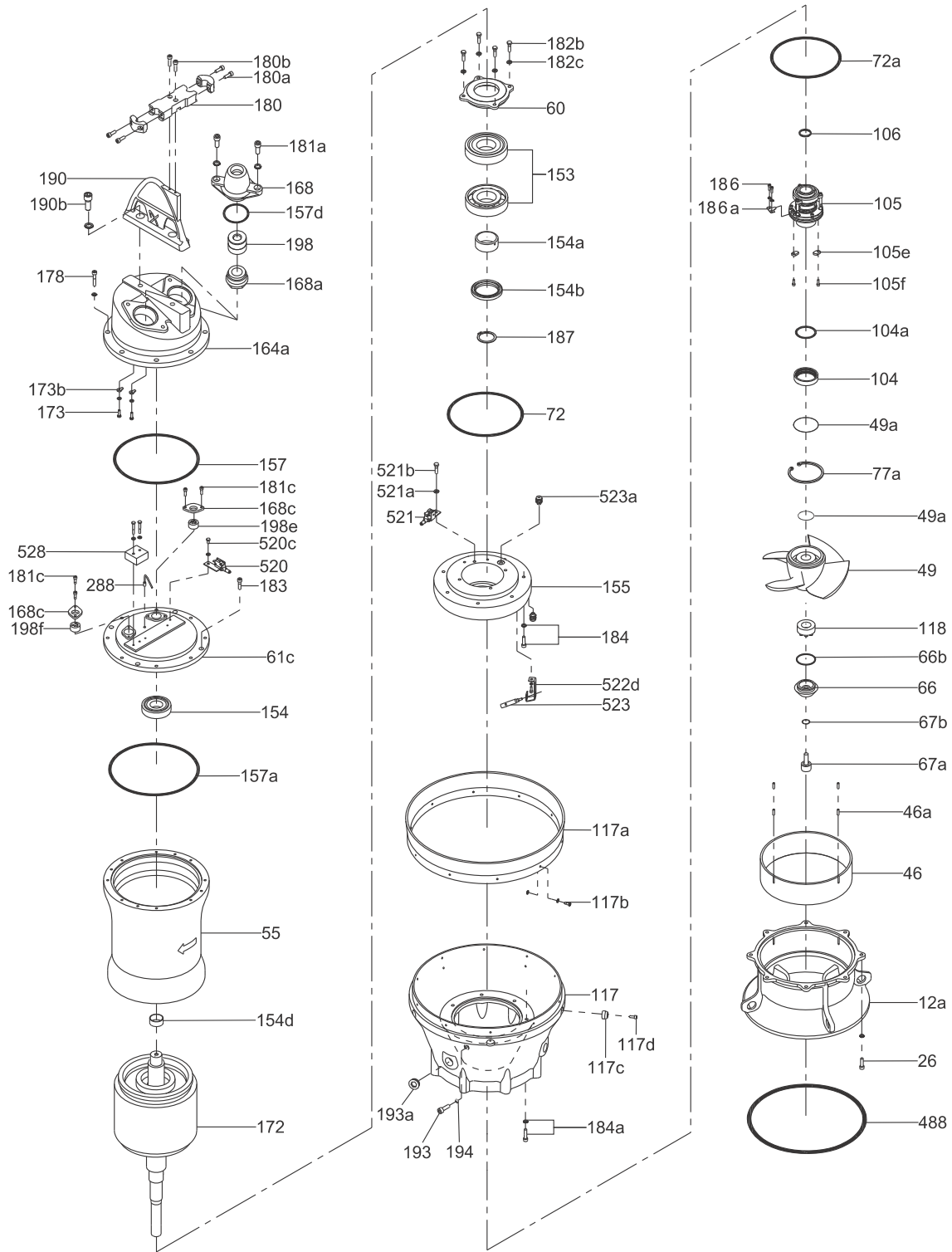

Fig. 119 Exploded view, KPL 500

TM06 0241 3814

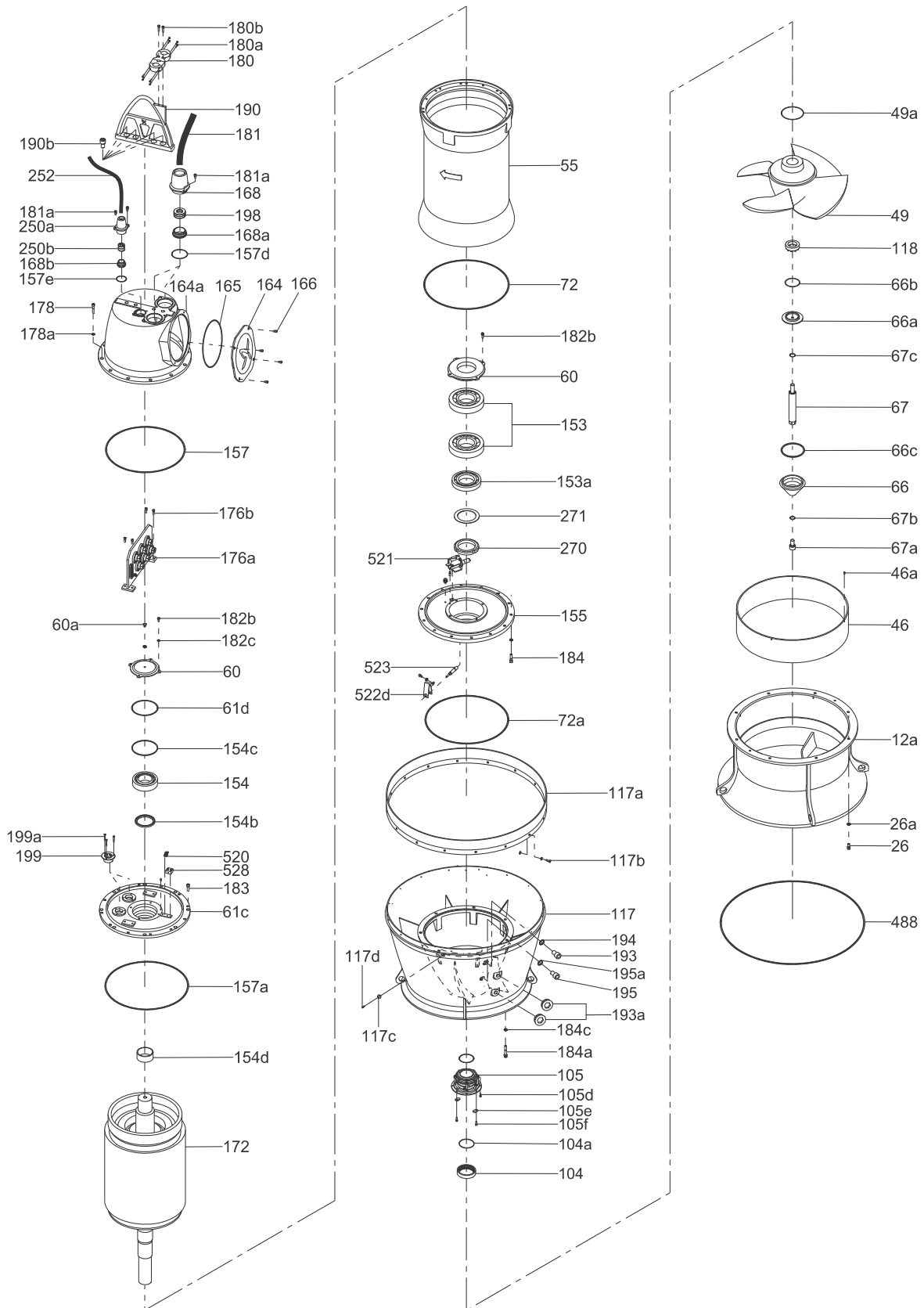

Fig. 120 Exploded view, KPL 1800

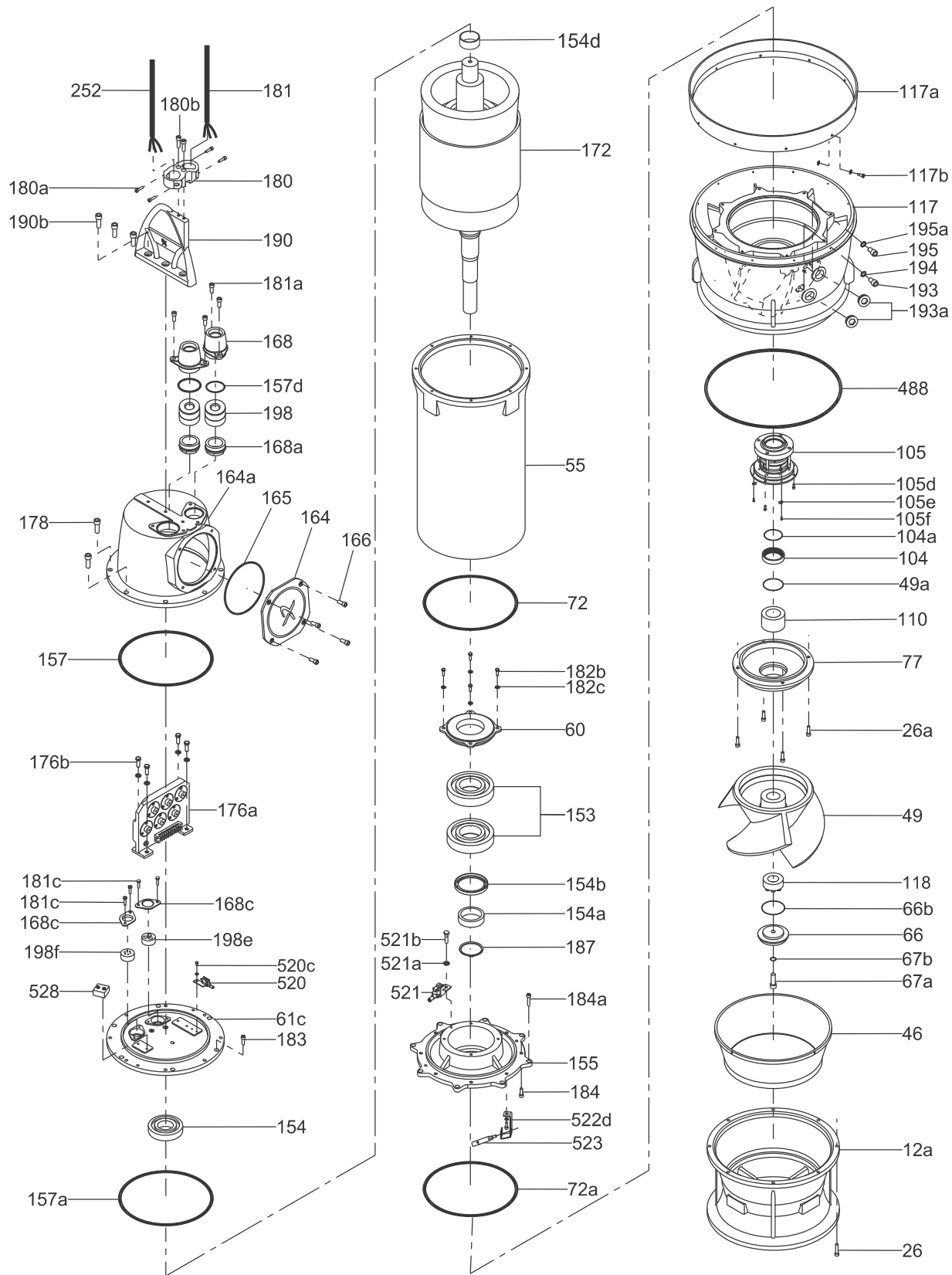

Fig. 121 Exploded view, KWM 700

TM06 0239 3814

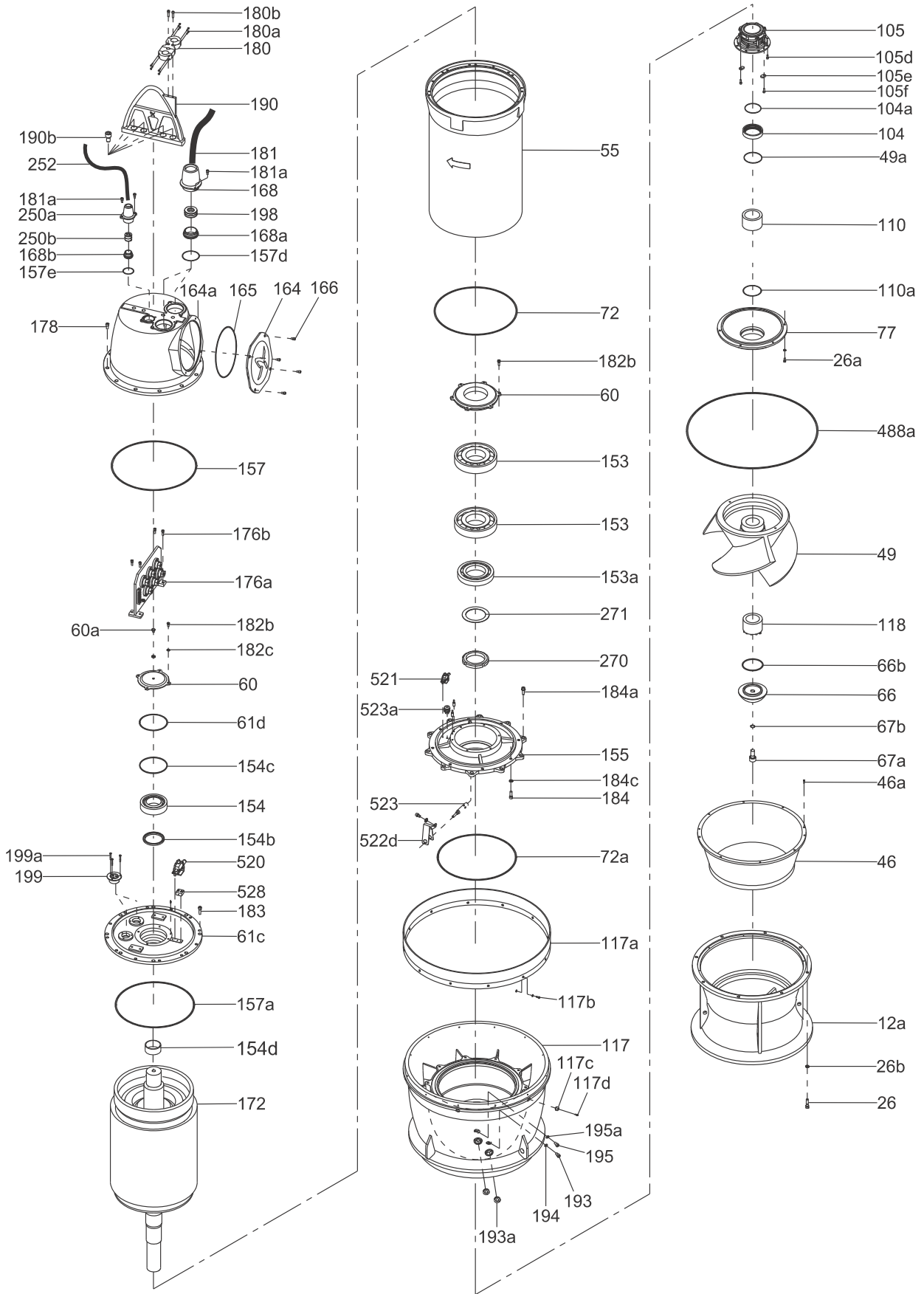

Fig. 122 Exploded view, KWM 1200

23. Resistance table for the Pt100 sensor

°C	0	1	2	3	4	5	6	7	8	9
-50	80.31	79.91	79.51	79.11	78.72	78.32	77.92	77.52	77.13	76.73
-40	84.27	83.88	83.48	83.08	82.69	82.29	81.89	81.50	81.10	80.70
-30	88.22	87.83	87.43	87.04	86.64	86.25	85.85	85.46	85.06	84.67
-20	92.16	91.77	91.37	90.98	90.59	90.19	89.80	89.40	89.01	88.62
-10	96.09	95.69	95.30	94.91	94.52	94.12	93.73	93.34	92.95	92.55
0	100.00	99.61	99.22	98.83	98.44	98.04	97.65	97.26	96.87	96.48
0	100.00	100.39	100.78	101.17	101.56	101.95	102.34	102.73	103.12	103.51
10	103.90	104.29	104.68	105.07	105.46	105.85	106.24	106.63	107.02	107.40
20	107.79	108.18	108.57	108.96	109.35	109.73	110.12	110.51	110.90	111.28
30	111.67	112.06	112.45	112.83	113.22	113.61	113.99	114.38	114.77	115.15
40	115.54	115.93	116.31	116.70	117.08	117.47	117.85	118.24	118.62	119.01
50	119.40	119.78	120.16	120.55	120.93	121.32	121.70	122.09	122.47	122.86
60	123.24	123.62	124.01	124.39	124.77	125.16	125.54	125.92	126.31	126.69
70	127.07	127.45	127.84	128.22	128.60	128.98	129.37	129.75	130.13	130.51
80	130.89	131.27	131.66	132.04	132.42	132.80	133.18	133.56	133.94	134.32
90	134.70	135.08	135.46	135.84	136.22	136.60	136.98	137.36	137.74	138.12
100	138.50	138.88	139.26	139.64	140.02	140.39	140.77	141.15	141.53	141.91
110	142.29	142.66	143.04	143.42	143.80	144.17	144.55	144.93	145.31	145.68
120	146.06	146.44	146.81	147.19	147.57	147.94	148.32	148.70	149.07	149.45
130	149.82	150.20	150.57	150.95	151.33	151.70	152.08	152.45	152.83	153.20
140	153.58	153.95	154.32	154.70	155.07	155.45	155.82	156.19	156.57	156.94
150	157.31	157.69	158.06	158.43	158.81	159.18	159.55	159.93	160.30	160.67
160	161.04	161.42	161.79	162.16	162.53	162.90	163.27	163.65	164.02	164.39
170	164.76	165.13	165.50	165.87	166.24	166.61	166.98	167.35	167.72	168.09
180	168.46	168.83	169.20	169.57	169.94	170.31	170.68	171.05	171.42	171.79
190	172.16	172.53	172.90	173.26	173.63	174.00	174.37	174.74	175.10	175.47
200	175.84	176.21	176.57	176.94	177.31	177.68	178.04	178.41	178.78	179.14

98383809 0515
ECM: 1159109