

IRRIGATION PUMP HANDBOOK

be
think
innovate

GRUNDFOS 



CONTENTS

INTRODUCTION

– the importance of pump selection for irrigation	4	7. CHEMIGATION AND FERTIGATION	42
The Irrigation Pump Handbook	5	Accuracy and uniformity	45
Correct pump selection	5	Let the irrigation system do the work	46
1. AVAILABILITY OF WATER	8	Precision application of liquid fertiliser	47
Water cycle	10	Digital dosing pumps	48
Groundwater	10	How to size a fertigation pump	49
Surface water	11	8. CONTROLS, INFORMATION AND AUTOMATION	50
Rainwater harvesting	11	Controls and monitoring	52
Water storage – basins, tanks and water bank	11	Remote management and data communication	52
2. SOIL-WATER-PLANT RELATIONSHIPS	12	Add a VFD for optimal efficiency	53
Soil types	14	How costs are saved	54
Infiltration rate	14	9. RENEWABLE ENERGY SOURCES	56
Water quality and treatment	16	Renewables a solid investment	58
Plant relationships	17	How does a renewable energy source pump work?	59
Other water issues	17	10. BASIC HYDRAULICS	60
3. WHAT IS IRRIGATION?	18	The fundamentals	62
Defining irrigation	20	Friction loss	63
A brief history	20	Vapor pressure	63
Critical applications – nurseries and greenhouses	21	11. PUMPS AND MOTORS	64
Non-agricultural irrigation	21	Centrifugal pump types	66
4. BASIC IRRIGATION OPERATION	22	Cavitation	67
Achieving an effective and efficient irrigation	24	Pump performance	68
Distribution Uniformity and Irrigation Efficiency	24	Performance regulation	69
Relationships between DU and IE	24	Electric motors	71
Irrigation scheduling	26	Motor protection	72
5. TRADITIONAL FLOOD IRRIGATION	28	12. PUMP SIZING	74
Why flood irrigate	30	Groundwater wells	78
Types of flood irrigation	31	13. PUMP PERFORMANCE	74
Components & equipment	31	14. PUMP OVERVIEW	84
6. MODERN PRESSURISED IRRIGATION	32	Technical overview	86
Sprinkler systems	34	Range overview	87
Drip irrigation	36	15. THE FUTURE – SUSTAINABLE AGRICULTURE	88
Components for pressurised irrigation	38	Automation and intelligence	90
Types of filtration equipment	41	The increasing importance of the pump	90
		16. GLOSSARY	92



INTRODUCTION

— THE IMPORTANCE OF PUMP SELECTION FOR IRRIGATION

NATURE, IT IS OFTEN SAID, IS TRULY AMAZING. WITH THE RIGHT COMBINATION OF SUN, SOIL, TEMPERATURE AND WATER, PLANT LIFE CAN FLOURISH. SOMETIMES HOWEVER, NATURE CAN USE A HELPING HAND.

Adding water through irrigation has been practiced for thousands of years. Irrigation can enhance both crop quality and quantity and it can even do so in areas where precipitation already can sustain agriculture. For recreational activities, irrigation keeps playing surfaces lush and attractive.

Proper irrigation requires growers to understand soil properties, climatology, hydraulics, botany, and engineering. Effective, efficient irrigation is the result of knowing when and how much to irrigate. Making the best possible use of the water supply with a minimal impact on water quality minimises energy costs and therefore saves the owner money.

THE IRRIGATION PUMP HANDBOOK

This Irrigation Pump Handbook is a comprehensive presentation of modern irrigation today, and what has gone before. Our aim is not to provide a 'how-to' guide to building an irrigation system; rather it is to explain why an irrigation system is complex, and to make that complexity understandable.

This is to help the farmer and the installer make the right decisions, ensuring that the right solution is chosen, from system layouts, to our recommendations for which pumps may be employed in irrigation systems.

Grundfos' experience with water supply pumps goes all the way back to our earliest years. In fact, a water supply pump was the very first pump we ever created. Today, our product portfolio features submersible pumps, vertical turbine pumps, end suction pumps, horizontal split-case pump, Smart and digital dosing pumps, multi-stage in-line pumps, variable frequency drives (VFD), chemical feed and pressure boosting pumps for all needs. We provide pumps for groundwater systems and surface water systems.

We are never far away from the people who need us. Our local facilities and partners ensure that pumps, replacement parts and expert advisors are always close at hand. A global company, Grundfos can be found in all major agricultural centers.

To better serve farmers and irrigation system suppliers, Grundfos has brought in the Paco and Peerless product ranges to create a formidable line-up of pumping systems for irrigation.

Each company has a long-standing position and experience with agricultural applications. From deep-set turbines to surface boosting operations, we have the products and expertise to meet irrigation needs going forward. Our respective heritages and contributions put us in a unique position to understand the historical needs of the market and to help farming communities meet the challenges ahead.

Grundfos wishes to thank the Center for Irrigation Technology (CIT) at California State University Fresno and the Irrigation Association (IA) for their cooperation in the preparation of this book.

CORRECT PUMP SELECTION

Pump selection is crucial to ensuring that the farmer's irrigation design layout meets the precise requirements for the crop and optimises irrigation efficiency. These requirements are satisfied if the pump matches the irrigation system, flow pressure is kept low, and controls are used. This is where Grundfos comes in, and a brief introduction to pump selection follows.

Different types of irrigation techniques place varied demands on how water is pumped from the source and distributed within the field. The goal is to supply the entire field uniformly with water using the least amount of energy, ensuring that each plant has the amount of water it needs, neither too much nor too little. Modern irrigation methods are efficient enough to achieve this goal, and having the right pump is crucial.

Irrigating an entire field uniformly is best accomplished by dividing the area to be irrigated into zones. A zone can be defined according to irrigation need, types of crops, and soil type and is often served by a single irrigation valve that provides water to a large number of drippers, surface or sub-surface tape products or sprinklers that are connected by pipes or tubes. Irrigation systems are divided into zones because there is usually not enough pressure and available flow to run the irrigation system for an entire field at any one time. An irrigation controller – either mechanical or, increasingly, electrical and online – signals a zone to turn on at a specific time and keeps it on for a specified amount of time. Center pivots typically are operated by one pump and do not have zones, as when the pump is turned on, the pivot operates as well.

Select irrigation equipment first

Different irrigation equipment requires different amounts of water and pressure, and the equipment must therefore be selected before selecting the pump. The controller must not be overlooked. With pump performance controlled, irrigation can be turned on and off during predefined periods. Water can be conserved by not irrigating in direct sunlight, or when winds are heavy.

A controller can be programmed to optimise operation with due respect to both the crop and water conservation, for example by turning the pump off for a time will allow the soil to absorb the irrigated water. Engaging it later on will improve infiltration rate and reduce run off.

Smart pump control for irrigation is becoming more widespread, as farmers better understand the benefits of computer-controlled systems and distributors become better at including monitoring and control in their service offerings to farmers. Weather data, soil moisture sensors, and rain sensors can all play together with pressure control for fully automated irrigation systems.

Consider the water source

Successful agriculture is dependent upon farmers having sufficient access to water. Looking back to the middle of the last century, the common perception was that water was an infinite resource. Today, we are aware that water is a resource that needs to be managed. This is not only a question of more mouths to feed, people today consume more calories and eat more meat, and this requires more water to produce food. To meet future demands, world food production must double by 2045.

Sources of irrigation water can be groundwater extracted from springs or by using wells, surface water drawn from rivers, canals, lakes or reservoirs or non-conventional sources like treated wastewater, desalinated water, drainage water, or reclaimed water generally.

The location of the irrigation water makes a difference to the pump that should be selected. Deep-well submersible pumps and turbine pumps are specially designed to lift water from several hundred feet underground, and a variety of pumps can be used when drawing surface water.

If submersible pumps are used when drawing water from a reservoir or lake, advantages are improved theft protection, because the pumps are submerged, and reduced noise, because noise is limited to that from the pipes and the valves. The majority of North American farmers use oil-lubricated vertical turbine pumps in locations where noise is not a factor. These pumps also provide easy access to the motor for any service or replacement that may be required.

Two basic elements are crucial to ensure flow of water to the irrigation system: the availability of water, and the crop's need for water.

If the source is groundwater, the recommendation is to use more than one well in order to minimise drawdown. Furthermore, employing several small pumps rather than one large pump offers many benefits, including easy cut in/cut out of pumps according to flow demand, reduced aquifer drawdown, thereby reducing energy consumption as lifting height is limited, and avoiding negative influences on the aquifer. If one pump is to be used with a requirement of a wide range of flows due to zones or different crop types and water requirements, a variable frequency drive (VFD) may be a good choice.

A basis for pump selection

Pumps for irrigation have typically been over-sized. Choosing a correctly sized pump is crucial to the success of the irrigation system, and things to consider include keeping power consumption low, maintaining system pressure, and adding variable speed control (using a VFD) and motor protection.

Today, pumps have to be much more integrated with the rest of the irrigation system. This means the pump must be designed to match the rest of the irrigation equipment, or the irrigation equipment must be designed to match the pump.

Taking power consumption first, pumps and motors have different efficiencies, and the overall efficiency should always be calculated before the final selection is made. The electricity bill will depend on how many kW the motor absorbs. Simply compare the flow and head produced by the pump with the kW consumption of the motor. Most pump manufacturers are able to provide all relevant data, so a true calculation of the efficiency can be made.

**TWO BASIC ELEMENTS ARE
CRUCIAL TO ENSURE FLOW OF
WATER TO THE IRRIGATION
SYSTEM: THE AVAILABILITY
OF WATER, AND THE CROP'S
NEED FOR WATER.**

Keeping system pressure as low as possible is an effective way of reducing leakages, conserving water and reducing energy consumption. However, a specific minimum pressure for proper functioning is usually necessary, and without this, the correct performance of the irrigation equipment cannot be guaranteed.

The pump must do more than simply deliver water to the pipes in order to be effective. For example, adding a VFD improves the efficiency of groundwater withdrawal when pumping directly into an irrigation system. Surface water intake and distribution can be improved by using multi-pump pressure boosting systems, and across the board, monitoring and control systems further safeguard the reliable flow of water by protecting the pump from dry-running, motor breakdown or power supply irregularities. Motor protection ultimately saves on maintenance and service checks.

An integrated design means cost savings

All these elements must be fully integrated into the design to provide the benefits that a modern irrigation pumping system can offer the farmer. Maintaining correct pressure and flow in the pipes and at the nozzle means more water per kWh and savings on energy, which is one of the highest cost drivers in farming.

If the pump matches the irrigation system, if pressure is not higher than necessary, and if controls are used, then operating costs generally are lowered. Water delivered with greater precision to the crop results in a better harvest, increased profitability and better water management, ensuring sustainable agriculture in the future.



WATER CYCLE	10
GROUNDWATER	10
SURFACE WATER	11
RAIN HARVESTING	11
WATER STORAGE – BASINS, TANKS AND WATER BANK	11



01

AVAILABILITY OF WATER

IDENTIFYING THE CHARACTERISTICS OF YOUR WATER SOURCE IS VITAL FOR THE QUALITY OF YOUR IRRIGATION. DIFFERENT WATER SOURCES MUST OF COURSE BE MANAGED DIFFERENTLY.

THE PERFORMANCE OF THE PUMP RELIES HEAVILY ON A SYSTEMATIC ANALYSIS OF THE WATER SOURCE, AND MAKING THE PROPER SELECTION OF EQUIPMENT BASED ON THIS DATA.

AVAILABILITY OF WATER

THE WATER CYCLE

Water can come from several different sources; groundwater, surface water, rain harvesting, or water storage. Some growers may have easy access to quite a few of these resources, while others have trouble getting sufficient water from one of them. The availability of water depends on the location of the field. In addition, the crop that is being grown and the irrigation method used has an effect on the amount of water needed. It is important for all growers to manage their water source to ensure a successful growing season.

GROUNDWATER

Groundwater may be the most reliable water source on earth and its correct management is vital to ensure its supply for the future. Unfortunately, groundwater measurements are fairly complicated, because its flow is hidden. So if the availability of groundwater is not watched carefully then problems such as supply limitations, pump wear, clogging, and over-pumping may occur.

Over-pumping is when more water is being pumped from a well than the well can efficiently supply, meaning the groundwater cannot be replenished. The pump will dry-run and be damaged, if the pump keeps running. If the pump pulls in sand, this can also damage the pump. Using an in-well sand separator prior to the pump unit will remove unwanted sand. However, the best way for the farmer to try to prevent damage to the water supply and pump is to analyze how much water the well can provide.

Water availability on Earth:

- **3%** is fresh or **1%** available for use
- **70%** is held in the ice caps
- **30%** is available as groundwater or from lakes and streams

When selecting the correct pump for pumping groundwater, the pH of the water, the temperature of the water, the minerals in the water and the salinity are important. The length of the irrigation period and the total run time of the pump must be considered to provide enough time for service and repairs, also if additional irrigation run times are required due to extremely hot temperatures. If electrical use rates are based on when the pump is operating, an important consideration is to select the pump size so that water delivery can be made in off peak operating times.

The type of irrigation system being used should be taken into account when selecting a pump due to different operating pressures that may be required from, say, a sprinkler system compared to a drip irrigation system. An incorrect selection can lead to inadequate water and/or pressure. The water quality may also cause increased wear on the impellers and other pump components.

It is possible that the availability of water in a well is constantly changing. If that is the case, a VFD should be used; they are designed to react to unsteady water flow and safeguard the pump from dry-running. Similarly, if the water table drops during the irrigation season a VFD may be used to ensure the flow and pressure required for the irrigation system. The pump and motor selection must be made for the maximum drawdown level to ensure the proper water and pressure requirements.

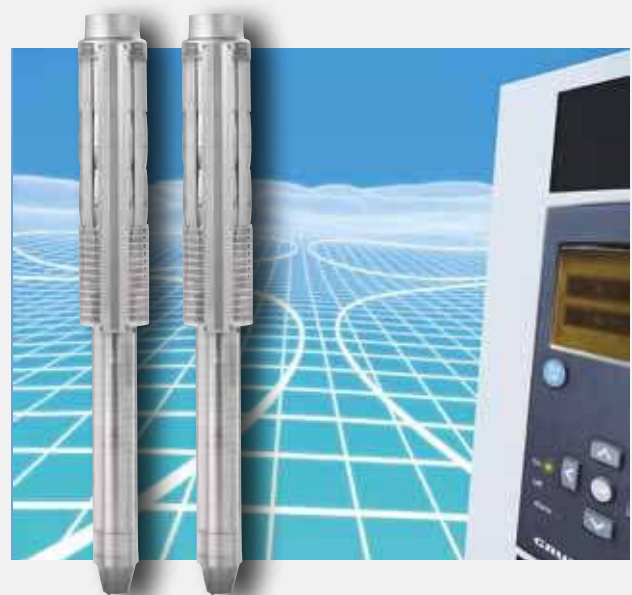

In some cases a farmer may know that if he pumps water straight from the well, he will not have enough water. In that case a reservoir can be built to store the water and pump from this surface supply when required. Water is steadily pumped into a reservoir for longer time periods than it is pumped out while it is pumped out of the reservoir at a faster rate than it is pumped in. The amount of water in the reservoir therefore balances out and can provide a sufficient supply of water for the farmer.

This may be done for frost protection systems where a large quantity of water may be required. However, surface storage of water may lead to the need for treatment, due to algae or other organic materials that find their way into the reservoir. Once water is placed into a reservoir it must be treated as surface water.

SURFACE WATER

Surface water is the second most common source of fresh-water. It comes in many different forms, from lakes, springs, rivers, ditches, streams, and so on. Water can easily be pumped from any surface water location. Nevertheless, there are some factors that need to be considered in order to design an efficient surface water pumping system.

The first thing that one should realise is that if a public surface water source is being used, several users will be pumping from it, and the water level can be significantly lower during dry seasons. In order to ensure an adequate amount of water and to prevent dry-running a pump, a water storage facility should be created.

If the water source is prone to flooding, submersible pumps should be used; dry motor pumps will be damaged beyond repair if they become submerged in water. If a pump is in an area where it may be stolen, it should be protected with a fence or structure to prevent theft or at least make it difficult to steal.

Another factor to consider when designing a surface water pumping system is the water quality. Surface water can carry a substantial amount of mud, silt, and other particles during the rainy and snow-melting season. It is important to construct a settling canal before the pump suction to prevent these particles from entering the pumping system. The canal needs to be at least twenty feet long, and its flow velocity should be no more than 0.05 feet per second when water is being pumped. The particles that settle in the canal need to be removed before every irrigation season so that it can function efficiently. Organism growth in the canal may also affect its performance. The canal should therefore be covered so that sunlight will not stimulate organic growth. The water can also be treated or pre-screened at the intake of the pump with self-cleaning screens or a series of screens to prevent trash and other organic materials from entering the pump and interfering with the operation of the pump.

RAINWATER HARVESTING

When groundwater and surface water is not available or does not provide enough water, artificial reservoirs can be created to bring an ample amount of water to a farm. Two types of man-made reservoirs are rainwater harvesting systems and water storage systems. This option is of course limited in many dry climates where there may not be sufficient rainfall to make this practical. It can however be another source to supplement surface or groundwater supply.

Rainwater can be harvested and stored for future use. Surfaces such as roofs, roads, and paved areas are used to collect the water, and it is then stored in tanks. In order to design a sufficient rainwater harvest system, the demand of water,

average amount of rainfall, and size of storage tanks have to be considered. This system alone usually does not capture enough water to perform all irrigation applications, but it has the ability to carry out most. Treatment of the water during storage may be required as runoff from roofs and other structures may create water quality issues.

WATER STORAGE

A water storage system can either be built as an above ground, open-air basin, or as an underground water tank. These two different types of water storage systems perform the same function, holding water that will be used during peak demand periods, because the main water source cannot meet the peak demand for water. The system that is above ground is less expensive to build or remove. However, water can evaporate, which may lead to a build-up of salt. Since it is above ground, algae and moss are more prone to grow, the basin takes up productive space, and there is the risk of drowning when working in or around the basin. Underground tanks do not pose the problems that open-air basins do. However, they are more expensive to build and remove.

For both types of water storage systems, parallel operating boosters should be used for the distribution pump system. They offer several benefits, including smaller motor sizes, starting amp reduction, and water hammer reduction.

A water bank is a further type of water storage. This involves pumping water down a well in one place to replenish the aquifer, thereby storing it. The water is then drawn up again when needed.

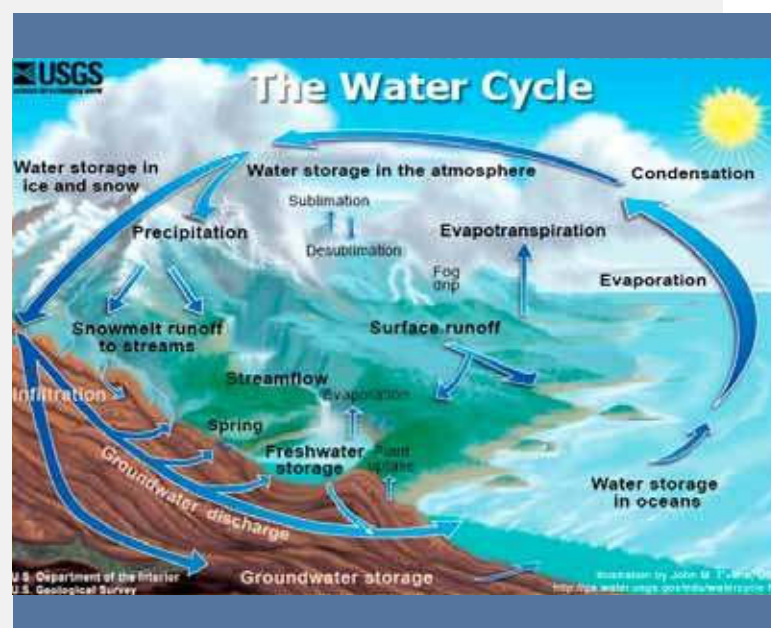

SOIL TYPES	14
INFILTRATION RATE	15
WATER QUALITY AND TREATMENT	16
PLANT RELATIONSHIPS	17
OTHER WATER ISSUES	17



02

SOIL-WATER-PLANT RELATIONSHIPS

THE GROWTH OF A CROP DOES NOT SOLELY DEPEND ON ITS WATERING SCHEDULE. THERE IS AN INTRICATE RELATIONSHIP BETWEEN THE SOIL, WATER, AND CROP THAT HAS A DIRECT EFFECT ON THE CROP'S DEVELOPMENT.

A CROP IS DEPENDENT ON ITS SOIL AND WATER IN ORDER TO GROW WELL.

SOIL-WATER-PLANT RELATIONSHIPS

SOIL TYPES

Soil is formed by the interaction of plants, animals, climactic factors and weathered rock. It consists of mineral particles, decaying organic matter, water, air and living organisms. About half of soil is solely pore space; this is the pockets of air that allow roots to move and water to infiltrate. The other half of soil is made up of mineral and organic matter. Organic matter, however, only takes up between one and four percent of the soil's substance.

The majority of soil is a combination of clay, silt, and sand. Since these three elements play such a vital role in the breakdown of soil, soil classifications are determined based on how much of each element is in the soil.

Each of these particles is unique. Sand is the smallest soil particle that can be seen with the naked eye. Because it is loose and single grained, it feels gritty when it is dry or wet. If a handful of sand is squeezed when it is dry, it will crumble as soon as pressure is released. If a handful of sand is squeezed when it is wet, it will form a cast. However, the cast will crumble the instant it is touched. Silt and clay particles are too fine to be

seen with the naked eye. Silt feels smooth and floury when it is dry and greasy when it gets wet. Clay is very hard when it is dry and sticky and plastic when it is wet, usually forming extremely hard blocks or prisms when it dries. Clay exhibits properties of both cohesion and adhesion. When these three particles are combined, their characteristics are mixed to produce unique features.

These three elements combine into eight soil types. Along with the different types of soil, there are various soil structures as well. The illustration shows how to identify soil types from the soil texture, and estimate the soil moisture from the look and feel of a soil sample.

INFILTRATION RATE

The textures of the soil dictate several different aspects of the soil in relation to water. The time it takes for soil to accept water, how much water the root zone reservoir will hold, the rate that water moves through the soil, and how much water is available to the plant is all determined by the type of soil. When soil first becomes wet, its infiltration rate is high, and then it lowers in a



Dominant texture	Fine Sand and Loamy Fine Sand	Sandy Loam and Fine Loamy Sand	Sandy Clay Loam and Clay	Clay, Clay Loam or Silty Clay Loam
Available Water Capacity (mm/meter)	50-100	108-142	123-175	133-200
Available Soil Moisture	Soil Moisture Deficit in meter/meter when the feel and appearance of the soil is as described.			
0% to 25%	Dry, will hold together if not disturbed. Loose sand grains on fingers. 100-58	Dry, forms a very weak ball. Aggregated soil grains break from ball. 142-92	Dry, soil aggregations break away easily, no moisture staining on fingers. 175-117	Dry, soil aggregations separate easily, hard clods crumble under pressure. 200-133
25% to 50%	Slightly moist, forms weak ball with well-defined finger marks. Light coating of loose and aggregated sand grains on fingers. 58-42	Slightly moist, forms a weak ball with defined finger marks, few aggregated soil grains break away. Darkened color, very light water staining. 92-67	Slightly moist, forms a weak ball with rough surfaces, darkened color, and moisture staining on fingers. 117-75	Slightly moist to moist, forms a weak ball. Very few soil aggregations break away, no water stains. Clods flatten under pressure. 133-92
50% to 75%	Moist, forms a weak ball. Loose and aggregated sand grains remain on fingers, darkened water staining. 42-17	Moist, forms a ball with very few aggregated soil grains breaking away. Light water staining, darkened color. 67-33	Moist, forms firm ball with well defined finger marks, irregular soil/water coating on fingers. Darkened color and pliable. 75-42	Moist, forms smooth ball with defined finger marks, little or no granules remain on fingers. Pliable, ribbons between thumb and forefinger. 92-50
75% to 100%	Wet, forms a weak ball, loose and aggregated sand grains form uneven coating on finger. 17-0	Wet, forms ball, free water appears on soil surface when squeezed or shaken. Irregular soil/water coating on fingers. 33-0	Wet, forms soft ball, light to heavy soil/water coating on fingers. Soil may glisten after squeezing or shaking. 42-0	Wet, forms soft ball, soil may glisten following squeezing or shaking. Light to heavy soil/water coating on fingers, easily ribbons. 50-0
Field Capacity (100%)	Wet, forms a weak ball. Free water glistens briefly on surface when shaken. Wet outline on hand after squeezing. 0-0	Wet, forms soft ball, free water appears briefly on soil surface when squeezed or shaken. Irregular soil/water coating on fingers. 0-0	Wet, forms soft soil pat with water glistening on surface after squeezing or shaking. Thick soil coating on fingers. 0-0	Wet, forms very soft soil pat. Thick soil/water coating on fingers. Soil glistens, slick and sticky, will not ribbon. 0-0

Estimating soil moisture depletion from the look and feel of a soil sample (from USDA, NRCS Booklet "Estimating Soil Moisture by Feel and Appearance").

logarithmic pattern. A coarse sandy soil can take in more water per hour than a clay soil. However, fine textured soil does have more pore space than coarse textured soil, so it can hold more water; the sizes of the pores themselves are smaller in finer soils but there are more pores overall.

Fine textured soils can therefore store more water per meter depth than coarse soils. Soils that contain a lot of sand only have about 42 mm to 83 mm of available water per meter depth, whereas soil that is abundant in silt can have up to 200 mm of water per meter depth.

Infiltration rate is also dependent on the watering pattern, the amount of calcium in the soil, the amount of salt in the soil, tillage, the amount of microorganisms in the soil, and the amount of organic matter in the soil. If water is applied to the soil surface faster than the permeability and infiltration rate of the soil, the soil's surface is susceptible to sealing. This decreases the infiltration rate of the soil, and it can cause

ponding. Ponding leads to more problems, such as runoff, fertiliser and pesticide loss, erosion, and an increased possibility for disease.

Another problem that may occur with a soil watering pattern is disturbance in the soil surface structure. If sprinkler irrigation is applied too forcefully (large droplet sizes and high application rates), it will break the surface structure. Also, excess applied irrigation water has a tendency of forming a water table in the root zone of the soil. Water tables bring up salt layers that can harm roots.

Infiltration rates are improved with calcium, organic matter and microorganisms. Water application rates and the total amount of water applied should not be more than the infiltration rate of the soil types and the water holding capacity of the soil to the depth of irrigation desired. A balance of solids, water and air should be present in the soil.



Saturated	Field capacity	Wilting point	
Saturated soil	Solids	Water	
Field capacity	Solids	Water	Air
Wilting	Solids	Water	Air

The field capacity is the amount of water the soil will hold. Too much water, and the soil is saturated; too little, and the plants quickly approach wilting point.

The soil is the water storage area from where the roots take up water. It acts like a sponge and is similarly limited as to how much water it can hold. Once the soil is at field capacity, water runs through it like a sponge that can no longer hold any additional water.

Different types of soils hold different amounts of water and therefore a balance between the solids, water and air in the soil needs to be maintained. Fundamentally, this balance is about 50% solids, 25% water and 25% air. The key is to irrigate up to field capacity and avoid saturation where you have no air. And you want to avoid getting to a wilting point where the roots can no longer remove water from the soil surface. The length of time between irrigations and the amount that can be applied is based on the soil type and the depth of the plant roots.

Tillage can improve the infiltration rate of soil by breaking up the sealed soil. However, if a field is tilled too often with the same repeated pattern, plow pans can form underneath the surface of the soil. The soil that makes up the plow pans is pressed together harder than the soil on top and the overall infiltration rate of the soil is reduced.

Finally, too much salt in soil poses a threat to plants. The only way that plants are able to pull water out of soil is by having a higher solute concentration than the concentration of salts in the water, because the water moves through the plant roots

due to osmotic pressure. Too much salt will slow down and can maybe even stop the intake of water through the plant's roots. One other thing that may be a concern when dealing with infiltration rates is the amount of fragments on top of a field. Things such as leaves and weeds may block the pores of the soil, and water will not be able to enter the soil efficiently.

Levels of moisture contents of a field depend on the amount of water that has infiltrated in the soil. When a soil is too dry, plants begin to wilt. If they do not get water over a period of time, they enter permanent wilting and cannot be brought back to health.

An experienced farmer can determine the soil's moisture level by the feel of the soil, and devices are available that can measure the soil moisture.

When soil moisture sensors are used, they need to be placed in a field strategically. If they are placed in an unusually wet or dry area of the field, it will give an inaccurate reading. This can lead to either the overwatering or under watering of a field.

WATER QUALITY AND TREATMENT

Irrigation water usually comes from a stream, lake, river, canal, or groundwater well. It is very likely that the quality of water being pumped in is not very good, because natural water sources are susceptible to dirt, animal waste, and other fragments. Water can have other problems, such as an irregular pH level. Test the water that is to be used to irrigate your crops and treat the water as required to reduce any water quality issues, so your crops are provided with the quality of water needed for optimum growth.

These water issues need to be dealt with before the water is pumped onto a field. Water can be treated by means of filtration, pH control, and chemigation/fertigation. Chemigation and fertigation is an increasingly important component in an irrigation system, not least because of environmental issues and is covered in Chapter 7. Each water treatment system is specific to the needs of a field and/or the crop requirements.

SOIL MOISTURE MEASURING DEVICES

- Granular Matrix Sensors:**
Measure the electric resistance or capacitance of the sensor that is in contact with the soil.
- Electric Resistance Blocks:**
Measure the resistance or conductivity between the blocks that are buried in the ground.
- Tensiometers:**
Measure the vacuum that plant roots exert on the soil in contact with the device
Other types are **Time Domain Reflectometry, Frequency Domain Reflectometry, or Neutron Probes**



PLANT RELATIONSHIPS

With all this discussion about water, it is natural to wonder why water is so important to a crop, and how crops develop. In order to understand this, it is necessary to know how a plant works. Plants absorb water through their root hairs, by means of osmosis. Root hairs grow according to their environmental conditions and move through pore space to absorb water. Water is constantly being absorbed by a plant, to satisfy the deficit of water that evaporates off of the plant's leaves. Water normally moves from the soil through the semipermeable walls of the plant root's cells. It then goes up the xylem tissues to the leaves. It is released to the atmosphere through the leaf cells called stomata. When the stomata discharge water, they absorb CO₂ at the same time. The reason why all of this takes place is so the plant can perform photosynthesis, which is the process that plants go through to make their energy.

Transpiration:

The rate that water evaporates off the plant's leaves

Evaporation:

The rate that water evaporates from the soil

Evapotranspiration:

The movement of water from plant leaves and soil

If the roots are not bringing in enough water and the plants internal pressure is not adequate, the plants may wilt. Depending on the crop, stress is necessary at certain times, can be tolerated at certain times, or should always be avoided. A farmer should always water his crop according to its water needs and degree of stress.

The rate that water evaporates off of the plant's leaves is called transpiration. This dictates how much water is absorbed from the soil. When this is combined with the rate that water evaporates from the soil, evaporation, a farmer will be able to know how much water he needs for his crops. This movement of water from plant leaves and soil is called evapotranspiration.

Different crops have differing water needs. Some require more water at certain growth stages. Also, some crops can be irrigated by means of deficit irrigation, while others would suffer when that technique is applied. There are a number of plants that have the ability to angle their leaves, to regulate their own transpiration as well. Moreover, a plant's ability to intake water depends on their root zone; roots grow best when soil has sufficient moisture but is not saturated, air is adequate for respi-

ration, and microbial activity is high. Thus, it is important for a farmer to make the field conditions ideal for the crop.

OTHER WATER ISSUES

There are of course environmental issues with irrigation of which every grower should be aware, such as waterlogging, salinisation, deep drainage, and backflow. Waterlogging is caused when too much water enters the root zone, causing plants to shut down and delay growth until some of the water drains. Salinisation can occur when there is a lack of sub-surface drainage; leaching of salt from soil may be restricted, meaning the soil will have too much salt for a plant to grow. Deep drainage is what happens when water drains and moves below the root zone. This brings salt up to the soil in areas where there is a saline level, and it also raises the water table. Backflow occurs when irrigation water and/or chemicals contaminate the water supply. This can be averted with a backflow preventing device that is capable of shutting down the system if any backflow happens. Overall, all of these problems can be avoided if an irrigation schedule satisfactory for the field is followed. Finally, drainage of irrigated fields is almost as important as the irrigation system and application of water.

There is an obvious intricate connection between the soil, water, and plant growth. If the smallest thing is wrong with either soil or water, the crops can suffer tremendously. It is therefore necessary to be tuned in with the way a crop grows and its needs. Equipment, labor, and watering schedules need to be chosen carefully and kept up regularly to ensure a crop gets the care that is needed to produce a plentiful yield.



DEFINING IRRIGATION	20
A BRIEF HISTORY	20
CRITICAL APPLICATIONS – NURSERIES AND GREENHOUSES	21
NON-AGRICULTURAL IRRIGATION	21



03

WHAT IS IRRIGATION ?

THERE ARE SEVERAL DIFFERENT DEFINITIONS FOR THE WORD IRRIGATION; SOME ARE SPECIFIC TO ONE TYPE OF IRRIGATION, AND OTHERS ARE VERY BROAD. THIS BOOK WILL TALK ABOUT ALL TYPE OF IRRIGATION, BUT ITS MAIN FOCUS IS AGRICULTURAL IRRIGATION.

WHAT IS IRRIGATION ?

DEFINING IRRIGATION

In general, irrigation is the application of water to soil. In agriculture, irrigation is the application of water by means of ditches and pipes to plant roots to assist in crop production and sustain plant life. It also plays a role in protecting crops from frost. The purpose of irrigation is to provide water to crop-filled land, and the goal of irrigation is to make land fertile and lush. In agricultural irrigation, the focus is on profitability, meaning a focus on energy optimisation and better use of water resources.

Modern agriculture requires we understand past practices, today's water and energy issues, and developments in pump technology. We must then optimise uniformity, reduce energy use and safeguard water resources.

A BRIEF HISTORY

Agricultural irrigation is an art that is continuously evolving. Practices are always being refined and new methods developed to increase crop yield. Where precisely irrigation first began is in question and some believe that the Sumerians of Mesopotamia invented agricultural irrigation in 8000 BC. Their main water source was the Tigris and Euphrates rivers. The land

near the rivers was too salty to sustain plant life and they built canals from the two rivers to bring water to land that was less salty, allowing them to grow their crops. Others believe that in 5000 BC the Egyptians were the first to irrigate land. They created an irrigation system that stemmed from the Nile River.

The next great irrigation achievement happened about 3000 years ago in the Persian Empire, when the Kareze irrigation system, the earliest form of the aqueduct system, was created. Some of the other farming methods used at that time were Shadoofs, Persian Wheels, and dams. Variations of these methods are still being used today.

In the 1700's the European agricultural revolution took place. People began to experiment with agriculture in order to develop new crop rotations, improve livestock breeding, invent seed drilling, experiment with fertilisers, design new machinery, and introduce new crops. As a result, productivity of the land increased while the need for labor decreased. The amount of food supply grew sufficiently to keep up with the growing population and urbanisation that was taking place at that time.



Shadoof irrigation system

VARIATIONS OF OLD IRRIGATION METHODS ARE STILL BEING USED TODAY

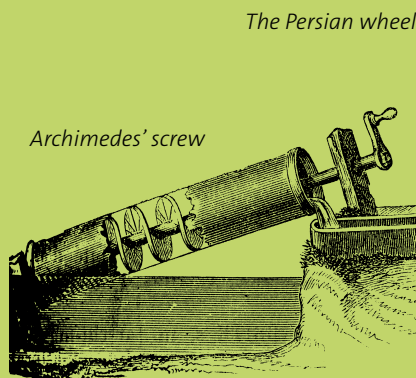

Archimedes' screw

The Persian wheel



Meanwhile, agricultural advancements were taking place in the Americas as well. The colonists were innovative, like the Europeans. They experimented with farming practices, machinery, breeding, and also pesticides.

In the 1890's, the first domestic lawn sprinkler was invented. In 1932, the first impact sprinkler was invented. This sprinkler helped farmers greatly, because their fields could now be watered automatically, underground irrigation systems could be installed, and furrow irrigation could be replaced.

In the late 1960's farmers in the United States realised that drip irrigation could increase crop yield while lowering water usage and it could also adapt flexibly to any layout. Farmers began to practice micro irrigation, which then spread most rapidly in drought-plagued regions.

Early farmers believed that water was an infinite resource and they did not strive to conserve it. Today we know that there is a finite amount of water. This awareness is put to use to optimise uniformity, reduce energy costs, and safeguard water. Farmers of today are constantly striving to make their agricultural practices more efficient.

CRITICAL APPLICATIONS – NURSERIES AND GREENHOUSES

In a highly controlled environment such as a nursery or a greenhouse, all water issues are exponentially magnified and can quickly turn critical. Margins for error are small and risks are great. Therefore the flow, pressure and the uniformity of the irrigation device have to be extremely precise. The quality of water is also very critical.

NON-AGRICULTURAL IRRIGATION

Although our focus in this handbook is agricultural irrigation, landscape and turf irrigation is also an application that draws increasingly on our water resources. The use of water to irrigate lawns and shrubs is substantial, and its application is generally not as efficient as with agricultural irrigation. Golf courses and other recreational or sporting activities are good examples of how non-agricultural applications for irrigation are rapidly increasing.

Even where landscaping uses artificial grass, the water demand increases. Increasingly we see grass being removed and replaced by artificial grass; however water is required to wash down the dust. Water use in manufacturing artificial grass also needs to be taken into consideration.



ACHIEVING AN EFFECTIVE AND EFFICIENT IRRIGATION	24
DISTRIBUTION UNIFORMITY AND IRRIGATION EFFICIENCY	24
RELATIONSHIPS BETWEEN DU AND IE	24
IRRIGATION SCHEDULING	26



044

BASIC IRRIGATION OPERATION

TO IRRIGATE SUCCESSFULLY, THE FARMER NEEDS TO BE CONCERNED WITH WATER DISTRIBUTION UNIFORMITY AND IRRIGATION EFFICIENCY. SINCE THE COST OF ENERGY USED TO RUN IRRIGATION PUMPS IS ONE OF THE HIGHEST SINGLE EXPENSES IN AGRICULTURE, THE FARMER TRIES TO IRRIGATE THE LAND EFFICIENTLY IN ORDER TO SAVE MONEY. THIS CHAPTER HELPS TO UNDERSTAND HOW THIS IS BEST ACHIEVED.

BASIC IRRIGATION OPERATION

ACHIEVING AN EFFECTIVE AND EFFICIENT IRRIGATION

Irrigation is both an art and a science. Research has provided many concepts and methods for measuring the various processes involved in irrigation. However, knowledge of the field and crop, along with the grower's experience in interpreting this science, will remain of utmost importance in achieving effective, efficient irrigations.

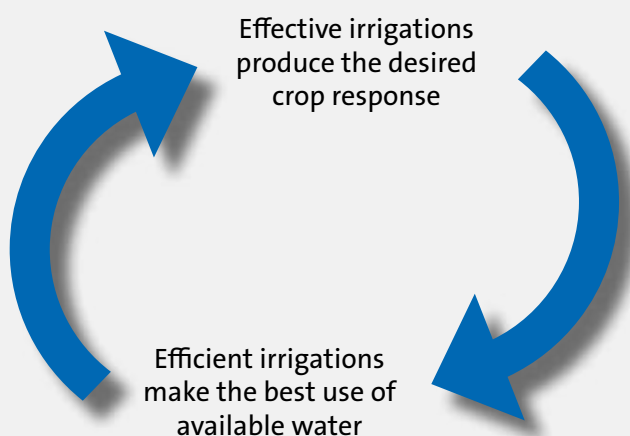

Irrigation efficiency does no good if it is not effective in producing a profitable crop. Effective, efficient irrigation is a result of knowing when to irrigate, how much to irrigate, and how to irrigate.

- **When** – an agronomic decision based on how you want to manipulate your crop.
- **How much** – depends on the soil moisture depletion in the effective root zone. This is the amount of water needed to take the soil moisture reservoir back to field capacity or other desired level.
- **How** – this is not just about knowing how to set a siphon, or connect a sprinkler pump. It is also knowing how to apply water evenly to a field while controlling the total amount applied.

An effective, efficient irrigation produces a profitable crop while making the best use of available water supplies and creating a minimal impact on water quality. In doing so it must also minimize energy use and save money.

DISTRIBUTION UNIFORMITY AND IRRIGATION EFFICIENCY

There are two measures of irrigation performance – distribution uniformity and irrigation efficiency.

Distribution Uniformity (DU) is a measure of how evenly water soaks into the ground across a field during the irrigation.

If eight inches of water soaks into the ground in one part of the field and only four inches into another part of the field, that is poor distribution uniformity. Distribution uniformity is expressed as a percentage between 0 and 100%. Although 100% DU (the same amount of water soaking in throughout the field) is theoretically possible, it is virtually impossible to attain in actual practice.

Irrigation Efficiency (IE) is the ratio of the volume of irrigation water which is beneficially used to the volume of irrigation water applied.

Beneficial uses may include crop evapotranspiration, deep percolation needed for leaching for salt control, crop cooling, and as an aid in certain cultural operations. Differences in specific mathematical definitions of IE are due primarily to the physical boundaries of the measurement (a farm, an irrigation district, an irrigation project, or a watershed) and whether it is for an individual irrigation or an entire season.

Irrigation efficiency is also expressed as a percentage between 0 and 100%. An IE of 100% is not theoretically attainable due to immediate evaporation losses during irrigations. However, it could easily be close to 95% IE if a crop is under-watered. In this case, assuming no deep percolation, all water applied and not immediately evaporated would be used by the crop.

The term irrigation efficiency should not be confused with the term water use efficiency (WUE). WUE is generally a measure of yield per unit water applied.

RELATIONSHIPS BETWEEN DU AND IE

There are two important relationships between DU and IE: deep percolation and under-irrigation. The illustrations below show a profile view of two adjacent sprinklers in a field and the root zone under them. The horizontal, dashed line in the figures depicts the depth of the actual soil water depletion at irrigation.

This is the amount of water that the grower would be trying to soak into the soil to satisfy crop water use requirements. The blue shading depicts the actual depth of water infiltrated during the irrigation.

Deep percolation is indicated whenever the actual depth of irrigation (blue water level) is below the soil water depletion line (the horizontal, dashed line). Conversely, under-irrigation is indicated whenever the actual depth of irrigation is above the soil water deficit line.

These two illustrations demonstrate the first relationship, that there must be good distribution uniformity before there can be good irrigation efficiency if the crop is to be sufficiently watered.

In the illustration to the left, the farmer has irrigated to sufficiently water the entire field. The poor DU, indicated by the

uneven blue water level, has resulted in excessive deep percolation, meaning that much more water is infiltrated between the sprinklers than next to the sprinklers. It is important that leaching must be uniform across the field over a number of years to prevent areas of excessive salt accumulation.

To the right, the farmer has acted to prevent excessive deep percolation by shortening set times. Now part of the field remains under-irrigated. Under-irrigation usually results in high irrigation efficiency because most water applied is stored in the root zone, available for plant use. However, under-irrigation is usually not an effective way of growing since the resulting water stress on the crop in some parts of the field will usually decrease yields. Also, there is a need for some deep percolation for leaching to maintain a salt balance.

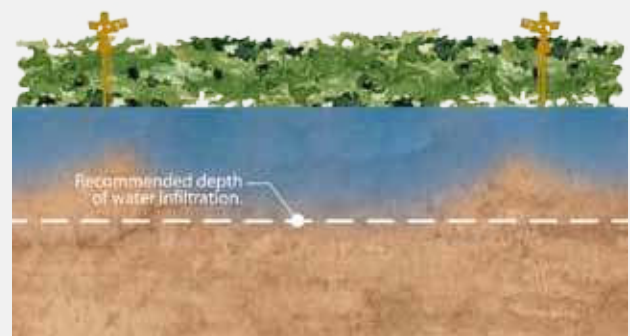
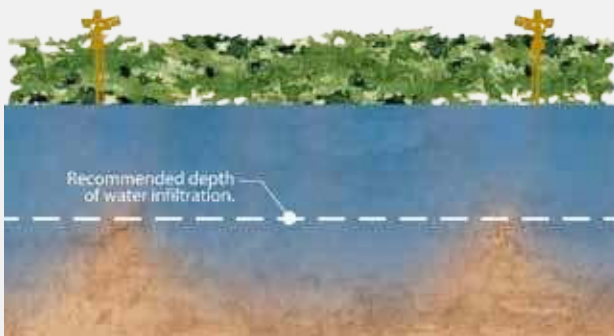

KEY CONCEPTS FOR PLANNING AN IRRIGATION

Please see the Glossary for further definitions.

Application rate (AR): the equivalent depth of water applied to a given area per hour by the system, usually measured in mm/hour.

Daily crop water use (evapotranspiration – ET): the net amount of water extracted from the soil daily by the crop and surface evaporation from the soil.

Distribution uniformity (DU): a measure of how evenly water is applied across the field during irrigation.

Effective root zone: the depth of soil in which you are actively managing the crop.

Field capacity: the maximum amount of water the soil will hold.

Frequency: how often you irrigate: high frequency vs. low frequency.

Irrigation efficiency (IE): a measure of how much water that is pumped and applied to the field is beneficially used.

Net water needed versus gross water applied: net water is what you need to replace in the field. Gross water is how much you have to pump in order to accomplish this goal.

Soil moisture depletions (SMD): the net amount of water that you need to replace in the root zone of the crop.

Soil probe: a long piece of 9.525 mm steel bar, usually tipped by a ball bearing, with a handle. The probe is pressed into wetted soil to judge how deep water has penetrated. It can be used during an irrigation to indicate when enough water has soaked into the ground. It can also be used to judge the uniformity of irrigation. If 2-3 days after an irrigation the probe can be pushed into the soil to a depth of 1.2 meters at the top of a furrow, and only to 0.61 meters at the bottom of the same furrow, this is an indication of poor distribution uniformity.

These two illustrations demonstrate the second relationship, that good distribution uniformity is no guarantee of good irrigation efficiency.

The illustration to **the left** depicts a good irrigation. There was a high DU as indicated by the flatter blue water level. Approximately the right amount of water was applied. There is little deep percolation (enough for salt control) and the entire field is wetted sufficiently. It is assumed that surface runoff was minimal or collected for reuse.

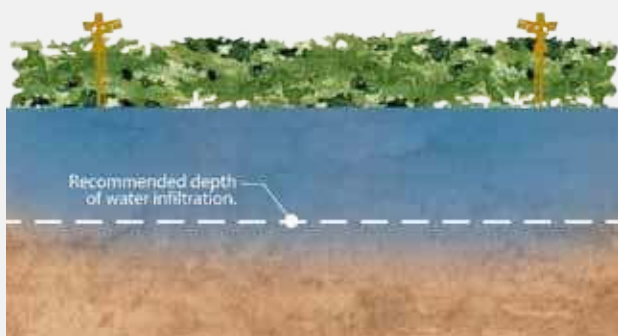

To **the right** an irrigation is shown with the same high DU as in the first illustration. However, twice as much water as needed was applied, resulting in low irrigation efficiency. A practical example of this situation is the farmer who is using a well-designed and maintained micro-irrigation system. The hardware provides good DU and the potential for high IE. However, if the farmer runs the system twice as long as necessary, that potential is not realised.



Improved irrigation system hardware or management may result in higher distribution uniformity and improve the potential for higher irrigation efficiency. It then follows that distribution uniformity is the first concern when improving irrigation system performance. However, actually achieving high irrigation efficiency ultimately depends on two factors - knowing how much water is needed and controlling the amount of water applied to match that need.

IRRIGATION SCHEDULING

Wherever data is being collected or provided in the field, the evapotranspiration rate at that particular piece of ground can be determined, meaning the amount of water needed to replenish at the root zone can be calculated. This data is obtained from weather stations in the field, from weather data providers, soil moisture sensors installed in fields for soil moisture levels at different depths, pH monitoring, soil temperature, solar radiation, information for insect and fungus control (humidity levels), and rainfall, all based on the crop being grown.

This information is available to farmers today, and the farmers can then define when and how much to irrigate. We are increasingly seeing the automation of this process and/or the collection of the data to be reviewed by the irrigator or farmer. The final decision always remains with the farmer and very few, if any, systems are fully automated due to the high cost of failure. Smart controllers are still new to the irrigation industry. Their use will increase as farmers learn how to use them as a tool, as is the case in the landscape and turf industry.

The landscape and turf industry has less of a financial loss if the plants and turf are not irrigated properly, whereas the farmer has a much greater chance of loss if crops are not properly irrigated.

Where the irrigation scheduling of microirrigation on crops such as strawberries on soils with very little water holding capacity, such as sandy soils, it may be necessary for the farmer to calculate the crop ET hourly.

Scheduling irrigation is not only dependent on the above. Power is generally less expensive off-peak, meaning that the irrigation system and pumping system may be designed and built to deliver the desired water during off peak hours. Flow may be higher than necessary for the 12 hours (for example) that power costs less. Irrigation scheduling must be done to apply water in the limited time frame to meet the least energy costs – as is already the case in municipal water supply and wastewater handling – and this is now becoming more commonplace for farmers.



WHY FLOOD IRRIGATE	30
TYPES OF FLOOD IRRIGATION	31
COMPONENTS & EQUIPMENT	31



055

TRADITIONAL FLOOD IRRIGATION

METHODS AND EQUIPMENT

OF THE TWO MAIN TYPES OF IRRIGATION METHODS, FLOOD IRRIGATION – OR SURFACE IRRIGATION – IS THE OLDEST AND IS STILL THE MOST COMMON FORM OF IRRIGATION IN MANY PARTS OF THE WORLD. FLOOD IRRIGATION HAS UNIQUE PROCEDURES THAT NEED TO BE FOLLOWED IN ORDER TO MAINTAIN THE SYSTEM WHILE IT IS BEING USED AND TO PRESERVE THE SYSTEM FOR THE NEXT CULTIVATION SEASON.

TRADITIONAL FLOOD IRRIGATION



WHY FLOOD IRRIGATE

Flood irrigation sees water delivered to the field by means of a ditch or pipes. The water is then released to flow freely over the land and through the crops. About half of the water applied to the field actually irrigates the crops, and the other half is lost through evaporation, runoff, transpiration, weeds, and infiltration of uncultivated areas. The efficiency of flood irrigation is therefore not very high and because of this, it is primarily used in areas where there is an abundance of water. It is also used in areas where the farmer cannot afford a pressurised irrigation system and this is the only means they have to irrigate and grow the required crops.

There are several issues that farmers deal with when performing flood irrigation. Some of the more important concerns are distribution uniformity, field flooding and environmental impacts on crops. This type of irrigation naturally has low distribution uniformity, because all of the water is applied at one section of the field. The top of the field will naturally have more time to absorb water than the bottom of the field.

THE FLOOD IRRIGATION PROCESS CONSISTS OF FOUR MAIN TIME INTERVALS

Phase 1 – the advance phase: The length of time it takes for water to be applied to the top end of a field and flow over the field length.

Phase 2 – the storage phase: The time between the end of the advance phase and the shutoff of the inter-flow.

Phase 3 – the depletion phase: The short period after shutoff, while the field is still submerged in water.

Phase 4 – the recession phase: The period where the waterfront is retreating towards the downstream end of the field.

Furthermore, if a field is flooded with all of the necessary water at once, the farmer does not take advantage of the capillary movement of water through soil and the amount of water infiltration into the soil is less than it could be. This means the farmer may face issues like runoff, which can lead to further more damaging issues. Certain watering patterns and overwatering may cause waterlogging, deep drainage and salinisation, all of which can severely damage a crop.

However, if the soils of a field are high in salts and the water has little to no salts, flood irrigation can be used to remove salts with deep percolation and/or with drainage tiles

TYPES OF FLOOD IRRIGATION

There are different types of flood irrigation methods. To improve the uniformity and efficient watering of a field undergoing flood irrigation, the farmer can practice surge flooding. Some believe that this technique is highly effective, while others say that there is little evidence that surge flooding significantly improves wetting patterns. It has been shown that this technique works better on certain soil types than it does on others; it may not be an appropriate method to use on all flood irrigated fields. However, it is an option for farmers who have trouble with horizontal water movement or other water issues that pose a threat to crops.

Surge flooding is the practice of pulsing the water on and off at certain time intervals, instead of applying all of the water at once. These wet and dry cycles produce surface consolidation. This means that the infiltration rates at the locations where the field gets the wettest is reduced, while the infiltration rates where the field is the driest stays the same. Overall, the infiltration rate of the field as a whole has a higher uniformity. This can also decrease the amount of water runoff from a field.

Basin irrigation is used in small areas of land with level surfaces surrounded by earth banks. Water is quickly applied to the entire basin, and is then left there to infiltrate. The water drainage system is usually set up so that the extra water and runoff from one basin can be diverted to the next basin. A basin's shape normally follows the natural contours of the land, however they can be laser leveled. This type of flood irrigation is mainly used to irrigate rice and wheat crops.

Furrow irrigation is the practice of creating parallel channels along the field length in the direction of the slope of the field. Water is supplied to the field by gated pipe, siphon and head ditch or bankless systems, and it is applied to the top of each furrow. It is then left to move freely down the field. The speed that the water moves down the field is determined by several factors; slope, surface roughness, furrow shape, and soil infiltration rate among them. The space between each furrow depends on the type of crop being grown, but it usually ranges

The efficiency of flood irrigation is not very high and it is primarily used in areas where there is an abundance of water.

between 0.61 meter and 2.13 meter. Crops are planted on the ridge between each furrow. This form of flood irrigation works best for broad-acre row crops and horticultural industries. Many of the older vineyards and tree fruits are still using flood irrigation and the majority of all new plantings are irrigated with some form of micro irrigations.

Another type of flood irrigation is known as either Bay irrigation or Border Strip irrigation. This method is considered a hybrid of basin and furrow irrigation, because the borders of the irrigated strips are longer and narrower than that of basin irrigation. In Border Strip irrigation, low ridges are aligned lengthwise with the field; spaced somewhere between 6 meters and 30 meters apart. Water is applied to the top of the bay, and flows down as permitted by gravity. This type of irrigation is mainly used for pasture dairy production irrigation.

COMPONENTS & EQUIPMENT

The water source for flood irrigation can be either gravitational or with pumps to raise water from surface water sources or deep wells to canals or basins. From there, the water is siphoned out to the field. Sub-mains and risers from the mains – often as aluminum pipes with gates – ensure the water is led to the furrows.

Flood irrigation may not necessarily have dosing equipment in the system. Fertilisers and chemicals are often applied directly from a tank with a gate valve out in the field. Dosing is estimated and controlled by manual opening and closing of the gate valve. If noxious gases are used, these will be from a closed tank and the gas is fed directly into the water from the siphon pipe. Dosing and disinfection, and the application of fertiliser and chemicals in this way is imprecise and does not ensure even coverage of the crop.

<hr/> SPRINKLER SYSTEMS	34
<hr/> DRIP IRRIGATION	36
<hr/> COMPONENTS FOR PRESSURISED IRRIGATION	38
<hr/> TYPES OF FILTRATION EQUIPMENT	41



066



MODERN PRESSURISED IRRIGATION

METHODS AND EQUIPMENT

PERFECT IRRIGATION MEANS THAT PLANTS GET THE WATER THEY NEED EVERY DAY, WHEN THEY NEED IT. THIS SCENARIO IS RARELY THE CASE; THERE ARE SIMPLY TOO MANY VARIABLES THAT HAVE TO BE BUILT INTO THE IRRIGATION DESIGN. HOWEVER, WE HAVE MEANS AND METHODS TO CONTINUALLY OPTIMISE THE IRRIGATION.

MODERN PRESSURISED IRRIGATION – METHODS AND EQUIPMENT



A pressurised irrigation system consists of a water source, a pump to pressurise the water, a pipe system to distribute the water from the pump, and a means of distributing the water to the crop. Means of distributing the water in the field are primarily sprinkler irrigation, where sprinklers spray the water across the ground, and drip irrigation, where water and nutrients are applied directly to the root zone.

SPRINKLER SYSTEMS

Sprinkler systems effectively produce artificial rain. Sprinklers can provide a uniform application, with the correct sprinkler and nozzle size for accuracy, adequate pressure flow, correct mounting on a riser at the correct height, and if they are spaced evenly so that the degree of overlap is uniform. Weather conditions must be considered when installing these systems, because wind gusts can disturb the uniformity of a system.

These systems are normally designed to apply water at a lower rate than the soil's infiltration rate, so that the amount of water infiltrated at any point on the field depends on the application rather than the soil infiltration rate. They can be used on a wide variety of applications, including agriculture and landscaping. There are different categories of sprinkler systems, and many types of systems within each category.

Major categories of sprinkler irrigation are traveling irrigators, where a sprinkler, or a set of sprinklers, is attached to equipment that can be moved around, and fixed sprinklers, which are favored where traveling sprinkler systems would be hard to maneuver in irregular shaped fields.

FIXED SPRINKLER SYSTEMS

Fixed sprinklers are mounted on pipes that are either above or below ground. Some types are:

HAND MOVE sprinkler systems consist of 6 to 12 meters long sections of aluminum pipe, with quick coupling connections at each joint. Sprinklers are installed on pipe risers, which are then connected to the pipe couplings on each of the lateral pipelines. These lateral lines are assembled and operated in one area, and are then disassembled and moved to another area to apply water. The sprinkler systems themselves are low cost, but they do require a large amount of labor. They can be used on just about any crop, however they can be hard to move if they are used on land with sticky soil.

Solid set (or Permanent) systems are similar to hand move except the field has been installed with all the pipe and fittings and no moving of anything is required to irrigate. Only valves need to be turned on or off for each zone.



POP UP SPRINKLERS are typically used on turf areas but not sod farms, are installed at ground level with all the plumbing buried beneath the ground level and water pressure brings them up to irrigate. These systems normally have a permanent, buried water supply line, meaning the sprinklers cannot be moved. This type of irrigation system is designed to make sure that every inch of ground receives a minimum amount of water. This type of sprinkler system is not ideal for growing crops.

TRAVELING SPRINKLER SYSTEMS

SIDE ROLL systems are a type of traveling irrigator where the structure is a mechanized variation of the hand move system. A lateral pipeline that has sprinklers connected to it is mounted on wheels, with the pipeline acting as the axle. Wheel size is chosen to ensure the axle clears the crop as it moves through the field. A drive system, located near the center of the lateral pipeline, moves the system from one position to the next.

TRAVELING GUN systems, also known as hose reel irrigators, involve a high volume sprinkler gun mounted onto a trailer that typically covers a large area. This system can easily be hauled into a field, and moved around from location to location. Water is delivered to the system by a hose hooked up to a water supply. Traveling gun systems usually produce large droplets and high application rates, so they are best suited for coarse soils with high intake rates.

CENTER PIVOT systems are lateral pipelines with sprinklers, which rotate

around a central point. They are constructed in segments, each with a wheel at the end and can run off of any type of water source, with water pumped through the center of the pivot from where it flows through the pipes and out of the sprinklers. Each sprinkler has a pressure regulator right before the sprinkler head, and the sprinkler nozzles are smaller near the center of the pivot and get bigger further out on the pivot. The pivot's sprinkler system is designed this way because the end of the pivot covers more ground than the inner parts of the pivot. An end gun at the end of the pivot turns on when the pivot reaches



a corner to irrigate the land that the pivot does not cover. Pivots may contain an arm that swings out to irrigate corners of a field, instead of end guns. Most center pivots require dismantling to be transferred to another location. This system is known for its great efficiency in water application and the high initial cost is usually balanced out by its low cost in labor.

LINEAR MOVE systems are similar to the center pivot, because they are both made up of series of aluminum pipe towers with sprinklers attached; however both ends of the linear move system migrate along the field. This system is designed to irrigate a rectangular field that does not contain any large trees or obstructions. Water is supplied to the linear move system by hose. One of the greatest problems and costs of the linear move system is that it starts at one end of the field and ends at the other, meaning the return run along the field is without spraying water, adding to the energy expense of irrigation.



DRIP IRRIGATION

Drip irrigation is arguably the most efficient form of irrigation, because there is minimal runoff and evaporation; water and nutrients are applied directly to the root zone, and the design of the system is with tubing either buried underground or lying flat near the plants. Emitters evenly spaced on the tubing ensure that water is distributed uniformly to each plant. The emission device, its flow rate and spacing, depends on the crop being grown and the soil texture.

Drip irrigation is known for its flexibility. Each system is custom designed to fit the needs of the crop and the land, in order to maintain optimum moisture at the plant root zone. Since they apply water directly to a plant's roots, a minimal amount of water is wasted, and drip systems can operate at up to 95% uniformity. These systems are therefore perfect for drought-plagued areas. Drip irrigation systems may be convenient during harvest, because they can run while crops are being picked. Moreover, these systems can last as long as twenty years, if they are properly maintained.

Unfortunately, these systems do require a lot of maintenance; they can be damaged easily as well. Since drip emitters are so small, they are susceptible to clogging, even at mineral concentrations as low as 0.1 ppm, and it is necessary to analyze and treat the water that is going into the system. Identifying emitters that are clogged can also prove difficult, because they are usually buried underground.

These systems should be flushed periodically, their filters need to be cleaned frequently, and pressure gauges should be checked regularly to make sure the system is running correctly and there is no buildup. The drip tape is susceptible to damage from for example installation equipment, tillage equipment, insects, birds, rodents, excessive pressure, and direct sunlight.

Types of punctured emitters

NON PRESSURE COMPENSATING (NON-PC) EMITTERS have a maximum pressure variation of approximately 0.69 bars or 7 meters of elevation change. Large changes in discharge rates. Non-PC drippers should be used on fields with small variations in elevation.

Laminar flow (Flag emitters) work well on very low-pressure systems, such as gravity-flow drip systems, where the water follows a short path before it is emitted. Inexpensive, they work well, although with a tendency of clogging up. The emitter can be taken apart and cleaned. Typically used on landscape residential irrigation systems.



Turbulent-Flow emitters run water through a path with sharp turns and obstacles before the water is released. With a shorter length and larger diameter, they are less susceptible to clogging.

Vortex emitters run water through a little whirlpool to reduce its flow and pressure. Most emitters have a small inlet and outlet hole, which can lead to clogging.



PRESSURE COMPENSATING (PC) EMITTERS deliver the same amount of water over a wide range of pressures.



Pressures can range from 1-3.44 bars or 24.4 meters of elevation change. PC drippers should be used on fields with large variations in elevation.

Drip irrigation is suitable for all crops, although it is costly to install for closely spaced crops and is therefore not the ideal irrigation system for all fields. As noted, the different types of drip emitters that can be used to regulate the flow of water are classified as no pressure compensation (non-PC) or pressure compensating (PC) emitters. The emitters can be on-line, which means they are held on to the tubing with typically a barb, or in-line, meaning they have been inserted into the tubing as during manufacture.

Water can also be applied from a drip system using either micro sprinklers or micro sprays. These operate at a low pressure, produce small to medium sized droplets, have a low precipitation rate, and allow for a longer watering time. Micro sprays or sprinklers are typically used on tree crops to spread the water droplets out over a larger surface. Micro sprays and sprinklers may provide some frost protection if sufficient water amounts are designed for that application. Furthermore, they can be used for agriculture practices such as nurseries, greenhouses, landscapes, and home gardens. The major difference between the two is that micro sprinklers have moving parts, while micro sprayers do not.

All drip/micro irrigations, micro sprays or sprinklers require some degree of filtration to prevent clogging.



Types of preinstalled emitters

DRIPLINE (DRIPPERLINE) is a polyethylene (PE) hose with a wall thickness of about 1.27 mm and a diameter of 1.9 cm or smaller, with the emitters molded and inserted inside the tubing. The only visible part is the hole or holes in the tubing where water is emitted (in-line emitters). If the emitters are installed on the hose in the field it is called on-line. The type of emitter used is usually a pressure compensating diaphragm emitter. Dripline is usually used in agriculture, vegetable gardens, and can be installed below ground for some agricultural crops and for lawns.



DRIP TAPE is relatively inexpensive and is manufactured as a thin flat plastic tube with closely spaced built-in water outlets. Common diameters are 16 mm, 22 mm and 35 mm. The inlet pressures to a drip tape are usually less than 1 bar. The wall thickness can range from 4 to 25 mil. Outlet spacing can vary from 10 to 61 cm, and 30,5 cm is common. This type of product is ideal for row crops. A low cost drip system, water uniformity is usually very good when designed properly. Since the emission holes are so small, they can clog extremely easily and proper filtration is required. Drip tape can in some cases be used for more than one year in agriculture but is typically removed and discarded at the end of each growing season in high cash crops such as strawberries.



COMPONENTS FOR PRESSURISED IRRIGATION

Pressurised irrigation is more efficient than flood irrigation, because all open channels are removed and closed pipes are used. Adding pressure boosting means that the right amount of pressure can be applied to get the water to where it needs to be. The farmer should try to achieve the highest possible efficiency; because once the equipment is paid for, total cost of ownership can be kept down. The best example is the cost of energy, which is the biggest single cost item for the farmer.

To get the best out of a pressurised system, a full irrigation design and analysis of flow and pressure requirements is needed, followed by water source pumping needs and efficiency analysis of the pumps, to get the real and substantial benefits that are possible in the system – this is much more than looking at the pump.

Pressurised irrigation systems can be designed so that the entire block or field is irrigated, without any need for zone valves, if the quantity of water is sufficient and the entire crop in the field requires the same application and water quantity. If the irrigation blocks are broken into smaller blocks and one or more is irrigated at a time due to different application rates and crop requirements, a pump with a variable frequency drive (VFD) may make sense, to achieve the highest efficiency while irrigating all of the blocks. Flow requirements in each block may vary with the same operating pressure, so regulating the pressure with a variable frequency drive (VFD) is important. If the entire field is irrigated, a VFD pump also makes sense if the water source fluctuates, for example with seasonal fluctuations in groundwater level.

A pressurised irrigation system is about much more than just the pump. The benefits of a fully designed system can be substantial – especially savings on energy.

Control, monitoring and data management equipment is increasingly important in simple to complex irrigation systems. Pump control and monitoring can be accomplished remotely so the farmer may not need to drive out to a field to turn on

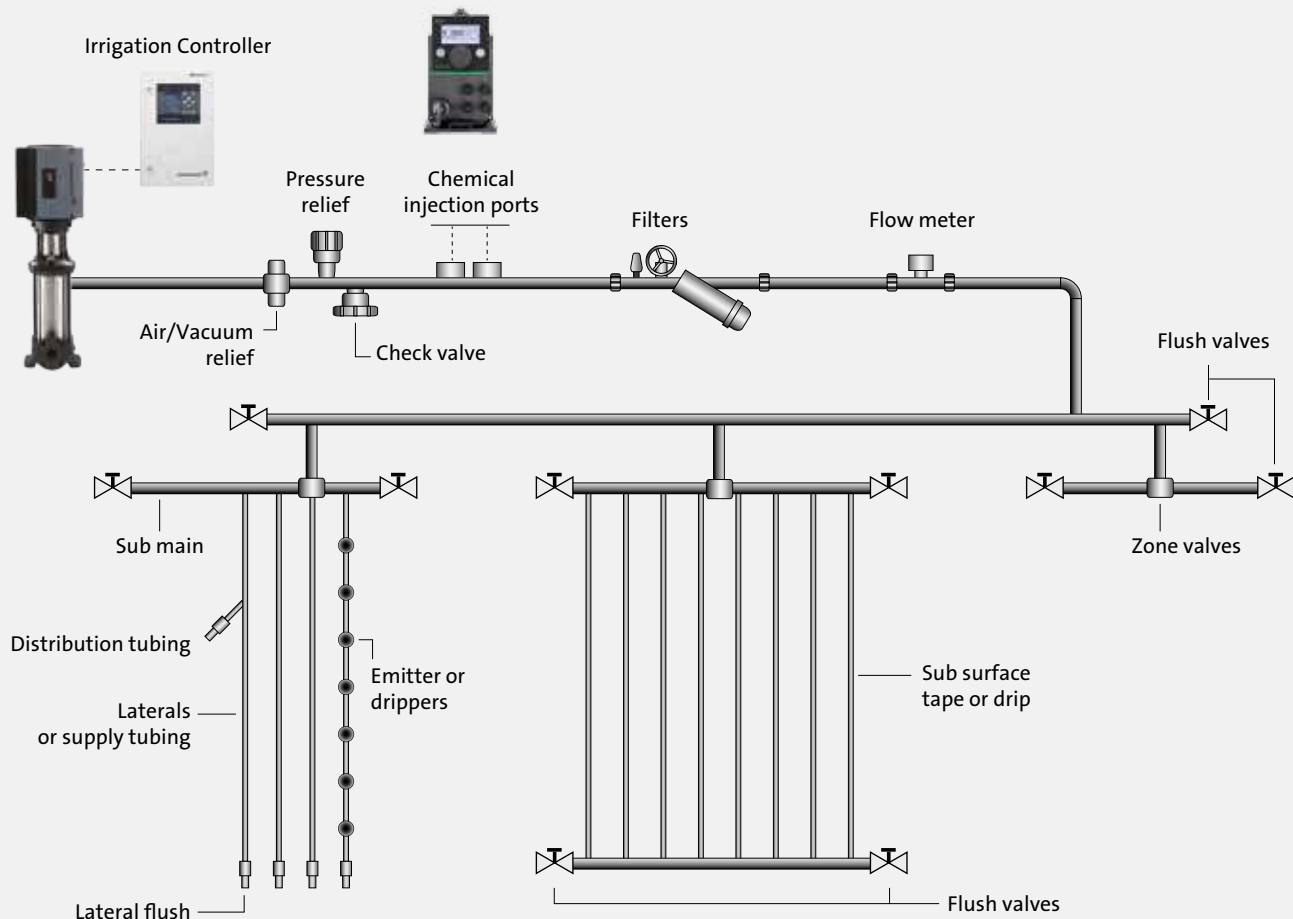



or off the irrigation system. The system can also be monitored for operating pressure, flow and chemical dosing. If an issue occurs an alarm will notify the grower of the issue so it can be corrected. Remote monitoring and controls as well as data collection is becoming more commonplace, saving time, money and resources that make the overall irrigation and pumping system more efficient.

Dosing and disinfection

Many types of chemical injection products are available, from dosing and disinfection pumps, all with their particular advantages and disadvantages. The initial high cost of smart digital dosing pumps is quickly countered by their extremely high precision and uniformity. Some pumps have two way communications and can be remotely monitored. The dose and injection rate can also be changed remotely.

When installing dosing equipment, it is important to ensure compatibility with any additives, such as chemicals that can react with the current water conditions, potentially damaging the pump or components of the irrigation system. For example, iron oxide precipitate in the water can cause clogging, so care must be taken if chlorine is used to treat the water as it can cause iron to percolate out. Test your water and know what issues may occur with the chemicals you plan to apply in any irrigation system.

When the irrigation system works correctly and the water application is uniform, then the application of any fertiliser or chemical will also be uniform.

Filtration

Filtration equipment ensures that organic and inorganic particles such as sand, algae, or silt bigger than the smallest inlet or outlet hole in the system are removed, protecting the irrigation system from clogging. If chemicals or acids must be added for water treatment, be sure to determine if the materials should be injected before or after any filtration equipment. Some chemicals will react with the materials from which the filters are manufactured. Water soluble fertilisers are typically injected after the filters and must be in solution, and chemicals must be tested prior to injection into the irrigation system.

A filtering system should be chosen based on budget, the irrigation system used and water quality. Sometimes a combination of more than one type of filter will need to be used. The degree of filtration is noted by microns or mesh. Filters are solely used to remove particles from water; they cannot take out dissolved solids, salts, and other toxic elements. To change the chemistry of the water, other types of treatment are needed.

Four main methods are used to filter water for irrigation systems: screen filters, media filters, disk filters and centrifugal filters. Media filters backed up with a screen filter may work

best for water with organic and inorganic particles. Check with the manufacture of the emission device for their recommendations on the mesh or micron size of filtration.

Filtration systems require routine maintenance, because they constantly need to be inspected for wear, clogging, tears, and corrosion. They also need to be flushed periodically to remove debris and prevent the growth of microorganisms in the system by injecting algaecides or other chemicals to be preventative.

Filtration systems for microirrigation have to be monitored closely. Even the smallest sand particle can cause damage to the system and a strict flushing routine needs to be followed. A sight glass needs to be installed on the back flush outlet pipe, allowing visible control that the filter is being flushed correctly. Pressure gauges after the pump, before the filters and before the water enters the field also help ensure the system is working properly. Other components of any filter system must include air vents and a pressure relief valve. Check local regulations on the proper use and installation of backflow prevention devices to ensure chemicals and water do not flow back into your well or water source.

Four main methods are used to filter water for irrigation systems: screen filters, media filters, disk filters and centrifugal filters

TYPES OF FILTRATION EQUIPMENT



SCREEN FILTERS are very common and usually the least expensive type of filter. Great for removing hard particles such as sand from water, they do not remove organic matter very well because non-solid materials tend to either slip through the screen or insert themselves in the screen material, where they can be difficult to remove. Screen filters can be washed by hand or flushed with water. Cartridge filters are a variation of screen filters that are able to remove organic matter more effectively.



MEDIA FILTERS force water through a tank that is full of small, sharp-edged objects. These objects are uniform in size, and sharp crushed silica sand is typically used. The sharp edges on these particles will snag organic material, making media filters excellent for removing non-solid matter. However, they are not able to remove hard matter such as sand particles that get mixed in with the media particles. Media filters are cleaned, by backflushing clean, filtered water through the tank.



DISK FILTERS are a cross between a screen filter and a media filter, because they can efficiently remove sand and organic matter. Round disks, each with grooves on one side, are stacked on top of each other, creating tiny spaces where water flows through, trapping all matter that does not fit through the gaps. These disks can easily be cleaned by unshackling them and washing by hand.



CENTRIFUGAL FILTERS are also known as sand separators, because their primary function is removing sand from water. Dirty water enters the filter, where centrifugal forces cause the sand to move to the outside edge of the cylinder and then collect at the bottom of the tank. Sand particles can pass through the system if the filter is not sized properly and at the initial startup and shut down of the flow. A sand separator system is not effective in removing organic matter, as it will only remove particles that are heavier than water.

ACCURACY AND UNIFORMITY	45
LET THE IRRIGATION SYSTEM DO THE WORK	46
PRECISION APPLICATION OF LIQUID FERTILISER	47
DIGITAL DOSING PUMPS	48



077

FERTIGATION & CHEMIGATION

FARMERS ARE INCREASINGLY UNDER PRESSURE TO SAVE COSTS AND AVOID EXCESSIVE FERTILISER AND CHEMICAL USE. FERTIGATION AND CHEMIGATION APPLICATIONS DELIVER THE ACCURACY AND UNIFORMITY REQUIRED.

FERTIGATION & CHEMIGATION



For agricultural food production and plant production, the demand for more accurately measured inputs for both fertilisers and chemicals along with water usage has become the norm. The increased cost of all inputs in growing food will only continue to increase as the world's existing water and farmland resources will need to produce more with less.

The demand for safe food supply places increased demands on the growing and harvesting of food. The use of proper amounts of fertilisers in the growing of those crops and the handling of the harvest as well requires accurate applications of chemicals to ensure that food is not contaminated with any harmful substances.

This is also true for greenhouse and hydroponic farming systems. Something that we all now expect to find on our grocery shelves is fresh fruits and vegetables. The application of the fertilisers and chemicals to keep these growing systems free of any pests or harmful agents is even more critical than with outdoor field crops. Chemical and fertiliser dosing systems are commonplace for both growing and disinfection systems.

What is Fertigation/Chemigation?

FERTIGATION is the application of fertiliser and or soil amendments with your irrigation system water. A fertiliser is a substance that contains one or more plant nutrients to promote plant growth. This can also include gypsum and lime

CHEMIGATION is the application of pesticides or system maintenance products through an irrigation system. These can include-herbicides, insecticides, fungicides, fumigants, plant growth regulators, rodenticides, disinfectants, sanitisers, buffering agents, desiccants, defoliants, sprout inhibitors and spray adjuvant.

Advantages of Fertigation/Chemigation:

- Uniform application – delivered with irrigation
- The right amount applied to the crop
- Additional field equipment not necessary, reducing costs and maintenance
- Reduced timelines through applying fertiliser with irrigation
- Reduced compaction
- Reduced risk, as the operator has little or no contact with chemicals or fertilisers
- Reduced overfeeding and underfeeding of the crop
- Avoid the extra equipment and resources for dry applications

Plant production or container nurseries for crops that are transplanted into our fields or gardens need to be clean of any plant or soil-borne pests that may spread and harm existing farmlands or gardens. The use of chemicals and fertilisers ensure growth and that pests are not spread, as well as protecting the environment. Again, the accuracy of fertiliser application into the irrigation system in addition to chemicals to keep the plants free of pests is critical.

The trends today are for increasing environmental regulation and legislation. The monitoring of our groundwater and surface water will see additional regulations due to the risks of the leaching of chemicals and nitrates into our existing water sources. We will need to apply only those fertilisers and chemicals that the plant requires with as little waste as possible. Water runoff from irrigated farmlands will be monitored to a greater extent than today, with increasing local, state and federal regulations.

In future, demands will increase for application accuracy, for tracking of where food comes from and what was applied to it before it ended on the grocery shelf. The application of fertilisers and chemicals will need to be measured and tracked. The tracking of the data for what was applied to the crop will be collected and monitored and shared with consumers, and with local, state and federal agencies. You can't manage what you can't measure and to measure accurately you require state of the art dosing equipment.

With more mechanised irrigation and the ability to apply fertilisers and chemicals through those systems, we will see increased yields. Growers need to stay competitive, have new systems in place, and reduce labor costs. This means applying only those fertilisers and chemicals necessary for maximum crop production, and for keeping our environment safe. This can only be done with precision application equipment.

ACCURACY AND UNIFORMITY OFFER MANY ADVANTAGES

As commercial liquid fertilisers are concentrated and expensive, it is vitally important that the fertigation method used is uniform and precise. If this is not achieved, then the crops can be damaged, or growth across the field becomes irregular.

The increase in the use of pressurised irrigation systems such as drip and sprinklers, mechanised irrigation systems such as center pivots, and other irrigation systems has also seen the growth of fertigation and chemigation. The irrigation systems reduce the time and labor that it once took for the application of fertilisers and chemicals.

The fertigation and chemigation system should also reduce water runoff and reduce environmental issues. As irrigation systems and components have become more efficient and the uniformity of these systems has been improved, so has the efficiency and uniformity of the application of the fertilisers and chemicals.



There are many advantages with fertigation or chemigation applications. If the uniformity of the irrigation system is high, the uniformity of the chemical application will also be high. Uniformity may change due to nozzle wear, operating pressures, valves or other irrigation system components; however it is a straightforward matter to check up on the uniformity of the irrigation system and tune up the system prior to any nutrient or chemical addition.

The economic advantages are many. Only the required amount of nutrients and chemicals is applied to the field being irrigated, saving costs and reducing waste. Costs can be lowered further by using concentrated solutions. Furthermore, the expense of additional field application equipment is not necessary, and the additional cost of upkeep and maintenance of that equipment is reduced. In all, the application is less labor intensive, and this also makes it easier to meet safety requirements. Application can be automated through the use of integrated dosing systems.

As fertilisers can be applied through an irrigation system, the need to wait for a field to dry after irrigating to allow driven equipment to enter the field is eliminated. Nutrients and chemicals can be applied during the irrigation. Scheduling is much more exact, simplifying timelines.

With the irrigation system applying the nutrients or chemicals, additional tractors or spray equipment are not driving through the field, reducing compaction. Hazards to the operator are also reduced, because chemicals and fertilisers are injected into the water stream with little or no contact with operator. Operators are not in the middle of the irrigated area with chemical or fertiliser application equipment. Solutions can be dosed directly

from bulk storage containers without the need for mixing or other handling.

LET THE IRRIGATION SYSTEM DO THE WORK

Choosing a fertigation system means letting the irrigation do the work, and there is no need for costly chemical application equipment that also requires maintenance. Overfeeding and underfeeding of the crop is also reduced, because the uniform application of chemicals and fertilisers is easily controlled for the prescribed quantity over the given area.

Furthermore, dry fertilisers applied by mechanical means require additional equipment such as tractors and fertiliser drills or spreaders. Once applied, they must be irrigated uniformly so that they dissolve at a uniform rate. To achieve a uniform application or reasonably uniform application means either waiting for rain or using a pressurised irrigation system. If a pressurised irrigation system is used, why not just apply the material through that equipment? The farmer then knows that the correct quantity of material was applied while also irrigating the crop. The overall amount of chemicals applied can be reduced when compared to the dry application. Fertilisers can also be applied several times during the growing season, when required by the plants during the irrigation process.

With the installation of more and more pressurised irrigation systems such as center pivots, drip irrigation systems in permanent crops and tape irrigation systems in row crops, there is an ever increasing ability for applying fertilisers and other chemicals through the irrigation systems. Also, as fertilisers have become more expensive, the requirement is to apply only



Dosing into a center pivot is one example of types of a high-flow fertigation application requiring precision and uniformity.



Drip/micro spray fertigation applications use smaller pumps with low flow with the same requirements for precision and uniformity



what is required with accurate timing and in precise quantities, so that fertilisers remain within the root zone of the crop being fertilised. This reduces the quantity of material and the possibility of leaching of the chemicals past the root zone and being lost. This practice will and has reduced nitrates from entering our water sources.

PRECISION APPLICATION OF LIQUID FERTILISER

Fertilisers come in many forms and farmers who have been mixing granular fertilisers into water are now beginning to realise that this may not be the most economical and often can be inaccurate. Pressurised irrigation systems require water soluble fertilisers and many of the dry formulations may contain ingredients that are not totally soluble.

Commercially available liquid fertilisers and effective, accurate dosing devices are becoming the norm. The results are

improved crop yields and the use of fewer inputs that also generate greater profits.

Liquid fertilisers have a consistent concentration in content and provide a greater flexibility for fertigation methods, such as foliar spray, soil injection, drip or micro spray. They also reduce the need to handle heavy bags and dust exposure when applying dry materials. Liquid fertilisers eliminate blockages of hoses and tubes and allow rapid uptake.

Precision application is more important now and will continue to be refined. The cost of fertilisers and chemicals will only increase and the precision of application will only need to be improved. The goal must be to apply only what the plants can utilise without any leaching or run off. Chemigation practices must be such that those chemicals applied are only applied to the plant or soil surfaces to which they are intended. The reduction of overspray and wind drift must be accounted for and eliminated.

DIGITAL DOSING PUMPS BEST FOR UNIFORMITY AND ACCURACY

Of the many pump types that can be used for fertigation applications, motor driven dosing pumps – and even better yet digital dosing pumps – provide extremely high precision. Digital dosing pumps allow fertilisers to enter the irrigation water pipe line uniformly and well mixed. These pumps also provide flexibility in control through simple manual start/stop or proportional control from a water flow meter.

Commonly available fertigation pump types

The following table provides a comparison between the advantages and disadvantages of the most commonly available fertigation pump types.

Digital dosing solutions have proven their ability to balance the needs of high yields for the farmer with sustainable farming practices



Type	Advantages	Disadvantages
Electric VFD Motor Crank Driven	<ul style="list-style-type: none"> • Highly accurate • Easy initial setup • Easy to adjust • Very flexible • Low maintenance • Initial high investment 	<ul style="list-style-type: none"> • Initial high investment
Hydraulic Driven	<ul style="list-style-type: none"> • Relatively inexpensive • No electrical power required • Easy to operate • Low maintenance 	<ul style="list-style-type: none"> • Not very accurate • No automation • Very limited operating range • No possibility of remote monitoring and control • Pulsing dosage
Electric Solenoid Driven	<ul style="list-style-type: none"> • Relatively inexpensive • Low maintenance • Many options for dosing monitoring and control 	<ul style="list-style-type: none"> • Marginal accuracy • Complicated initial setup • Difficult adjustment • Limited operating range per unit • Pressure spikes
Electric Motor Cam Driven	<ul style="list-style-type: none"> • Relatively inexpensive • Low maintenance • Many options for dosing monitoring and control 	<ul style="list-style-type: none"> • Marginal accuracy • Complicated initial setup • Low flexibility • Limited operating range per unit • Difficult to use • Pressure spikes
Pressure Differential Venturi Driven	<ul style="list-style-type: none"> • Inexpensive • Low maintenance 	<ul style="list-style-type: none"> • Highly inaccurate • Low flexibility • Difficult adjustment • Additional pump required in some installations
Electric Motor/Engine and gear box Piston Driven	<ul style="list-style-type: none"> • Moderate expense • Easy setup • Easy adjustment 	<ul style="list-style-type: none"> • Moderate accuracy • High maintenance
Electric Motor Peristaltic Pump Driven	<ul style="list-style-type: none"> • Inexpensive • Easy setup • Easy adjustment 	<ul style="list-style-type: none"> • Moderate maintenance • Moderate accuracy
Engine Driven Roller Pump	<ul style="list-style-type: none"> • Inexpensive 	<ul style="list-style-type: none"> • High maintenance • Low accuracy • Low flexibility • No automation

HOW TO SIZE A FERTIGATION PUMP

STRAWBERRY FIELDS

The following fertigation sizing example is for a 4 hectares field of strawberries, where the irrigation system irrigates all 4 hectares in one set. The water source is from a well, pumping the required 113.6 m³/h.

The irrigation system operating pressure at well discharge is 2.8 bars. Some additional information about the field and irrigation system:

Crop:	Strawberries
Crop Spacing:	1.32 meter beds (Double row with single subsurface drip tape)
Field Size:	4 hectares (303 beds at 100 meter row lengths)
Irrigation type:	Drip tape 1.89 litres per minute/30.48 meters
Soil type:	Sandy loam

100 meter row ÷ 30.48 = 3.3 x 1.89 litres/minute = 6.26 litres/minute per row
330 rows x 6.26 litres/minute = 1896.8 litres/minute or 113.8 m³/hour

Adding fertigation to the irrigation system requires a number of considerations and calculations.

Determine the following:

- A.** Determine the material(s) to be injected
- B.** Determine amount of material to be applied/hectares
- C.** Determine the field size
- D.** Determine the required total quantity of material to be applied
- E.** Determine the total kg of material to be injected
- F.** Determine the gallons of material to be injected
- G.a** Determine the length of time allowed to inject the required amount of material. For this example: Irrigation system operates for 8 hours, required amount of material is 108 litres
- G.b** Determine the length of time and injection rate required if a required dilution is required:
 - System flow rate:
 - Dilution required example 100ppm
 - Determine dilution factor
 - Calculate injection rate
 - Injection time based on 100 ppm dilution at the 35.5 litres/hour rate to apply 108 litres of nitrogen

For our strawberry field example:

- A.** **UAN-32 (32% Nitrogen, 1.3 kg/litre).**
- B.** **11.2 kg of nitrogen per hectare**
- C.** **4 hectares**
- D.** Total nitrogen 11.20 kg/ha x 4 hectare = **44.8 kg nitrogen**
- E.** UAN-32: 44.8 kg ÷ 0.32 = **140 kg**
- F.** UAN-32: 140 kg ÷ 1.3 kg/litre = **108 litres to be injected**
- G.a** 108 litres ÷ 8 hours = 13.5 litres/hour ÷ 60 = **0.225 litres/minute injection rate.**
Dosing pump requires to pump 0.225 litres/minute against a 2.8 bar system operating pressure.
- G.b.** **113.8 m³/hour** flow rate in irrigation system
100ppm nitrogen (UAN-32)
0.32 x 1,000,000 ÷ 100 ppm = **3,200 dilution factor**
Injection rate: 113.8 m³/h ÷ 3,200 = **0.0355 m³/hour** or **35.5 litres/hour** again against a 2.8 bars system operating pressure
108 litres ÷ 35.5 litres/hour = 3 hours

- H.** Determine the pressure of the system that the dosing pump will be pumping against
- I.** Determine the location of the dosing pump and location of the injection site into the system
- J.** Determine if a tank to store materials will be required
- K.** Determine if a tank mixer will be required
- L.** Determine what is available for power and location

Note:

The injection rate and injection time for the application must be determined so that leaching of any nutrients or chemicals are prevented. This may require that the nutrients are injected in very short intervals and not allow leaching. Another method would be to inject at the end of an irrigation cycle to prevent leaching. Determine which method may be used so that the nutrients or chemicals injected remain in the root zone of the plant being irrigated.

Selecting the pump

The dosing pumps that can be used in example **G.a** to deliver 13.5 litres/hour are the Grundfos DDA 30-4, DMX25-3, or DMH 36-16. The least costly will be the DDA 30-4.

The dosing pumps that can be used in example **G.b** to deliver 35.5 litres/hour are the Grundfos DME 60-10, DMX 35-10, or DMH 31-200.

CONTROLS AND MONITORING	52
REMOTE MANAGEMENT AND DATA COMMUNICATION	52
HOW COSTS ARE SAVED	53



088



CONTROLS, INFORMATION AND AUTOMATION

DATA MANAGEMENT IS INCREASINGLY THE MEANS TO MAKE COMPLEX IRRIGATION SYSTEMS SIMPLE TO OPERATE. THIS IS DONE IN MANY WAYS; THE SIMPLE MONITORING OF PUMP DATA FOR MAINTAINING THE HIGHEST EFFICIENCY, REMOTE SURVEILLANCE AND AUTOMATED CONTROL FOR IRRIGATION SCHEDULING, AND ALSO BY TAKING ADVANTAGE OF THE EFFICIENCY BENEFITS OF VARIABLE SPEED USING VFDS.

CONTROLS, INFORMATION AND AUTOMATION

Increasingly, farmers are discovering the benefits of remote monitoring, controls and variable speed using Variable Frequency Drives (VFDs) but few take advantage of the possibilities of what can appear to be an overly complex solution. A range of components and total solutions are available today that enable irrigation equipment installers to take over the monitoring of farmers' pumps as part of a service package. This lets farmers focus on what they do best: optimising crop yields.

An irrigation system is more than pumps and often involves a range of equipment from many different suppliers, for example the irrigation unit, weather data system, soil moisture monitoring, and so on. Farmers are understandably reluctant to bring together equipment from different suppliers in a single, unified surveillance system, and even more so to place management of the irrigation system at a computer.

Farmers generally want to decide for themselves what should happen; the economic consequences are simply too great if something should go wrong. These concerns, however, can be overcome. With many players on the market aware of the issues, integration of equipment is getting easier.

Components and solutions are available today that enable irrigation equipment installers to take over the monitoring of farmers' pumps as part of a service package.

This lets farmers focus on what they do best: optimising crop yields.

CONTROLS AND MONITORING

Controls and monitoring are becoming more important for agricultural applications. Turf applications and golf courses are already using smart controls that capture soil moisture, climate data, and the amount of irrigation that is required.

Irrigation can then be scaled up and down and scheduled according to this. However, the economic consequences for agriculture are substantially higher than for turf or landscaping applications where under-irrigated grass will quickly recover. Under-irrigated crops do not necessarily recover, at huge cost for the farmer.

However, crop factors change more during a year and with many more variables compared to turf and landscaping. At the water source, a controller is needed that knows what to pump and when to pump from where; for example, from many different groundwater wells of different depths, where water levels can vary.

Filter stations also have controllers. With this information available online, remote monitoring is possible with alarms. For example, mixing different water sources from deep wells and canals is something that is happening more regularly to ensure sufficient water. With different characteristics and levels of contaminants, these different water sources need to be blended and treated accordingly.

Disinfection of the irrigation system – using chlorination, for example – to remove algae is necessary to avoid clogging. In greenhouses, small problems such as fungal growth in hydroponics can quickly get out of hand. These need very precise dosing, and controls for critical functions have to be extremely precise, as should the automated dosing program.

REMOTE MANAGEMENT AND DATA COMMUNICATION

A remote management solution with communication interfaces using open standards that easily integrate the pumps and pump systems into SCA DA (supervisory control and data acquisition) systems, PLCs (programmable logic controllers) and other controller or monitoring systems offers the farmer a range of options including stand-alone pump surveillance, components that can be integrated with other equipment, and complete system monitoring with remote management.

Ensuring quick and easy communication with pumps and pumping systems enables the installer to give a much better service to the farmer. Transparency of data means that planning and monitoring status data become much easier and result in improved reporting, increased understanding of the overall pump and irrigation system, possible improved water pumping availability, and improved irrigation scheduling. Easy and rapid analysis and optimisation of the system's engineering is also made possible.

Open and interoperable data bus networks are becoming increasingly important for supervisory systems monitoring pumps systems. Grundfos communication and control solu-

tions use a new fieldbus concept that creates an optimal, flexible and therefore cost-effective integration of field devices such as pumps or pumps systems into management systems.

The Grundfos CIM/CIU communication interfaces using open standards offer many advantages for the installer. The use of a serial data bus connection can reduce the installation cost of wiring field devices by up to 40%. Having the data available on a supervisory system increases accessibility of the system for control and management, and by optimising the system, the operating costs can be significantly reduced.

These open communication standards offer vendor neutral, flexible and secure communication solutions that optimise and protect investments. Once collected, data transmitted from technical systems using these interfaces can be transferred to related units. This means that the data is available for other purposes, for example calculating operating costs for accounting purposes.

These interfaces enable fieldbus communication on your pump and offer one communication solution for all products for central data monitoring, optimised remote set point control and preventative maintenance. The wall-mounted CIU unit is equipped with a 24 to 240 VAC/VDC power supply.

The modular design is prepared for future needs and is based on standard functional profiles. Grundfos CIM/CIU standard communication interfaces are easy to install and commission for complete process control with Grundfos pump systems.

ADD A VFD FOR OPTIMAL EFFICIENCY

For all types of irrigation and not only for sprinkler irrigation, it is important to be able to control the flow and pressure if you are to achieve high irrigation efficiency. It is not only the pump that is important in irrigation, but even more so the regulation of the pumps.

If the irrigation set-up requires unchanged flow and pressure, the most efficient pump to use is a single-speed pump operating at its best efficiency point. But if either the flow or pressure requirements are variable, or if irrigation zones are opened or closed, the most efficient way to regulate flow and pressure is to use a VFD. Not only will the uniformity be maintained at an optimal level, there will also be a great power saving for the pump, and that is probably the biggest advantage.

Of course, flow and pressure can easily be regulated by means of a valve, and this is actually still the most common way to adjust pump performance. But the approach is similar to driving a car with full throttle, and then using the brakes to adjust the speed.



A VFD converts the 50 or 60 Hz input frequency to an output frequency that can vary from 0 to its maximum frequency. The default setting of maximum frequency is typically either 50 or 60 Hz, depending on location. When the frequency is changed, the speed of the motor, and thereby the pump speed, is changed. This is what is meant by performance regulation. See the table on page 71, chapter 11 for a performance comparison.

In almost all cases where irrigation conditions change from one year to another through the course of the season – or even from one day to another – regulating pump speed offers advantages. Examples of applications where adjusting the speed of the pump to the actual performance requirements provide potentially large benefits are the opening and closing of irrigation zones, pivots equipped with a corner section or an end gun, and situations with varying inlet pressure.

VFDs can also be used as an over-frequency drive, if pump performance needs to be increased even further. However, this may require a larger motor for the pump and should only be done following consultation with the pump supplier. VFDs can also provide soft start and soft stop, minimising the risk of water hammer in the system. In addition, the need for motor overload protection is eliminated, as this functionality is built into the VFD.

Not every application benefits from the addition of a VFD; for example, filling an open reservoir or pond from a groundwater source simply requires running the pump at full speed until the reservoir or pond is full. However, as we have seen, there are many applications where adding variable speed to the pump using a VFD makes good sense.

SEE WHERE A VFD CAN SAVE ON ENERGY, WATER, AND COSTS

Opening and closing irrigation zones

Typically used where different crops need different amounts of water, or when the same crop is planted and harvested at different times in order to extend the season. With a VFD installed with the pump, a pressure sensor will tell the VFD to reduce the speed of the pump when a zone is shut off, ensuring the exact same pressure is maintained in the zone that remains open. In addition, the power consumption of the pump will be reduced to almost half that when both zones are open.

Pivots with corner section and end gun

When a pivot is equipped with a corner section or an end gun, it requires more pressure and flow when on than when

off. Tests have shown that energy savings of at least 20% can be achieved if a VFD is installed with the main pivot pump. The pressure at the sprinklers remains constant, and water savings can also be expected.

Varying pump inlet pressure

Pump inlet pressure can vary significantly, especially for deep-well submersible pumps. The water table typically varies over a season or from one year to another. In both cases, if a VFD has been installed with the pump, the VFD will regulate the performance of the pump so the outlet pressure remains constant and therefore maintains an optimal irrigation process.

HOW COSTS ARE SAVED

Integration of monitoring, controls and variable speed using VFDs means that the remote management of irrigation is something we will see much more of in the very near future. Alerts, reporting and diagnostics for the pump, variable frequency drive, tank, well or other water source levels and motor protection device can be seen on the same screen, leaving the irrigator with the option of full automation of the irrigation, or to maintain control, using the information made available.

Many solutions today offer the farmer remote programming, management, diagnostics and reporting via any web-enabled device such as a desktop computer, laptop, iPad or tablet or smart phone. In recent years new technology has made it possible to expand the number of parameters that are monitored.

More detailed information about the pump and the pump operation makes it easier to take corrective action; extending the pump life and reducing energy consumption.



RENEWABLES
A SOLID INVESTMENT

59



09



RENEWABLE ENERGY SOURCES

THE COST OF GENERATING CLEAN ENERGY FROM RENEWABLE SOURCES HAS DECREASED SHARPLY. PUMPS FITTED WITH PERMANENT MAGNET MOTORS ENABLE THE EFFICIENT USE OF ENERGY FROM WIND OR SOLAR SOURCES. THIS KIND OF PUMP SYSTEM OFFERS THE PERFECT WATER SUPPLY SOLUTION IN AREAS WHERE THE POWER SUPPLY IS NON-EXISTENT OR UNRELIABLE, OR FOR DRIP IRRIGATION OR LANDSCAPE IRRIGATION ANYWHERE.



RENEWABLE ENERGY SOURCES

In recent years, the cost of generating clean energy from renewable sources has decreased sharply. At the same time, governments around the world are insisting that a greater proportion of energy is generated from renewable sources. The drive to increase motor efficiency and reduce CO₂ emissions has led to increasing regulation as to how energy is generated. This is a trend that is set to continue.

Renewable energy systems are increasingly common in irrigation systems in, for example, the olive orchards and vineyards of southern Europe. In particular, renewable energy systems have proved ideal for drip irrigation systems, supplying a steady supply of water through an extensive network of hosing delivered directly to the roots. This minimises evaporation and reduces water consumption.

Solar and wind powered pumping systems present a cost effective, flexible and secure water supply solution using clean energy. Utilising solar and wind power reduces energy costs to zero and saves on the costs of energy infrastructure, wherever

the application is installed. Solar and wind powered pumping systems offer tangible benefits, for example from easy installation, as they are typically supplied as a plug-and-go solution. It is a relatively simple matter to tailor the pumping solution to the specific application and local conditions. Built-in protection features for the pump motor ensure a low maintenance pumping solution.

Designed for continuous as well as intermittent operation, solar and wind powered pumping systems are especially suitable where cost is all-important. Once the initial investment in the system is made, operating costs are reduced to simple maintenance, for example the cleaning of the solar panels.

RENEWABLES A SOLID INVESTMENT

Pumping systems using renewable energy sources provide a sustainable, reliable and cost-efficient alternative to grid-based systems, with substantial benefits for the irrigator's investment. The lifecycle costs will be considerably lower than with other



water supply systems, because substantial sums are saved on reduced maintenance costs and no energy costs.

For a renewable energy-based system, the initial purchase price is the greatest investment. Once the pump system is installed, the irrigator no longer gets energy bills, meaning a rapid pay-back time on the initial investment. If the pump system is sized, configured or packaged to fit the application right from the start, costs for installation, commissioning and service are also reduced.

Renewable energy-based pump systems are a good investment. Governments increasingly encourage investors to choose renewable energy in irrigation, and there is a growing awareness of the low risk of such investments. This is because the installation is not dependent on energy prices staying low to ensure a payback on the investment.

The efficiency of solar and wind energy generation has been increasing over many years, and as global manufacturing capacity increases, costs are also falling for building solar panels and windmills. This has opened up the market for a larger power size off-grid system, as the initial investment for a large system has become more acceptable, and the return-on-investment is increasing.

HOW DOES A RENEWABLE ENERGY SOURCE PUMP WORK?

A renewable pump is like a standard pump. However, the motor on a renewable pump must be able to handle the power from solar panels or a windmill rather than from the usual power grid.

A solar panel produces DC power. The more radiation from the sun, the more power the panels will produce.

An inverter, or converter, converts DC to AC. This power is also dependent on sunlight radiation: the more radiation, the higher the voltage. The converter also links a frequency to the AC voltage, ensuring that the proportion of voltage and frequency remains constant. The output is identical to the output from a standard VFD, except for the lower voltage.

A special function of the inverter is to monitor its own power generation and make sure it runs at maximum at all times. This is called 'maximum power point tracking', and is done several times per second.

THE FUNDAMENTALS	62
FRICITION LOSS	63
VAPOR PRESSURE	63



10



BASIC HYDRAULICS

THIS CHAPTER PRESENTS A BASIC INTRODUCTION TO HYDRAULICS, TO AID UNDERSTANDING OF HOW A PUMP WORKS AND HOW WATER BEHAVES WHEN PART OF AN IRRIGATION SYSTEM.

ALL DESCRIPTIONS AND DATA THAT FOLLOW ARE APPLICABLE TO WATER ONLY.

BASIC HYDRAULICS



THE FUNDAMENTALS

When we discuss pumps, only three major parameters are of interest to us:

Flow	Designation	Q	Unit	m ³ /h	Cubic meter per hour
Head (pressure)	Designation	H	Unit	m	meters
Energy	Designation	P	Unit	kW	Kilowatt

However, when dealing with the installation and operation of pumps, there are a further two parameters that are important:

1. friction loss in the piping system
2. elevation lift of the fluid.

The interaction between Q, H and P is: $P = Q \times H \times c$, where c is a constant depending on the pump efficiency, gravity and the fluid type.

- With double flow, the power will also double
- With double head, the power will also double
- If both flow and head doubles, then the power will be four times higher

Transportation of any kind of fluid in a piping system creates friction, and thereby losses. That means loss of energy and loss of pressure. It is the velocity of the fluid that creates the pressure loss. The higher the velocity, the higher the loss.

The fluid velocity (v) in a given pipe can be calculated from the flow.

$$v = \frac{Q}{A} \times c$$

where c is a constant to convert the velocity to meters per second.

In order to minimize the pressure loss it is usually recommended to keep the velocity in a pipe below 2-4 m/s, depending on the situation.

Head losses in ordinary water pipes

Upper figures indicate the velocity of water in m/sec.

Lower figures indicate head loss in metres per 100 metres of straight pipes.

Quantity of water			Head losses in ordinary water pipes														
m ³ /h	Litres/min.	Litres/sec.	Nominal pipe diameter in inches and internal diameter in [mm]														
			1/2"	3/4"	1"	1 1/4"	1 1/2"	2"	2 1/2"	3"	3 1/2"	4"	5"	6"			
0.6	10	0.16	0.855 9.910	0.470 2.407	0.292 0.784												
0.9	15	0.25	1.282 20.11	0.705 4.862	0.438 1.570	0.249 0.416											
1.2	20	0.33	1.710 33.53	0.940 8.035	0.584 2.588	0.331 0.677	0.249 0.346										
1.5	25	0.42	2.138 49.93	1.174 11.91	0.730 3.834	0.415 1.004	0.312 0.510										
1.8	30	0.50	2.565 69.34	1.409 16.50	0.876 5.277	0.498 1.379	0.374 0.700	0.231 0.223									
2.1	35	0.58	2.993 91.54	1.644 21.75	1.022 6.949	0.581 1.811	0.436 0.914	0.269 0.291									
2.4	40	0.67	1.879 27.66	1.168 8.820	0.664 2.290	0.499 1.160	0.308 0.368										
3.0	50	0.83	2.349 41.40	1.460 13.14	0.830 3.403	0.623 1.719	0.385 0.544	0.229 0.159									
3.6	60	1.00	2.819 57.74	1.751 18.28	0.996 4.718	0.748 2.375	0.462 0.751	0.275 0.218									
4.2	70	1.12	3.288 76.49	2.043 24.18	1.162 6.231	0.873 3.132	0.539 0.988	0.321 0.287	0.231 0.131								
4.8	80	1.33		2.335 30.87	1.328 7.940	0.997 3.988	0.616 1.254	0.367 0.363	0.263 0.164								
5.4	90	1.50		2.627 38.30	1.494 9.828	1.122 4.927	0.693 1.551	0.413 0.449	0.269 0.203								
6.0	100	1.67		2.919 46.49	1.660 11.90	1.247 5.972	0.770 1.875	0.459 0.542	0.329 0.124	0.248 0.124							
7.5	125	2.08		3.649 70.41	2.075 17.93	1.558 8.967	0.962 2.802	0.574 0.809	0.412 0.365	0.310 0.185	0.241 0.101						
9.0	150	2.50		2.490 25.11	1.870 12.53	1.154 3.903	0.668 1.124	0.494 0.506	0.372 0.256	0.289 0.140							
10.5	175	2.92		2.904 33.32	2.182 16.66	1.347 5.179	0.803 1.488	0.576 0.670	0.434 0.338	0.337 0.184							
12	200	3.33		3.319 42.75	2.493 21.36	1.539 6.624	0.918 1.901	0.659 0.855	0.496 0.431	0.385 0.234	0.251 0.084						
15	250	4.17		4.149 64.86	3.117 32.32	1.924 10.03	1.147 2.860	0.823 1.282	0.620 0.646	0.481 0.350	0.314 0.126						
18	300	5.00				3.740 45.52	2.309 14.04	1.377 4.009	0.988 1.792	0.744 0.903	0.577 0.488	0.377 0.175	0.263 0.074				
24	400	6.67				4.987 78.17	3.078 24.04	1.836 6.828	1.317 3.053	0.992 1.530	0.770 0.829	0.502 0.294	0.351 0.124				
30	500	8.33					3.848 36.71	2.295 10.40	1.647 4.622	1.240 2.315	0.962 1.254	0.628 0.445	0.439 0.187				
36	600	10.0					4.618 51.84	2.753 14.62	1.976 6.505	1.488 3.261	1.155 1.757	0.753 0.623	0.526 0.260				
42	700	11.7						3.212 19.52	2.306 8.693	1.736 4.356	1.347 2.345	0.879 0.831	0.614 0.347				
48	800	13.3						3.671 25.20	2.635 11.18	1.984 5.582	1.540 3.009	1.005 1.066	0.702 0.445				
54	900	15.0						4.130 31.51	2.964 13.97	2.232 6.983	1.732 3.762	1.130 1.328	0.790 0.555				
60	1000	16.7						4.589 38.43	3.294 17.06	2.480 8.521	1.925 4.595	1.256 1.616	0.877 0.674				
75	1250	20.8							4.117 26.10	3.100 13.00	2.406 7.010	1.570 2.458	1.097 1.027				
90	1500	25.0							4.941 36.97	3.720 18.42	2.887 9.892	1.883 3.468	1.316 1.444				
105	1750	29.2								4.340 24.76	3.368 13.30	2.197 4.665	1.535 1.934				
120	2000	33.3								4.960 31.94	3.850 17.16	2.511 5.995	1.754 2.496				
150	2500	41.7									4.812 26.26	3.139 9.216	2.193 3.807				
180	3000	50.0										3.767 13.05	2.632 5.417				
240	4000	66.7											5.023 22.72	3.509 8.926			
300	5000	83.3												4.386 14.42			
			90° bends, slide valves	1.0	1.0	1.1	1.2	1.3	1.4	1.5	1.6	1.6	1.7	2.0	2.5		
			T-pieces, non-return valves	4.0	4.0	4.0	5.0	5.0	5.0	6.0	6.0	6.0	7.0	8.0	9.0		

FRICITION LOSS

Friction losses occur in the water pipe, in the elbows, in T's, in valves, and so on. The friction loss is dependent on the flow and is a constant for the device.

Pipes are a special situation. Here the friction loss is also dependent on the length and the surface of the pipe. All pipe manufacturers have their own pipe loss tables that they make available and friction loss data can be obtained from the manufacturer of the equipment. An example is shown below for water in plastic pipes. It is the sum of the friction losses from all components in an irrigation system that determines the total friction loss.

Friction loss depends on the viscosity of the fluid. For our purposes, the only friction loss referred to is for water.

VAPOR PRESSURE

Water boils at 100°C, although this is only true as long as the atmospheric pressure is normal. When the pressure drops below the atmospheric pressure, water will boil at much lower temperatures. As an example, if the pressure drops to 0.1 bar, water will start boiling already at 45°C. The atmospheric pressure is also lower at higher elevation. This phenomenon becomes an important issue when working with pumps.

See 'Cavitation' in Chapter 11.

CENTRIFUGAL PUMP TYPES	66
CAVITATION	67
PUMP PERFORMANCE	68
PERFORMANCE REGULATION	69
ELECTRIC MOTORS	71
MOTOR PROTECTION	72



11



PUMPS AND MOTORS

PISTON PUMPS, EJECTOR PUMPS, SCREW PUMPS, PERIPHERAL PUMPS AND PROGRESSIVE CAVITY PUMPS ARE SOME OF THE DIFFERENT TYPES OF PUMPS. HOWEVER, THE ONLY PUMP TYPE WIDELY USED IN IRRIGATION IS THE CENTRIFUGAL PUMP AND IS THE ONLY PUMP TYPE DISCUSSED HERE.

PUMPS AND MOTORS

CENTRIFUGAL PUMP TYPES

The centrifugal pump has a stationary part and a rotating part. The rotating part is called the impeller. The impeller has a number of vanes which force the water to rotate and creates flow.

The stationary part is called the pump housing, or pump bowl. The bowl also has a number of vanes called guide vanes. Their function is to stop the water's rotation and to convert the energy in the rotation to pressure.

- **SINGLE STAGE PUMPS VERSUS MULTISTAGE PUMPS**

Single stage pumps have only one impeller and one pump housing. The pressure is limited to what that specific pump impeller type can produce.

Multistage pumps have several impellers and pump housings or bowls. If a single-stage pump can generate 3 bar, then a two stage pump with the same type of impeller and bowl can generate 6 bar, a three stage pump with the same type of impeller and bowl will generate 9 bar and so on.

Deep-well submersible pumps are most often multi-stage pump types. Besides generating a static pressure for the application, they have to generate an additional pressure in order to lift the water from deep underground. This requires typically a multi-stage pump.

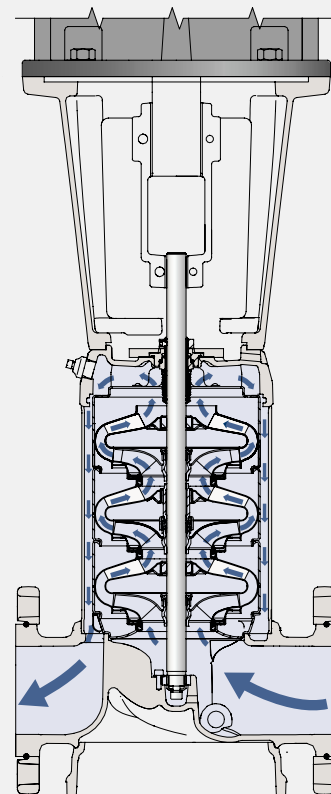
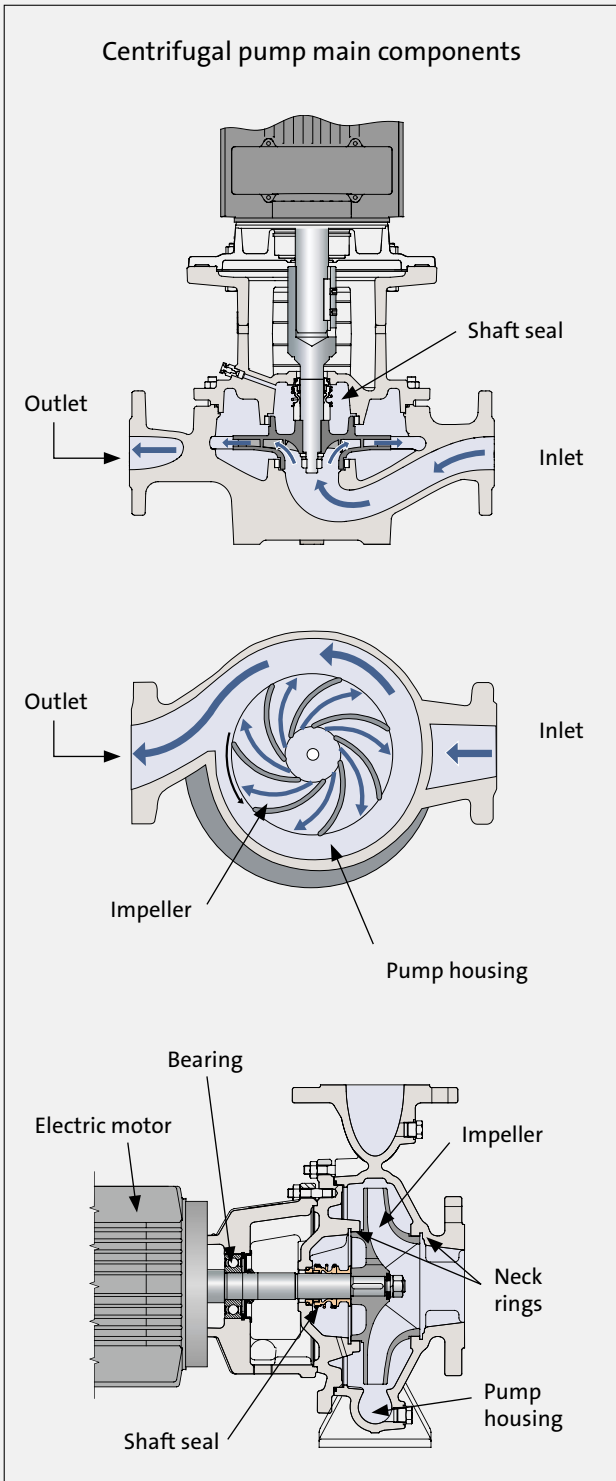

In-line multi-stage centrifugal pump

• **RADIAL FLOW, MIXED FLOW AND AXIAL FLOW PUMPS**

Impeller types for different pressure and flow:

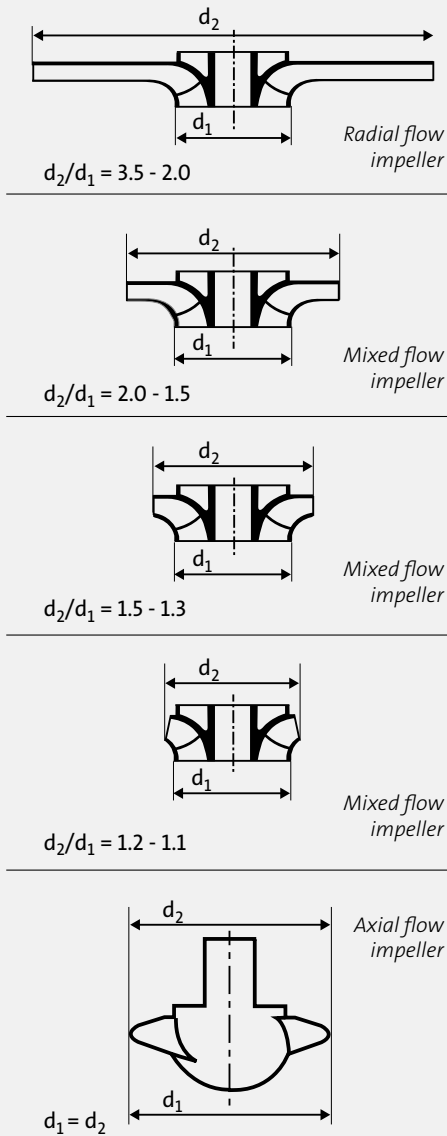

The impeller at the top of the figure shows a radial flow impeller, capable of generating a high pressure. The impeller at the bottom shows an axial flow impeller that can generate a high flow. The impellers in between are called mixed flow impellers, or semi axial flow impellers, or semi radial flow impellers.

• **SURFACE/DRY INSTALLED PUMPS AND SUBMERSIBLE PUMPS**

Usually a pump is installed in a dry environment. For outdoor use the motors must have an enclosure class intended for an outdoor environment. These are typically end suction pumps, split case pumps, and so on.

Submersible pumps are pumps with the pump body submerged in the fluid it is supposed to pump and there are two basic types, both for deep well applications:

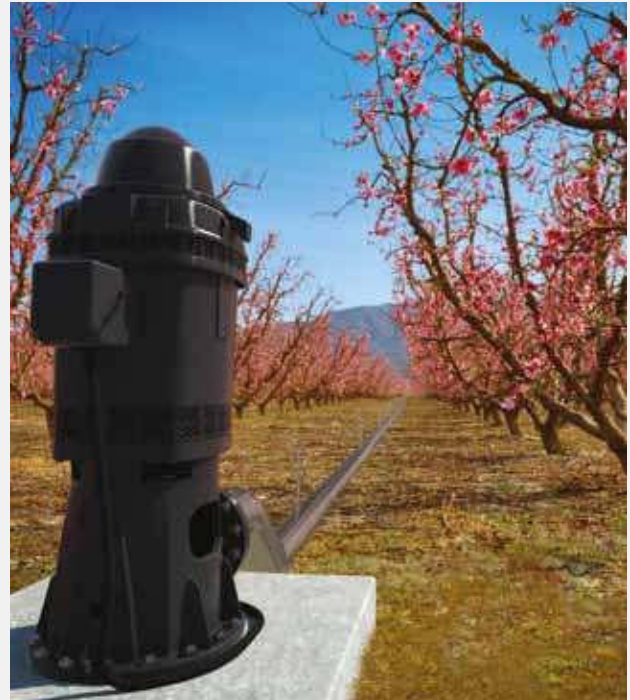

Electric motor for a VT pump.

Vertical turbine (VT) pumps have the pump body submerged in the fluid, but the motor is installed above ground and connected to the pump body with a long shaft, the line shaft.

Submersible pumps, also called **deep-well submersible pumps**, have typically the same pump body as the VT pumps, but the motor is a special design and installed beneath the pump. The submersible motor has been designed to operate in water under high pressure.

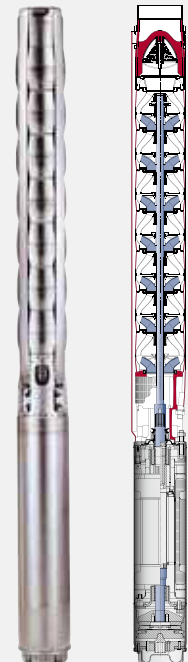

CAVITATION

Cavitation is a phenomenon caused by the water boiling. As described earlier, the water will boil at temperatures lower than 100° C, if the pressure drops below 1 atm. Cavitation can be heard as a loud noise and vibration, and it is devastating for the pump.

However, it is not the water boiling that does the damage. It is when the water is changing its state from vapor to water that the damage occurs. The vapor bubbles in the water implode causing noise, and followed by a heavy mechanical impact, which will destroy the pump if cavitation takes place over an extended period.

PUMP PERFORMANCE

A pump's performance is typically illustrated through a set of curves, or tables, which show the most important data as a function of the flow.

HEAD

A pump delivers flow and head, or pressure. The relation between flow and head is shown in the pump curve below.

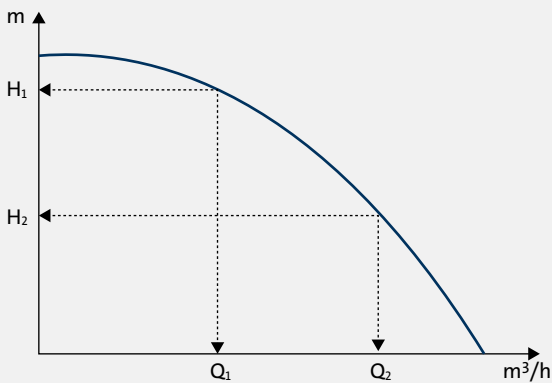

The duty point of the pump is typically a fixed flow and head. From the pump curve the corresponding flow and head can be read. A certain flow Q_1 will give a corresponding pressure H_1 , and the flow Q_2 will give the pressure H_2 . The pump can operate from zero flow (and max head) to max flow (and zero head). However, both extremes must be avoided for several reasons.

PUMP EFFICIENCY

Pump efficiency is a term for how effective the pump is converting the absorbed energy to hydraulic energy. The higher efficiency a pump has, the lower its energy consumption.

A typical efficiency curve is shown below. The curve has a maximum point, which is typically the pump's duty point. In the example below the duty point is at $165 \text{ m}^3/\text{h}$. As soon as the flow is changed to either more or less, the efficiency of the pump goes down, and it drops to zero at both ends.

Operation outside bold line limits ($75 \text{ m}^3/\text{h}$ and $215 \text{ m}^3/\text{h}$) is not recommended.

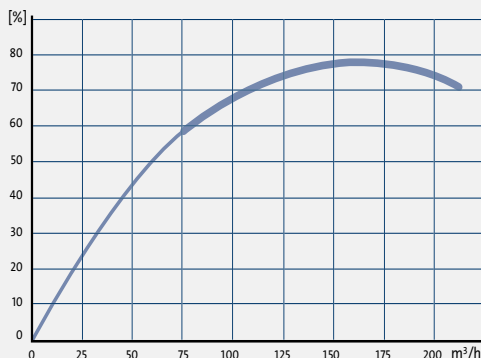

POWER CURVES

The power curve below shows the hp or kW consumption for the pump hydraulic. This is the required shaft power or motor size. On the curve below the maximum kW is 105, which is the shaft power the motor must deliver. Minimum motor size is in this case therefore 110 kW.

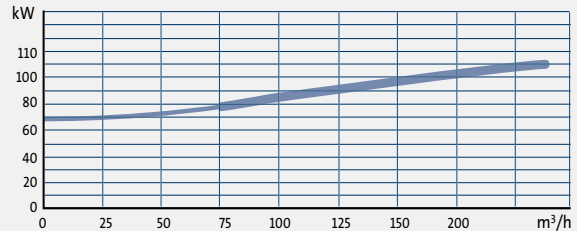

NET POSITIVE SUCTION HEAD, NPSH

Net Positive Suction Head (NPSH) is used as a suction pressure safety limit, in order to avoid cavitation. When the water enters the impeller of a pump there is often already a vacuum, P_1 .

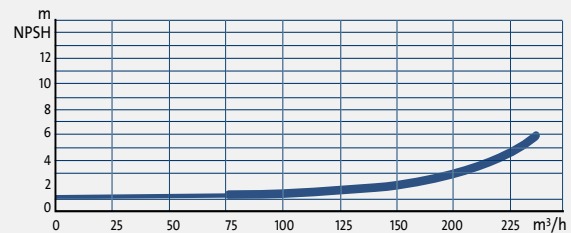

When the water exits the impeller the pressure has increased significantly, P_2 . That is the nature of the impeller. But inside the pump impeller, between the inlet and the outlet, the pressure will actually drop even further, depending on the design of the pump.

As described earlier, the situation where the lowest pressure is lower than the vapor pressure will cause cavitation and thereby destruction of the pump. How to compensate for this and avoid cavitation is by increasing the inlet pressure P_1 .

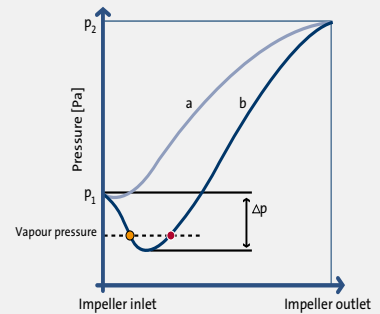

There are several ways to do that:

- lower the inlet and reduce the suction lift
- reduce friction loss in the suction pipe
- reduce the flow
- lift the suction water level

Pumps at work, system curve

A pump is always part of a bigger system, such as an irrigation system. That means there is a pipe most often entering the pump (inlet pipe or suction pipe), and there is always a pipe going out of the pump (outlet pipe or discharge pipe). Friction loss occurs in the pipes, and in the piping system there are often elbows, tee's, valves, filters, and so on, all of which adds friction to the water flow. The friction loss increases with the flow in the 2nd power.

Each pumping system or irrigation system has a unique system curve, which is constant, as long as the friction is not changed, for instance by using a valve, which increases or reduces the flow. In the figure below the usual pump curves (blue) is shown together with the system curve (red).

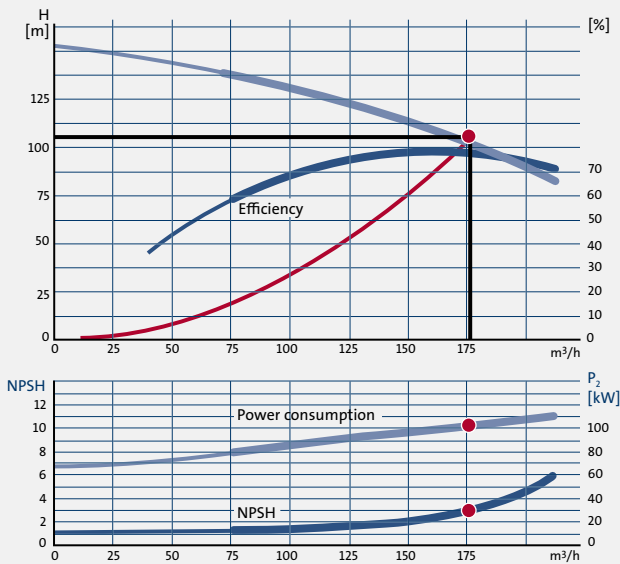

The system curve by definition starts at zero and goes through the pump's duty point on the pump curve. It is used to better understand what will happen when we are trying to regulate the performance of the pump.

The definition mentioned above is different when the pump has a static lift, as shown below.

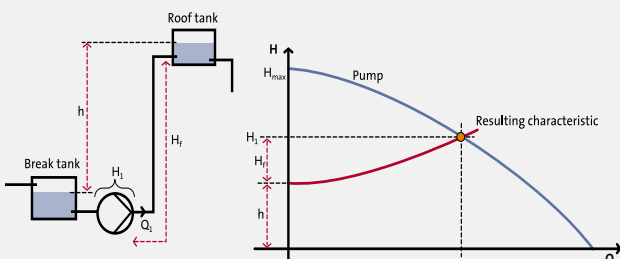

In those situations the zero point starts on the y-axis at the head h , which is the static lift of the water. These situations always apply when deep-well submersible pumps or turbine pumps are used.

PERFORMANCE REGULATION

The performance of pumps can be regulated in several ways. The most common approaches for centrifugal pumps are throttling, operation in parallel, operation in series, bypass control, modifying impeller diameter, change of impeller and change of speed. Not all these approaches are necessarily advisable, as discussed below.

Throttling

- Throttling increases the friction in a pumping system and raises the system curve to a higher position. Energy consumption is typically the same as before throttling, but with a reduced flow.
- This approach for performance regulation wastes energy. The same performance could have been obtained with a smaller pump.

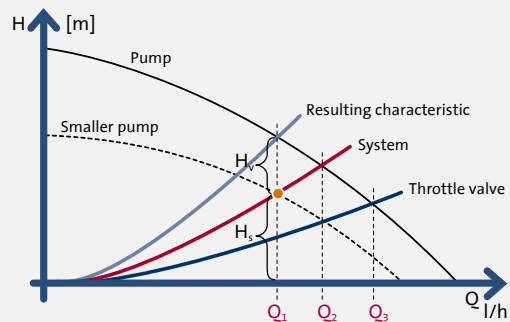
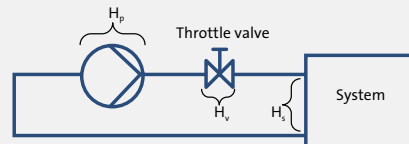

Operation of two pumps in parallel

Two pumps of the same size will perform as shown in the curve below. The total head will be the same as for one pump, while the flow is increasing to the double at zero head. The regulation is done by turning one or two pumps on or off.

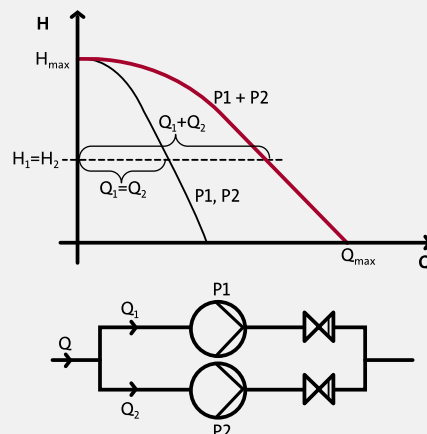

This is a good approach for an irrigation system, where the layout has several zones that are not always used at the same time.

Operation of two pumps in series

Two pumps of the same size will perform as shown in the curve below. The total flow will be the same as for one pump, while the pressure is increasing to the double at zero flow.

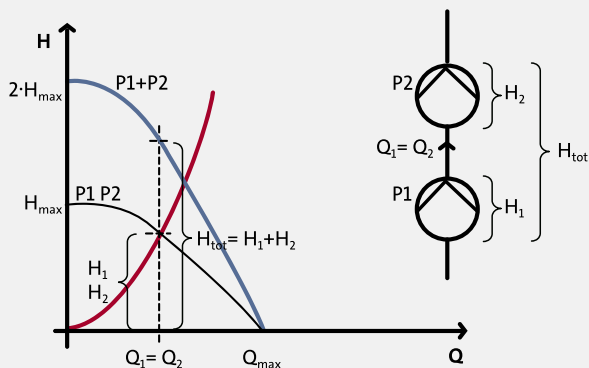

Two pumps in series work as a multi-stage pump with two stages. By adding stages, each stage is contributing with a certain pressure to the total and very high pressure can be obtained. A good example is deep-well submersible or turbine pumps, which are always multi-stage pumps.

Bypass control

Bypass control reduces resistance in the system thus reducing the system curve, and ensures a certain minimum flow through the pump.

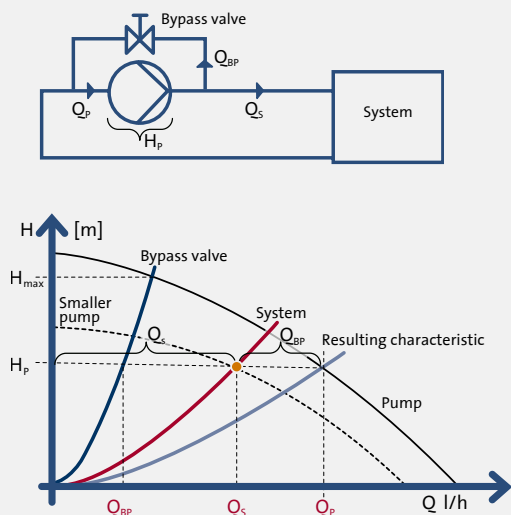

Energy consumption is typically the same for the pump, but since some of the water is recirculated, the overall efficiency of the system goes down.

Modifying impeller diameter

If the pump is giving too much pressure or flow the diameter of the pump impeller can be reduced without any major consequences. The reduction is done by machining, and is fairly costly. When the diameter is reduced the flow, head and power is affected the following ways:

$$\frac{Q_n}{Q_x} = \left(\frac{D_n}{D_x}\right)^2 \quad \frac{P_n}{P_x} = \left(\frac{D_n}{D_x}\right)^4$$

$$\frac{H_n}{H_x} = \left(\frac{D_n}{D_x}\right)^2 \quad \frac{\eta_n}{\eta_x} = 1$$

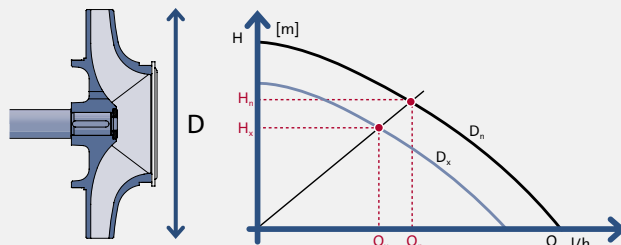

On the curve to the right is shown the change in flow and head.

Change of impeller

Instead of machining the impeller smaller, some pump companies manufacture and offer smaller diameter impellers intended to reduce the head of a full size impeller. These impellers are designed to meet a specific lower duty point and will always match the rest of the pump.

Speed regulation

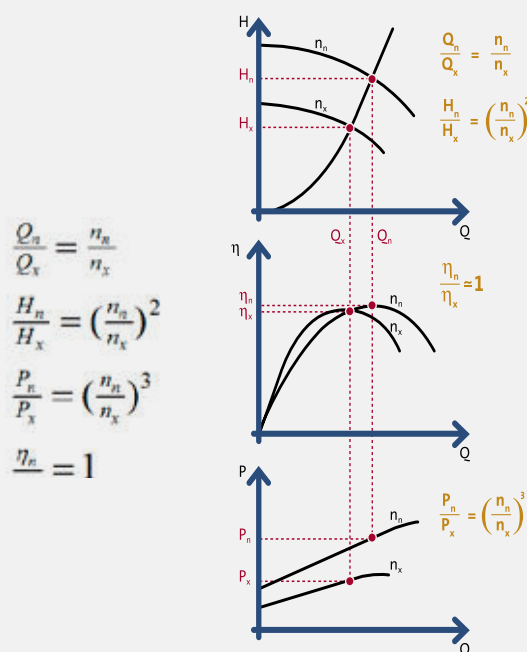

Variation of the pump speed, or rpm, is the most effective way to regulate a pumps performance. When the speed is changed the parameters changes as shown below:



The use of variable frequency drives (VFD) is becoming increasingly popular as an effective tool to vary the speed of a pump and thereby the pump performance. One of the major benefits of this type of regulation is that the efficiency remains more or less unchanged over a wide performance range. This gives significant energy savings by reduced speed.

Comparison of performance regulation

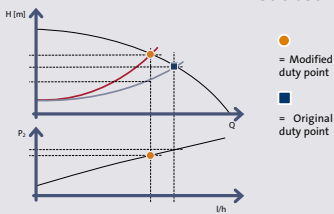
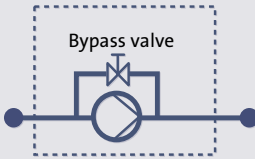
The chart below shows the main differences between the various approaches to pump performance regulation.

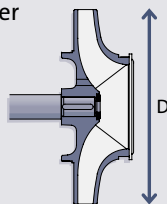
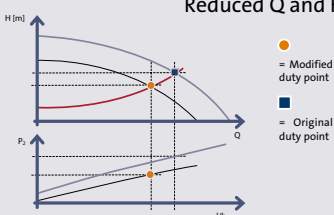
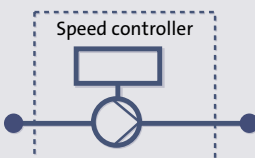
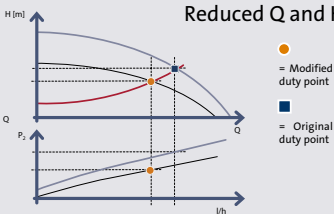
Method	Continuous adjustment possible?	The resulting performance curve will have	Overall efficiency of the pump system	Relative power consumption by 20% reduction in flow
Throttle control 	Yes	Reduced Q 	Considerably reduced	94%
Bypass control 	Yes	Reduced H and changed curve 	Considerably reduced	110%
Modifying impeller diameter 	No	Reduced Q and H 	Slightly reduced	67%
Speed control 	Yes	Reduced Q and H 	Slightly reduced	65%

ELECTRIC MOTORS

An electric motor converts electrical power to mechanical power.

Motor components

An electric motor has a stationary part, the stator, and a rotating part, the rotor. The stator is built of laminated steel plates with slots on the inner diameter, in which are inserted copper wire. The rotor is also built of laminated steel plates with slots or holes on the outer diameter in which are inserted copper or aluminum bars.

An electric field induced in the stator forces the rotor to rotate.

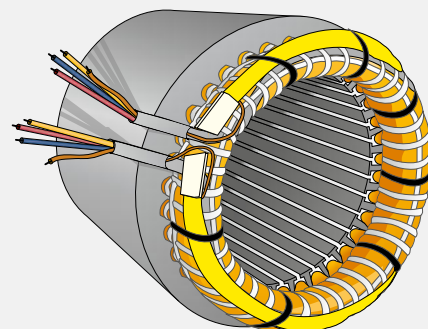

Power considerations and efficiencies

Electric motors convert electrical energy into mechanical energy, which is used to drive the pump.

P_1 is the energy consumed by the motor. This can be read on the meter, and is the amount of energy the power company is charging for.

P_2 is the motor shaft power, and this number is always lower than P_1 , because there is a certain electrical loss in the windings, and some mechanical friction losses. P_2 is also referred to as motor size. 'How big is your motor?' means: how much is your P_2 of the motor?

The ratio between P_2 and P_1 is the motor efficiency, $\frac{P_2}{P_1} \times 100\%$ where both P_1 and P_2 are in W or kW or hp.

If the motor size is listed in hp, the formula for motor efficiency is $\frac{P_2 \times 0,746}{P_1} \times 100\%$. P_2 is now in hp and P_1 is in kW.

P_3 is the shaft power input required to drive the pump and is usually the same as P_2 . But in cases where pumps have a long shaft such as a vertical turbine pump, the friction in the long shaft bearing can be significant, and P_3 is therefore lower than P_2 .

P_{hyd} , or P_4 , is the hydraulic power. This is the energy that comes out of the pump as a product of head and flow.

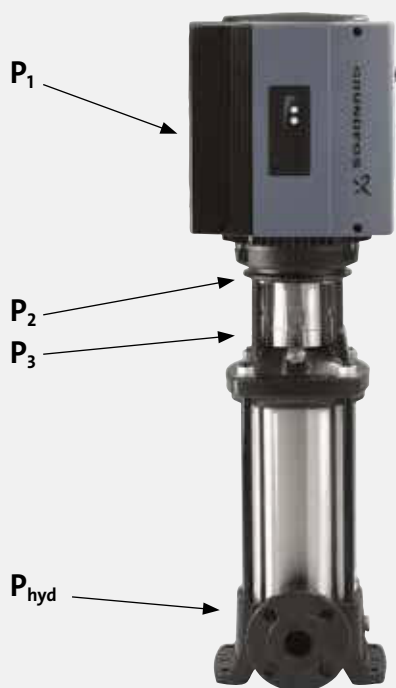

MOTOR PROTECTION

In order to avoid unexpected breakdowns, costly repairs and subsequent losses due to motor downtime, it is important that the motor is fitted with some sort of protective device.



For external protection against short circuits in the whole installation, external protection devices are normally different types of fuses or short circuit relays. This kind of protection device is compulsory and legal and placed under safety regulations.

External protection against overload of specific equipment is important to avoid the overload of the pump motor and thereby prevent damage and breakdown of the motor. This type of protection reacts on current.

Built-in motor protection with thermal overload-protection avoids damage and breakdown of motor. The built-in protector always requires an external circuit breaker, while some built-in motor protection types even require an overload relay.

What to protect against

Problems with the power supply quality can be issues such as overvoltage, undervoltage, imbalanced voltages/currents and frequency variation.

Installation, supply and motor failures should of course be avoided and usually result from either slow or rapid temperature increases in the motor windings.

In cases of slowly-developing temperature increases, causes can be:

- Insufficient cooling
- High ambient temperature
- High altitude operation
- High liquid temperature
- Too high viscosity of the pumping liquid
- Frequent starts
- Too big load inertia (not common for pumps)

In cases of quickly-developing temperature (less than one minute from ambient temperature to breakdown), causes can be:

- Locked rotor
- Phase breakage

Fuses and circuit breakers

Fuses:

- Fuses prevent short circuits from damaging the installation and in worst case causing a fire.
- It is essential that the fuse trips out before thermal damage of other parts of the installation occur because of short circuits.

Overload relays:

- Make it possible for the motor to handle harmless temporary overloads without interrupting the circuit, i.e. motor starting.
- Trip and open a motor circuit, if the current exceeds its limits and might damage the motor. Are reset either automatically or manually once the overload situation has passed.

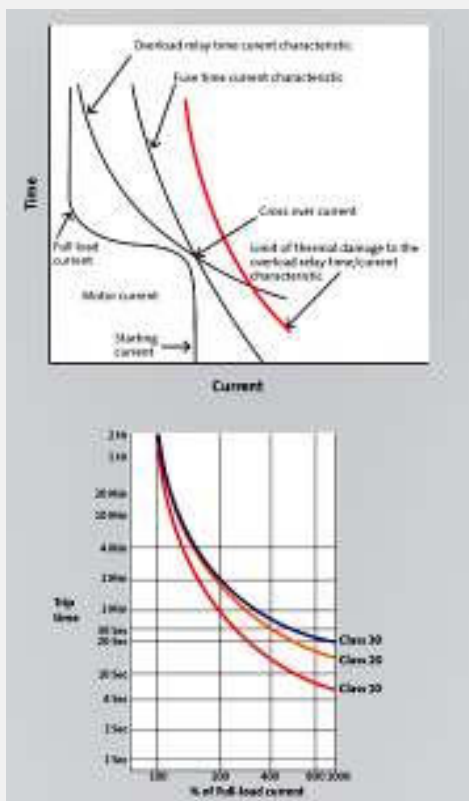

Dedicated pump protection devices

Motor protection offers surveillance of the motor as well as protection. Shown below is an example of a dedicated pump protection device, the Grundfos MP204, with the parameters for monitoring and protection listed.

The monitored data can be transmitted to a central controller, which can then control the pump. This device can be used on any AC electric motor up to 999A, or approximately 700 hp depending on the voltage.



Monitoring	Insulation resistance
	Motor temperature incl. PT and PTC
	Current true RMS
	Current unbalance
	Voltage, true RMS
	Power consumption
	Phase sequence
	Harmonic distortion
	Power factor
	1-ph start and run capacitors
	Operating hours, since reset and accumulated
	Number of starts, since reset and accumulated
Protection	Energy consumption, kWh, since reset and accumulated
	Heat
	Underload/dry run
	Over voltage
	Under voltage
	Phase unbalance/loss
Overload	
Faulty capacitors	

GROUNDWATER WELLS

78



12

12

PUMP SIZING

PUMP SIZING IS ABOUT SELECTING THE RIGHT PUMP WITH THE HIGHEST EFFICIENCY FOR THE OPERATING CONDITIONS REQUIRED FOR THE APPLICATION. TO GET THE RELEVANT DATA FOR THE OPERATING CONDITIONS:

1. CALCULATE HOW MUCH FLOW IS NEEDED FROM THE PUMP
2. CALCULATE HOW MUCH HOW MUCH PRESSURE THE PUMP MUST GENERATE.

PUMP SIZING

The pump supplier will normally select a pump with the highest efficiency for the operating conditions. To find out if the operating conditions are stable, the process for calculating the relevant data is as follows:

1. Calculate how much flow is needed from the pump

Determine the amount of water to be applied during the peak period. This can be calculated from the size of the field, and how many mm of water that must be applied. The result is then converted to cubic meters per hour (m³/h). This number is the minimum size of the pump.

As an example, say we want to grow sweet corn on a 20 hectare field. The water is coming from a well. A pump with best efficiency at 106 m³/h could (see calculation below). If that pump is chosen, it should pump 24 hours a day.

To allow for system downtime and power cost windows a larger pump will therefore always be chosen, and a runtime of between 12 and 18 hours per day is typical.

If we choose 12 hours runtime per day the pump must be able to pump the double amount: 212 m³/h. The Grundfos submersible pump type SP215 can give 212 m³/h, which is close to where the maximum efficiency is, and this pump is therefore selected (see curve below).

The calculation:

ETP in the area for sweet corn is 11.4 mm per day.

Crop efficiency $K_c = 1$

Water loss and water used by crop is: $ETP \times K_c$ – in this case $11.4 \times 1 = 11.4$ mm/day.

Let's assume irrigation efficiency is 90%.

Required per day is then a bit more: $\frac{11.4}{90} \times 100 = 12.7$ mm/day.

1 ha = 10,000 m².

Per hektar it is therefore necessary to apply $10,000 \times 0.0127 \text{ m}^3 = 127 \text{ m}^3/\text{day}$.

The 20 ha field therefore needs $20 \times 127 \text{ m}^3 = 2540 \text{ m}^3/\text{day}$.

That is the same as 106 m³/h.

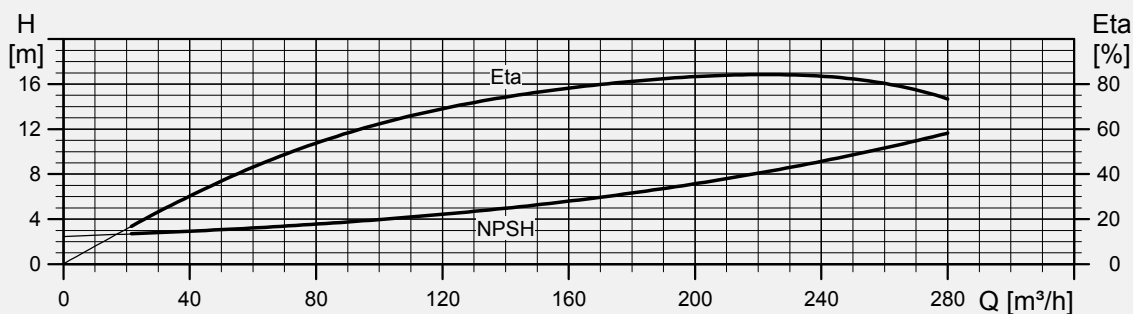

Efficiency and NPSH curves for the Grundfos submersible pump type 1100S. The pump's nameplate typically notes the pump's flow at best efficiency. Another number typically refers to the number of bowls and thereby how much pressure the pump can produce.

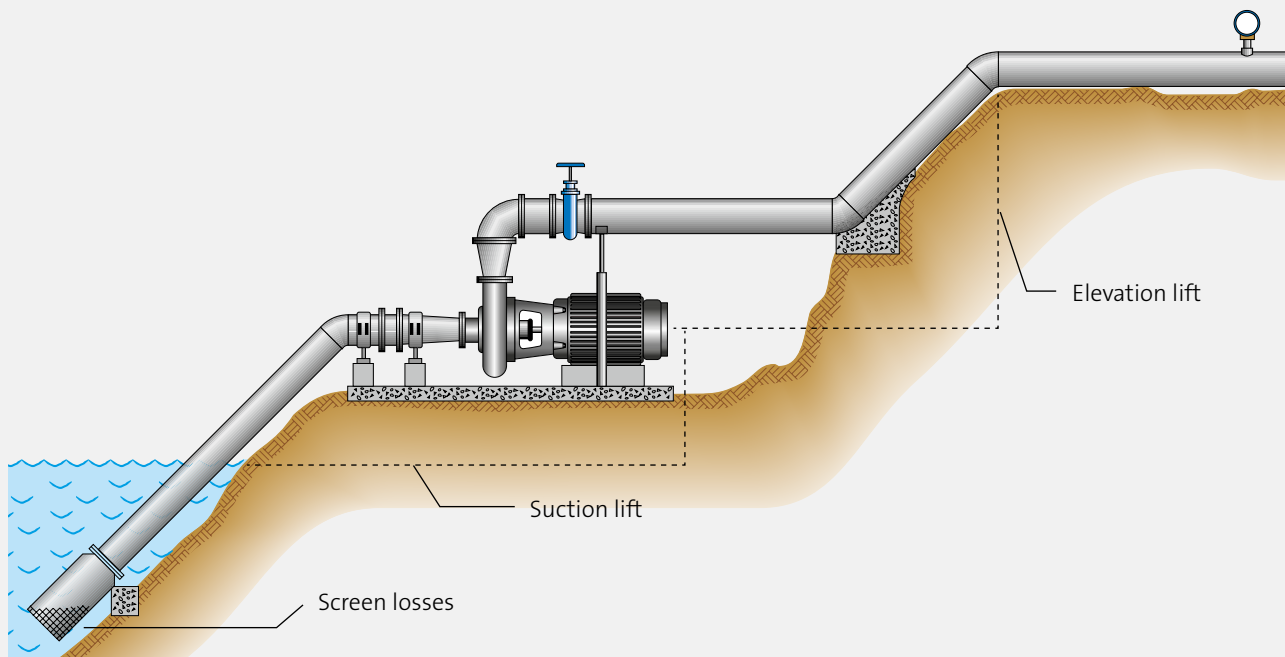

2. Calculate how much head the pump must produce

An irrigation pump has to overcome four elements of pressure:

- Pressure needed for the application devices (sprinklers, spray heads, drippers, and so on)
- Friction loss in the piping system, pipes, screens, valves, elbow's, tee's, and so on
- Elevation lift
- Suction lift

For a deep-well pump, such as a submersible or a vertical turbine, another consideration is the drawdown of the static water level. The static water level is defined as the depth to water when no water is being pumped from the well.

As soon as the pump starts pumping, the water level will start to go down. The water level will continue to go down until equilibrium is reached, and that is when the friction loss in the aquifer and the casing screen (meter of friction) is the same as the drawdown (meter of head). The dynamic water level is defined as the depth to water when the pump is running at its operating capacity.

When the total head for a ground water pump is calculated, two things are different from a surface pump:

1. there is no suction lift
2. the drawdown has to be added to the elevation lift

The other components in the calculation are unchanged.

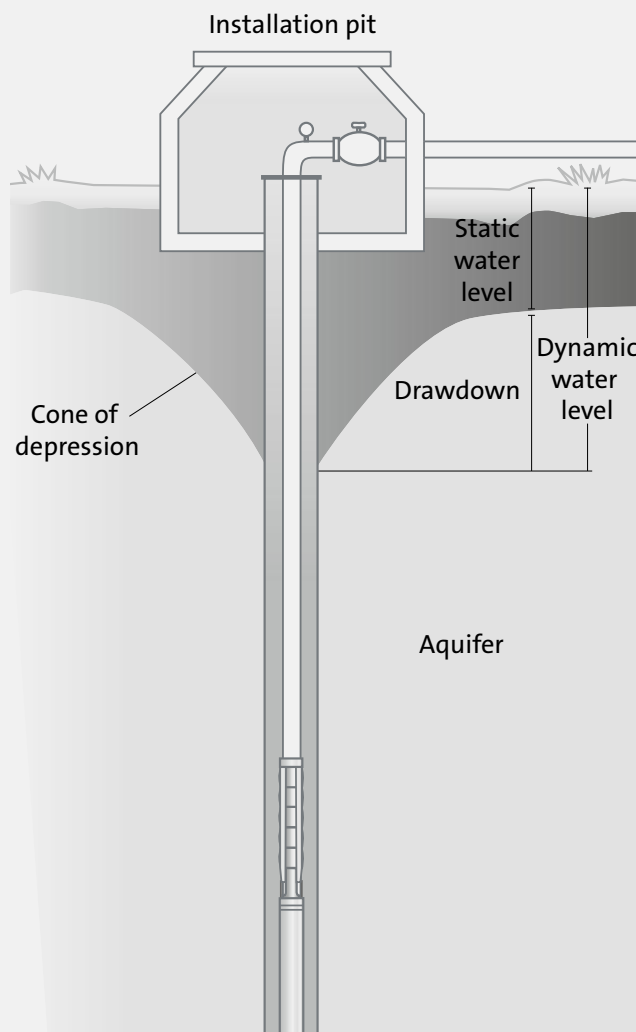

Let's return to the calculation and calculate the required head the pump must produce. Let's assume

- the application device use 0.5 bar of pressure or 5 m head
- the friction loss in the pipes, elbows, valves and tee's has been calculated to 2.5 bar, or 25 m head
- let's assume the elevation lift is only 20 m head
- Static water level is 50 m (this corresponds to suction lift for a surface pump)
- the drawdown in the well is 3 m
- Total head requirement to the pump is therefore $5+25+20+50+3=103$ m.

We earlier calculated the flow and found a Grundfos submersible pump SP215 meets this requirement. Looking at the pump performance curves we can see that a 4 stage pump can meet the head requirement of 103 m.

The pump curve below shows that a 4 stage pump will give exactly the flow and head required. The pump is a submersible pump, type SP215-4 (4 stages or bowls) with a 75 kW motor.

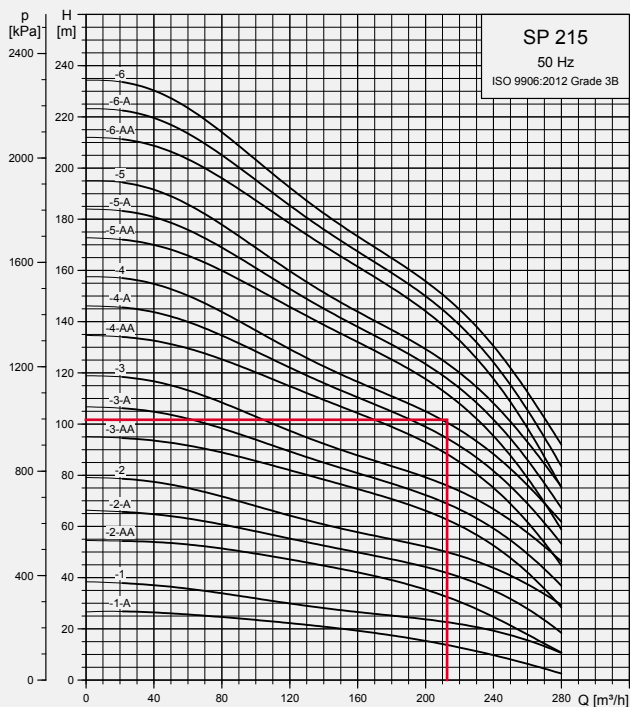

In this example the performance requirement was right on one of the curves. Let's assume that the head requirement had only been 100 m. In that case there is no curve matching the duty point, which is between two curves.

The solution is to select one of the two curves: if the upper curve is selected there is a bit more reserve in the pump, if the

lower one is selected the pump will run marginally for a longer time. In both cases it has no practical influence on the performance or the efficiency, which can be seen from the efficiency curve.

GROUNDWATER WELLS

A well is an opening stretching from the ground surface to the underground aquifer, where the groundwater is located. The depth of the well may vary from a few meters to several hundred meters.

Wells are typically drilled with special drilling equipment able to penetrate the various layers of the ground, such as sand, clay, bedrock, and the like. Inside the drilled hole a casing (pipe) is typically installed, which prevents the well from collapsing around the pump.

Below the casing and in line with the aquifer is another 'casing' with fine slots. This is the well screen, where the slots allow the water to enter the well. It holds back sand and larger particles trying to enter the well.

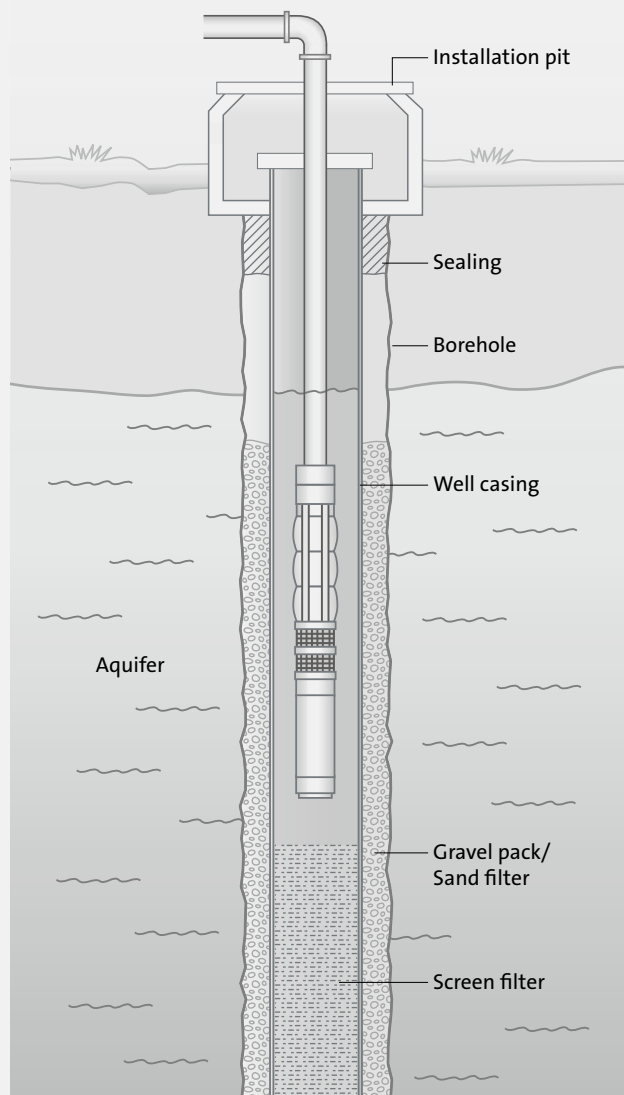

To improve the filtering function, the borehole typically features a diameter that is 2-3" larger than the casing. A fine sand gravel pack filter is placed between the casing and the aquifer. Some casings come with a pre-made gravel pack filter. Made correctly, this filtering method prevents sand and silt from entering the well.

The US EPA and National Water Works Association are recommending the following sand limits in well water:

- 1 ppm in water for drip and microspray application.
- 10 ppm in water for sprinkler irrigation systems.
- 15 ppm in water for flood irrigation.

Before the well can be put into operation, it must be developed. A new well will always produce some sand and silt in the beginning, and well development is the process of pumping a new well free from sand and silt. It is done by pumping with a very high flow, which draws the fine particles in the aquifer into the filter of the well. This slowly makes the filter more effective. After approximately one day of pumping, the well is normally pumped clean, and is ready for normal operation.

The pump used for well development wears out relatively quickly because of the high sand content, and it should therefore always be replaced with a new pump as soon as the well does not produce any more sand.

The submersible pump must always be installed above the screen area of the casing. This is to ensure that the water is forced past the motor, providing adequate motor cooling. If the pump cannot be installed above the screen filter, a cooling sleeve is recommended to create the necessary flow along the motor for proper cooling.

The drawdown for each specific well can be tested using a test pump with the same flow rating as the production pump, which is installed in the well and the pump started. The groundwater level is recorded, and the equilibrium point has been reached when the water level has become constant. This level is the dynamic water level. The drawdown is the difference between the static and the dynamic water level.

All the water the well is producing is pushed through the aquifer and the well screen by the pressure differential there is between the static and the dynamic water level. The higher the flow is, the bigger the drawdown will be. For this reason it is often better, considering operating costs, to use two or more smaller pumps (and wells) instead of one large one. With smaller pumps the drawdown is limited, and the elevation lift is reduced.

Some aquifers have so much resistance that the water flow to one well is not enough to cope with the irrigation need. A second and third well may be the only solution to get the amount of water required.





13

13

PUMP PERFORMANCE

TO MAINTAIN PUMP PERFORMANCE AT THE HIGHEST EFFICIENCIES, IT IS HIGHLY RECOMMENDED TO MONITOR THE PUMP PERFORMANCE. FROM THIS, THE PUMP EFFICIENCY CAN BE CALCULATED.

PUMP PERFORMANCE

Maintaining pump performance is fairly simple and requires monitoring of just three parameters:

1. flow
2. pressure
3. power consumption

From the three parameters the pump efficiency can be calculated:

$$\text{Pump efficiency } \eta = \frac{H \times Q}{367 \times P_1}$$

where

- H is the pump head in meters (m)
- Q is the flow in cubic meters per hour (m³/h)
- P₁ is the motor power consumption in kilowatts (kW)

Please note that the formula above calculates both motor and pump-end efficiency as one total number. A comparison with the pump literature can therefore not be made, as this data is pumps-only efficiencies.

When checking the pressure, remember to add the elevation lift and friction loss from the discharge to the gauge, if the pressure gauge is not installed directly at the pump discharge. This must always be done for a deep well pump.

If these parameters are recorded right after the pump has been installed, they can be checked at regular intervals, or even better, with on-line monitoring equipment that can be set to give alarms if some of the parameters are changing, or exceeding a pre-set limit.

If deviations from the pre-set conditions occur there are typically three main reasons why:

1) The pump's operating conditions have changed

For example, if the water table in a well drops and the pump has to deliver a bigger head; the duty point is actually moving to the left on the pump curve. Perhaps a valve in the system is throttling more or less than previously. If the conditions could be changed back, they should. If not, installing another pump should be considered.

2) The water or pressure requirements have changed

If another section of irrigated land has been added, or taken out, or the flow requirements have changed significantly, a change of pump must be considered; also if the irrigation system has been changed to a less water consuming application.

3) The pump is losing efficiency and needs repair or replacement

Pumps losing efficiency typically occur for the following reasons:

• Cavitation

For more information about cavitation, please see chapter 11.

• Water hammer

Water hammer is a problem that can occur when water is flowing in a pipe and a valve is closed too quickly. The longer the pipe, the worse the impact; and water hammer happens because water cannot be compressed. This can be compared with a long train in motion, which also needs some time to come to a complete stop. If it is forced to stop in a split second it destroys itself and everything that is trying to stop it.

When water hammer happens it can be identified as a loud noise, as when someone is hammering on the pipes. Water hammer can destroy both the pump, pipes, valves and other components in the system.

A way to avoid water hammer is by introducing an air buffer somewhere in the pipeline. This could be a pressure tank containing air, and since air is compressible the energy in the flowing water can be absorbed by the air volume. Another way to avoid water hammer is to introduce a soft start and stop of the pump. If the pump is equipped with a variable frequency drive (VFD), it will also have a soft start and probably also a soft stop. Since VFDs are good for general pump performance regulation, it is the recommended approach to avoid water hammer.

• Wear from sand and other abrasive materials in the water

Sand will over time destroy the pump completely, and already from very early in the process a loss of efficiency can be seen. A deep well designed correctly will not produce sand of significant quantities. But in many cases the well has not been made properly, and it will continue to produce sand for as long as it is in use. In such cases, the only way to avoid sand entering the pump is effective filtering before the pump inlet.

- **Bad Power Supply**

A bad power supply may destroy the electric motor.

- over voltage or in particular under voltage above + / - 10%
- phase unbalance with more than 3% deviation between phase voltage
- voltage spikes from other equipment starting and stopping, and in particular from lightning.

Grundfos offers a special overload device that takes care of all of the above.

- **High temperatures**

High temperatures can occur because of too high ambient temperatures, or because the cooling is not good enough. Electric motors normally have their maximum ambient temperature shown on the nameplate. Make sure that is not exceeded and that the motor can get rid of the heat generated.

Submersible pump motors are cooled by the water that is being pumped, and if that water is not removed quickly enough it will slowly heat up and exceed the maximum allowable temperature for that motor.

Some motors come with built in temperature sensors which will stop the motor whenever a pre-set temperature has been exceeded. Others require a separate signal wire is to transmit the temperature signal to a temperature overload device. Grundfos submersible motors have a built-in temperature transmitter that sends a signal to an above-ground protection device with no extra wires, thus making the installation very simple.

For more details see Chapter 11.

- **General overload**

A general overload of the pump and motor will cause the temperature in the motor to increase and eventually destroy the motor. It is therefore important always to install a good overload device, such as the MP204 described in chapter 10 above. This device will protect against all the possible disturbances that may occur, including overload.



TECHNICAL OVERVIEW	86
RANGE OVERVIEW	87



14



PUMP OVERVIEW

GRUNDFOS CAN SUPPLY PUMPS FOR ANY WATER SOURCE AND FOR DOSING AND DISINFECTION APPLICATIONS, AS WELL AS VARIABLE SPEED DRIVES AND INTELLIGENT MONITORING, CONTROL AND REMOTE MANAGEMENT SOLUTIONS.

Technical Overview:

SP	Submersible pumps Flow, Q: max 460 m ³ /h Head, H: max 650 m Power: max 250 kW	DME	Digital Dosing Pumps Flow, Q: 0.075 – 940 l/h Head, H: max 10 bar
Peerless VTP	Vertical turbine pumps for deep wells Flow, Q: 22.700 m ³ /h Head, H: 700 m Power: max	CRFlex	Solar powered multistage pumps Flow, Q: 140 m ³ /day Head, H: 150 m
Peerless MF	Vertical axial and mixed flow pumps Flow, Q: 2000 m ³ /h Head, H: 700 m Power: max	SP/SQFlex	Solar powered submersible pumps Flow, Q: 670 m ³ /day Head, H: 500 m
CM, CME	Horizontal multi stage pumps Flow, Q: max 30 m ³ /h Head, H: max 100 m Power: max 7.5 kW	Solar Panels	Power generation for CRFlex and SQFlex max 11 kW
CR, CRE	Vertical multi stage pumps Flow, Q: max 180 m ³ /h Head, H: max 280 m Power: max 75 kW	Wind Turbine	Power generation for CRFlex and SQFlex max 1 kW
Hydro MPC	Packaged Booster Pump System Flow, Q: 720 m ³ /h Head, H: 160 m/450 m Power: max 75 kW	IO100, IO101, IO102	Input / output modules for Flex products
EGB	End Gun Booster pump Flow, Q: max 68 m ³ /h Head, H: max 20 m Power: max 4 kW	CU 200	Control Box for Flex products
NK/NB	End suction pumps Flow, Q: max 1200 m ³ /h Head, H: max 150 m Power: max 355 kW	MP204	Motor protection against all external power disturbances, and data monitoring
HS	Horizontal Split Case pumps Flow, Q: max 2500 m ³ /h Head, H: max 150 m Power: max 630 kW	CUE	Frequency Converter specially designed for pump control Power: 1 – 250 kW
DDA, DDC, DDE	Smart Digital Dosing Pumps Flow, Q: 0.0025 – 30 l/h Head, H: max 16 bar	CU351/2	1 – 6 pump controller with integrated start up wizard for easy commissioning of the system
		CIU 271	Data Communication interface used with Grundfos Remote Management

Range Overview:

PUMPS

Groundwater Pumps



SP
Submersible Pump



Peerless VTP
Vertical Turbine Pump



Peerless MF
Axial and Mixed Flow Pump

Surface Pumps



CME
Horizontal Multi-Stage Pump



CRE
In-Line Pump



Hydro MPC
Pressure Boosting System

Surface Pumps



EGB
End Gun Booster Pump



NB
End-Suction Pump



NK
End-Suction Pump



HS
Split-Case Pump

Dosing Pumps



DDA, DDC, DDE
SMART Digital Dosing Pumps



DME
Digital Dosing Pump

RENEWABLE PUMPS



CRFlex
In-Line Pump for Renewable Energy



SQFlex
Deep Well Submersible Pump for Renewable Energy



Solar Panels
Power Generation for CRFlex and SQFlex



Wind Turbine
Power Generation for CRFlex and SQFlex



IO100, IO101, IO102
Control Unit



CU200
Control Unit

MOTOR PROTECTION



MP 204
Motor Protection Unit

VARIABLE SPEED DRIVES



CUE
Variable Speed Drives

MONITORING & CONTROLS



CU 351
Control Unit



CIU 271
Grundfos Remote Management (GRM) Communication Interface Unit

AUTOMATION AND INTELLIGENCE	90
THE INCREASING IMPORTANCE OF THE PUMP	90



15

15

THE FUTURE – SUSTAINABLE AGRICULTURE

INTELLIGENT TECHNOLOGIES THAT MAKE IRRIGATION MORE EFFICIENT ACROSS THE BOARD ARE HELPING FARMERS MEET FUTURE CHALLENGES OF POPULATION GROWTH AND FOOD PRODUCTION.

THE FUTURE – SUSTAINABLE AGRICULTURE

Water and energy management are urgent issues facing an increasingly urbanised world, not least for irrigation and food production. Complexity is increasing for irrigation applications, with greater demands for reducing energy consumption, protecting the water source, reducing the CO₂ footprint and integrating of all aspects of the pumping solution.

In 2050, the world population is estimated to be nine billion. By then, the urban population is estimated to almost double from 3.4 billion today to 6.4 billion. This will further increase the pressure on our limited water resources that are already stressed today. Managing the water source is not only a question of more mouths to feed; people today consume more calories and eat more meat, and this requires more water to produce food.

There is a need for intelligent technologies that reduce water usage and energy consumption, manage the water source, and make irrigation more efficient across the board. To meet the challenges of population growth and food production in the future, agriculture must become more sustainable while maintaining profitability for the farmer.

THE CHALLENGE IS FOR AGRICULTURE TO BECOME **MORE SUSTAINABLE** WHILE MAINTAINING PROFITABILITY FOR THE FARMER. **INTELLIGENT TECHNOLOGIES** ARE ALREADY HELPING ACHIEVE THIS.

AUTOMATION AND INTELLIGENCE

In agriculture, we see increasing automation involving more sophisticated machinery, more complex data calculations, better water management, and more efficient practices.

It is already possible to use GPS to guide tractors, automatic weeders and robotic slope mowers, and in irrigation GPS is used as trackers on pivots. These machines greatly cut down the cost of labor, and further technology applications could see remote controlled tractors and data tags may be seen in the near future. Devices that examine the land are also becoming more sophis-

ticated. Tools that display the amount of water used, fertiliser applied, crop yield, soil conditions, weather patterns, and crop topography are already being used. Equipment includes dosing pumps, soil topography maps, and soil moisture sensors. However, the interpretation of the data is still being done by human experts. Eventually, all of the data will be put together, the analyses will be executed by a computer, and the computer will tell the farmer how to alter routines in order to produce a greater yield.

Better resource management and therefore more efficient practices means the use of less water and pesticides applied more sustainably. In the future, environmental rules will probably become stricter. Water intake, treatment, distribution, and pesticide application will be monitored more closely. Regulations on tailwater and water sources being used will also continue to increase. Farmers ought to begin managing their resources more carefully now, so that increasing regulation of tailwater and water sources will be easier to meet when enacted.

THE INCREASING IMPORTANCE OF THE PUMP

Increasingly, the systems that will be used to irrigate a field will be the most efficient system for that field, and the irrigation techniques will become more and more specific to each field. Many consider drip irrigation the perfect system to use in order to conserve resources, because of the reduced amount of water that is delivered to the root zone, resulting in less waste.

However, the type of pump that is used is an important factor in conservation too, and for ensuring that the farmer's irrigation design layout meets the precise requirements for the crop and optimises irrigation efficiency. Pumps should neither over pump nor produce too much pressure. In many cases a variable frequency drive (VFD) should be used to control the pump from using excess water and energy. Pump controls will be integrated with the irrigation controller to make sure they are communicating with each other, and that both are running only when necessary.

These requirements are satisfied if the pump matches the irrigation system, flow pressure is kept low, and controls are used. As we have discussed, the tendency towards integration and automation is increasing, and it won't be long until a whole farming operation can be controlled from a portable device.

From deep-set turbines to surface boosting operations, Grundfos can supply intelligent agricultural pumping solutions for all groundwater and surface water flow requirements. Pumps with variable frequency drives (VFD) take account of changing conditions above and below ground and deliver the right amount of pressure and head at the nozzle. This ensures that energy costs don't eat away at profit margins.

THE TENDENCY
TOWARDS **INTEGRATION**
AND **AUTOMATION** IS
INCREASING, AND IT
WON'T BE LONG UNTIL
A WHOLE FARMING
OPERATION CAN BE
CONTROLLED FROM A
PORTABLE DEVICE.

In a rapidly-developing field, Grundfos is one of the most innovative companies, discovering new ways of doing things and of refining proven successes. Ultimately, Grundfos will continue to raise the standards for irrigation pumping systems to meet the needs of modern, high-potential growers.





16



GLOSSARY

MUCH TERMINOLOGY IS USED IN IRRIGATION.

THE MOST COMMONLY-USED TERMS ARE DEFINED HERE.

GLOSSARY

Much terminology is used in irrigation. The most commonly-used terms are defined here.

Aquifer

A water-bearing soil formation or group of formations having sufficient permeability to yield useable amounts of water to wells.

Axial flow pump

Pump design used for low-head, high flow conditions, also called a propeller pump. This design does not use centrifugal action (see Centrifugal Pump) to move water. Rather it uses the principle of a wedge. Water is physically forced through the pump by the rotating propeller. See page 61.

Booster pump

A pump used for providing a medium to high discharge pressure. Usually used for pumps supplying sprinkler or micro-irrigation systems.

Bowl

The bowl, also called the pump housing, is the stationary part of the pump and often contains guide vanes to convert the rotation energy into pressure.

Bowl efficiency

Efficiency of the pump by itself (as opposed to combination of the pump driver and transmission system). It is difficult to determine bowl efficiency in the field. An estimation can be made by subtracting out other losses associated with the pumping station such as the power plant and transmission efficiencies.

Capacity

The flow rate of a pump. It is generally used when referring to the normal (or required design) flow rate of the pumping station.

Cavitation

The rapid formation and collapse of air bubbles in water as it moves through a pump. This results from too high a vacuum in the pump itself due to insufficient "net positive suction head." Cavitation causes pitting of the impeller and pump housing and can greatly degrade pump performance. See page 61.

Centrifugal pump

A pump in which water enters the center of a rotating impeller and is flung out radially, gaining energy in the process. This is also a term commonly used for a specific type of pump where the impeller is enclosed in a volute casing. A volute casing is a type of casing where the area of water flow increases uniformly

towards the pump discharge. The increase in flow area converts the velocity achieved through centrifugal action into pressure.

Check valve

A valve installed in a pipeline that automatically closes and stops water from flowing backwards when a pump is shut off. This is also called a non return valve

Chemigation

The application of pesticides or system maintenance products through an irrigation system.

Chlorination

Periodic injection of chlorine compounds into wells to prevent the growth of bacteria and slimes. Also used when referring to injection into irrigation systems, most often micro-irrigation systems.

Corrosion

Deterioration and destruction of metal by chemical and/or galvanic reactions. Chemical corrosion dissolves the metal, which is then carried away by the water. Chemical corrosion can allow sand to enter the well. Galvanic corrosion is caused by electrolytic cells forming between dissimilar metals or surfaces.

CO₂ footprints

A carbon footprint has historically been defined as the total set of greenhouse gas (GHG) emissions caused by an organisation, event, product or person. This is typically calculated as a carbon dioxide equivalent (CO₂e), using the relevant 100-year global warming potential. For simplicity of reporting, it is often expressed in terms of the amount of carbon dioxide.

Daily crop water use (evapotranspiration – ET)

This is the net amount of water extracted from the soil daily by the crop and surface evaporation from the soil.

Data bus

This is also called a fieldbus and refers to the family of industrial computer network protocols used for real-time distributed control. An automated industrial system (e.g. a manufacturing assembly line) usually needs an organised hierarchy of controller systems to function. In this hierarchy there is usually a Human Machine Interface (HMI) at the top, where an operator can monitor or operate the system. This is typically linked to a middle layer of programmable logic controllers (PLC) via Ether-

net. At the bottom of the control chain is the fieldbus that links the PLCs to the sensors and actuators (for example, the motors, pumps, and valves in the field) that actually do the work.

Deep well pumps

Also called groundwater pumps, these are typically multistage pumps of either the submersible pump type or the vertical turbine type. Bowl and impellers are often identical, but the submersible pump has a submersible motor, while the vertical turbine has a dry motor above the water.

Development of well

The process of removing the finer material from the aquifer or gravel pack surrounding a new well, which may include drilling mud forced into the formation during well construction. If performed after the well has been in service for some time it is referred to as “re-developing” a well.

Discharge head

The pressure at the discharge flange of a pump.

Distribution uniformity (DU)

A measure of how evenly water soaks into a field during an irrigation. It is usually a percentage between 0 and 100; the higher the number the better. A DU of 100% is theoretically possible but practically impossible to achieve. It is the upper limit of irrigation efficiency if the whole field is sufficiently irrigated.

Drawdown

The difference in elevation between static and dynamic (pumping) water levels in a well, usually following a specified operating time.

Duty point

The duty point of a pump is the flow and head produced when it is pumping at maximum efficiency.

Effective root zone

The depth of soil in which you are actively managing the crop (fertiliser levels, tilth, soil moisture, etc.).

Elevation lift

The term used when a pump transfers water from one elevation level to another elevation level.

Enclosure Class

Enclosure Class is used to classify electrical equipment and states under which condition the equipment may be used (indoor, outdoor, submerged, and so on).

Evapotranspiration (ET)

See “daily crop water use”

Field capacity

The amount of water the soil will hold.

Fertigation

The application of fertiliser and/or soil additions with water from the irrigation system.

Flow meter

Any measuring device used to measure fluid flow rates in a pipe or open channel. The flow meter may measure instantaneous flow rates or total fluid volumes over a period of time.

Freeboard

Distance from the top of the flowing water to the top of the channel banks.

Friction loss

Water pressure lost as a result of contact between moving water and the enclosure that it is moving in (either a pipeline or open channel).

Fuse

An electrical device that protects the electrical system from overload. A fuse is typically fast-reacting, and disconnects the electrical current when a maximum value is exceeded.

Gravel pack

A thin layer of various sizes of gravel placed between the well casing and the well itself. Gravel packs are designed to prevent soil particles from entering the well casing.

Head (meters of head)

A practical measure for pressure as it can be used directly in all metric formulas and calculations.

Horsepower (hp)

Horsepower is a rate of doing work - how far can a mass be moved in a period of time. One hp is equal to 0,746 kW.

Impeller

The impeller is the rotating component of the pump and is contained within the pump bowl (or pump volute). Impellers may be configured as open, closed, or semi-open. They are usually made of bronze, cast iron, plastic, or cast iron coated with porcelain enamel. The impeller transfers energy developed by the pump driver to the water as water flows through the pump bowl. See Chapter 10.

Impeller trim

The specific diameter of the impeller used in a pump. Impellers are cast at the maximum diameter but may be “trimmed” to better match the required operating condition(s).

Irrigation efficiency (IE)

A measure of how much water that is pumped and applied to a field is beneficially used. (Beneficial uses include crop water use and leaching for salt control.) One must know the physical and time boundaries of the measurement for it to be meaningful. The IE for a single irrigation on a field may be different than the average IE for all irrigations on that field for a season. It may be different than the IE for the entire farm for the season. It is usually expressed as a percentage between 0 and 100. An IE of 100% is not theoretically possible due to immediate evaporation of water during irrigation.

Irrigation scheduling

The purpose of irrigation scheduling is to determine the exact amount of water to apply to the field and the exact timing for application. The amount of water applied is determined by using a criterion to determine irrigation need and a strategy to describe how much water to apply in any situation.

Manometer

A portable device using what is known as velocity head (the energy of the moving water) to measure water flow rates in pipelines. These are commonly used during pump efficiency tests due to the ease of installation and removal. However, they are large and require careful handling and are not generally recommended for use by pump owners.

Mixed flow pump

Mixed flow pumps combine the principles of radial and axial flow impeller designs. See page 61.

Multi-stage pump

A pump having more than one impeller/bowl assembly. Commonly used when referring to turbine pumps and submersible pumps. See page 61.

Net positive suction head (NPSH)

A design requirement dependent on the individual pump. The required NPSH must be available at the pump inlet to prevent cavitation.

Net water needed versus gross water applied

Net water is what you need to replace in the field. Gross water is how much you have to pump in order to accomplish this goal.

Operating condition

The combination of flow and pressure (total dynamic head) developed by the pump. A pump can operate at a number of operating conditions defined by its pump performance curve.

Overload relay

A device that protects the equipment, typically an electric motor, from long term overload. An overload relay will allow short term overload without breaking the circuit.

Parallel pumps

Two or more pumps (many times of different sizes for flexibility) discharging into a common pipeline to increase the flow rate at a given pressure in the pipeline.

Programmable Logic Controller (PLC)

A PLC is used for the automation of electromechanical processes, such as control of machinery on factory assembly lines, control of pumps and valves in processing plants and many other similar types of systems. The PLC is designed for flexible multiple inputs and output arrangements, extended temperature ranges, immunity to electrical noise, and resistance to vibration and impact.

Pump

A mechanical device that converts mechanical energy (usually a rotating shaft or reciprocating rod) into hydraulic energy (flowing water for example).

Pump capacity

The flow rate through a pump in cubic meters per hour (m^3/h)

Pump efficiency

The relation between the power produced by the pump (product of flow and head) and the motor horsepower needed to drive the pump. Pump efficiency should be minimum 70%. The pump efficiency can be read from the manufacturer's pump curves.

Pump housing

The pump housing, also called the bowl, is the stationary part of the pump, and often contains guide vanes to convert the rotation energy into pressure.

Pump and motor efficiency

The relation between the power produced by the pump (product of flow and head) and the power absorbed by the motor, in kW. Pump and Motor Efficiency can be measured. See Chapter 12.

Pump performance curve

A set of measurements, usually in graphical form, available from the pump manufacturer showing the relationship between total head, horsepower requirements, and net positive suction head requirements at any given flow rate for a pump.

Pumping lift

The distance from the center line of the discharge pipe at the pump head to the water level in the pumping well.

Pumping water level

The water level in a well after the pump while pumping is in progress. Typically a pump tester will measure this level after 10 to 60 minutes of pumping. This may or may not represent pumping water levels hours or days later.

Radial flow pumps

Radial flow pumps have impeller designs capable of generating a high pressure. See page 61.

Revolutions per minute (RPM)

The rotating speed of the shaft of a pump or the driver (motor).

Sand separator

A device installed on the pump intake pipe in deep-well turbine pumps to remove sand from the water before it can enter the pump. They may also be installed on the pump outlet works and be used to remove sand in water before it enters water distribution systems (municipal, industrial, or irrigation).

SCADA

The term SCADA (Supervisory Control and Data Acquisition) usually refers to centralised systems that monitor and control entire sites, or complexes of systems that can be spread out over large areas (anything from an irrigation system to a country). Most control actions are performed automatically by Dedicated Controllers or by PLCs (Programmable Logic Controller).

Series pumps

Two or more pumps installed so that one pump discharges into the intake of another pump, increasing pressure at a given flow rate. The total head developed by the second pump is added to the total head of the first pump. The most common configuration is a well pump discharging into a booster pump. Note also that a “multi-stage” turbine pump is actually a pump connected in series.

Single stage pump

A single stage pump has only the pump housing or bowl with one impeller.

Soil moisture depletion (SMD)

The net amount of water that you need to replace in the root zone of the crop.

Soil probe

A long piece of ca. 10 mm steel bar, usually tipped by a ball bearing, with a handle. The probe is pressed into wetted soil to judge how deep water has penetrated. It can be used during an irrigation to indicate when enough water has soaked into the ground. It can also be used to judge the uniformity of an irrigation. If 2-3 days after an irrigation the probe can be pushed into the soil to a depth of ca. 1.2 m at the top of a furrow, and only to 0.6 feet at the bottom of the same furrow, this is an indication of poor distribution uniformity.

Stage

One impeller/bowl assembly of a multi-stage pump. Pumps can be termed as “single-stage” or “multi-stage” pumps.

Static water level

The depth of the water level in a well when unaffected by the pumping of that well.

Suction lift (suction head)

Distance from the water surface to the pump intake when the pump is located above the water surface.

Suction water level

The water level from where the pump must pump the water.

Submersible pump

A type of deep well pump that utilises a waterproof electric motor connected directly to the pump, both installed in the well below the pumping water level.

System curve

The system curve of a pumping system is a term for the friction in the system. The friction comes from pipes, valves, elbows, tee's, and the like, and is often constant. Clogging of the system, or if a valve's setting is changed are examples of things that will change the system curve. By definition the system curve always goes through the duty point of the pump.

Tailwater

Tailwater refers to waters located immediately downstream from a hydraulic structure, such as a dam, bridge or culvert.

Time-of-use rates (TOU)

Electric power rate schedules whereby lower costs are offered for power used in the “off-peak” (and sometimes during the “shoulder” or “mid-peak”) period and higher rates are charged for power used during “on-peak” periods. The term “onpeak” refers to times when power use is the highest for a utility. Conversely, offpeak refers to that time when power use is lowest.

Totaliser

A type of flow meter, or a part of a flow meter, that provides a measure of total water volume flowing past a point over time.

Turbine pump

This pump operates on the principle of centrifugal action. As water enters the impeller it is flung outward, gaining energy, through the rotation of the impeller. Many times, multiple pump assemblies (pump bowl and impeller) are stacked on top of each other and the water is directed by the pump bowl upwards to the next impeller/bowl assembly.

Uniformity

Also called Distribution Uniformity. Uniformity is in percent, and the number indicates how even a given amount of water is distributed over a given area. The higher the number, the better is the uniformity.

Variable frequency (speed) drive (VFD)

A solid-state electrical device used to change the frequency of AC electric energy supplied to an electric motor. Varying the frequency of the AC current will vary the speed of the motor, allowing the electric motor to be throttled like an internal combustion engine. VFDs are used in situations requiring many different operating conditions on a regular basis.

Vertical turbine pump (VTP)

A turbine pump installed inside a well casing below the pumping water level in the well. The motor is not installed in the water.

Viscosity

The viscosity of a fluid says something about how thick or thin it is, and how easy it will flow. A thick fluid, like syrup, has a high viscosity, while water has a low viscosity.

Water hammer

Water hammer can occur when water is flowing in a pipe and a valve is closed too quickly, causing possible damage to the pipes. See page 76.

Well casing

Pipe (usually some type of metal but may also be plastic) used as the lining for a well. A layer of rock (termed the “gravel pack”) is usually placed between the well casing and the aquifer to help prevent soil particles from entering the well. The casing will have small openings (called perforations or slots) at levels where water-bearing soil formations are thought to be.

Well efficiency

The drawdown outside the well casing divided by the drawdown inside the well (the higher the number the better).

be think innovate



The name Grundfos, the Grundfos logo, and the payoff Be–Think–Innovate are registered trademarks owned by Grundfos Holding A/S or Grundfos A/S, Denmark. All rights reserved worldwide. 98488065/0613/WATER UTILITY/10557-D&I

GRUNDFOS 

GRUNDFOS Holding A/S
Poul Due Jensens Vej 7
DK-8850 Bjerringbro
Tel: +45 87 50 14 00
www.grundfos.com