

PowerStrike Series

Remote Power Supplies/Battery Chargers
Instruction Manual

Fire Alarm & Emergency Communication System Limitations

While a life safety system may lower insurance rates, it is not a substitute for life and property insurance!

An automatic fire alarm system—typically made up of smoke detectors, heat detectors, manual pull stations, audible warning devices, and a fire alarm control panel (FACP) with remote notification capability—can provide early warning of a developing fire. Such a system, however, does not assure protection against property damage or loss of life resulting from a fire.

An emergency communication system—typically made up of an automatic fire alarm system (as described above) and a life safety communication system that may include an autonomous control unit (ACU), local operating console (LOC), voice communication, and other various interoperable communication methods—can broadcast a mass notification message. Such a system, however, does not assure protection against property damage or loss of life resulting from a fire or life safety event.

The Manufacturer recommends that smoke and/or heat detectors be located throughout a protected premises following the recommendations of the current edition of the National Fire Protection Association Standard 72 (NFPA 72), manufacturer's recommendations, State and local codes, and the recommendations contained in the Guide for Proper Use of System Smoke Detectors, which is made available at no charge to all installing dealers. This document can be found at <http://www.systemsensor.com/appguides/>. A study by the Federal Emergency Management Agency (an agency of the United States government) indicated that smoke detectors may not go off in as many as 35% of all fires. While fire alarm systems are designed to provide early warning against fire, they do not guarantee warning or protection against fire. A fire alarm system may not provide timely or adequate warning, or simply may not function, for a variety of reasons:

Smoke detectors may not sense fire where smoke cannot reach the detectors such as in chimneys, in or behind walls, on roofs, or on the other side of closed doors. Smoke detectors also may not sense a fire on another level or floor of a building. A second-floor detector, for example, may not sense a first-floor or basement fire.

Particles of combustion or "smoke" from a developing fire may not reach the sensing chambers of smoke detectors because:

- Barriers such as closed or partially closed doors, walls, chimneys, even wet or humid areas may inhibit particle or smoke flow.
- Smoke particles may become "cold," stratify, and not reach the ceiling or upper walls where detectors are located.
- Smoke particles may be blown away from detectors by air outlets, such as air conditioning vents.
- Smoke particles may be drawn into air returns before reaching the detector.

The amount of "smoke" present may be insufficient to alarm smoke detectors. Smoke detectors are designed to alarm at various levels of smoke density. If such density levels are not created by a developing fire at the location of detectors, the detectors will not go into alarm.

Smoke detectors, even when working properly, have sensing limitations. Detectors that have photoelectric sensing chambers tend to detect smoldering fires better than flaming fires, which have little visible smoke. Detectors that have ionizing-type sensing chambers tend to detect fast-flaming fires better than smoldering fires. Because fires develop in different ways and are often unpredictable in their growth, neither type of detector is necessarily best and a given type of detector may not provide adequate warning of a fire.

Smoke detectors cannot be expected to provide adequate warning of fires caused by arson, children playing with matches (especially in bedrooms), smoking in bed, and violent explosions (caused by escaping gas, improper storage of flammable materials, etc.).

Heat detectors do not sense particles of combustion and alarm only when heat on their sensors increases at a predetermined rate or reaches a predetermined level. Rate-of-rise heat detectors may be subject to reduced sensitivity over time. For this reason, the rate-of-rise feature of each detector should be tested at least once per year by a qualified fire protection specialist. Heat detectors are designed to protect property, not life.

IMPORTANT! Smoke detectors must be installed in the same room as the control panel and in rooms used by the system for the connection of alarm transmission wiring, communications, signaling, and/or power. If detectors are not so located, a developing fire may damage the alarm system, compromising its ability to report a fire.

Audible warning devices such as bells, horns, strobes, speakers and displays may not alert people if these devices are located on the other side of closed or partly open doors or are located on another floor of a building. Any warning device may fail to alert people with a disability or those who have recently consumed drugs, alcohol, or medication. Please note that:

- An emergency communication system may take priority over a fire alarm system in the event of a life safety emergency.
- Voice messaging systems must be designed to meet intelligibility requirements as defined by NFPA, local codes, and Authorities Having Jurisdiction (AHJ).
- Language and instructional requirements must be clearly disseminated on any local displays.
- Strobes can, under certain circumstances, cause seizures in people with conditions such as epilepsy.
- Studies have shown that certain people, even when they hear a fire alarm signal, do not respond to or comprehend the meaning of the signal. Audible devices, such as horns and bells, can have different tonal patterns and frequencies. It is the property owner's responsibility to conduct fire drills and other training exercises to make people aware of fire alarm signals and instruct them on the proper reaction to alarm signals.
- In rare instances, the sounding of a warning device can cause temporary or permanent hearing loss.

A life safety system will not operate without any electrical power. If AC power fails, the system will operate from standby batteries only for a specified time and only if the batteries have been properly maintained and replaced regularly.

Equipment used in the system may not be technically compatible with the control panel. It is essential to use only equipment listed for service with your control panel.

Alarm Signaling Communications:

- **IP connections** rely on available bandwidth, which could be limited if the network is shared by multiple users or if ISP policies impose restrictions on the amount of data transmitted. Service packages must be carefully chosen to ensure that alarm signals will always have available bandwidth. Outages by the ISP for maintenance and upgrades may also inhibit alarm signals. For added protection, a backup cellular connection is recommended.
- **Cellular connections** rely on a strong signal. Signal strength can be adversely affected by the network coverage of the cellular carrier, objects and structural barriers at the installation location. Utilize a cellular carrier that has reliable network coverage where the alarm system is installed. For added protection, utilize an external antenna to boost the signal.
- **Telephone lines** needed to transmit alarm signals from a premise to a central monitoring station may be out of service or temporarily disabled. For added protection against telephone line failure, backup alarm signaling connections are recommended.

The most common cause of life safety system malfunction is inadequate maintenance. To keep the entire life safety system in excellent working order, ongoing maintenance is required per the manufacturer's recommendations, and UL and NFPA standards. At a minimum, the requirements of NFPA 72 shall be followed. Environments with large amounts of dust, dirt, or high air velocity require more frequent maintenance. A maintenance agreement should be arranged through the local manufacturer's representative. Maintenance should be scheduled as required by National and/or local fire codes and should be performed by authorized professional life safety system installers only. Adequate written records of all inspections should be kept.

Limit-F-2020

Installation Precautions

Adherence to the following will aid in problem-free installation with long-term reliability:

WARNING - Several different sources of power can be connected to the fire alarm control panel. Disconnect all sources of power before servicing. Control unit and associated equipment may be damaged by removing and/or inserting cards, modules, or inter-connecting cables while the unit is energized. Do not attempt to install, service, or operate this unit until manuals are read and understood.

CAUTION - System Re-acceptance Test after Software Changes:

To ensure proper system operation, this product must be tested in accordance with NFPA 72 after any programming operation or change in site-specific software. Re-acceptance testing is required after any change, addition or deletion of system components, or after any modification, repair or adjustment to system hardware or wiring. All components, circuits, system operations, or software functions known to be affected by a change must be 100% tested. In addition, to ensure that other operations are not inadvertently affected, at least 10% of initiating devices that are not directly affected by the change, up to a maximum of 50 devices, must also be tested and proper system operation verified.

This system meets NFPA requirements for operation at 0-49° C/32-120° F and at a relative humidity 93% ± 2% RH (non-condensing) at 32°C ± 2°C (90°F ± 3°F). However, the useful life of the system's standby batteries and the electronic components may be adversely affected by extreme temperature ranges and humidity. Therefore, it is recommended that this system and its peripherals be installed in an environment with a normal room temperature of 15-27° C/60-80° F.

Verify that wire sizes are adequate for all initiating and indicating device loops. Most devices cannot tolerate more than a 10% I.R. drop from the specified device voltage.

Like all solid state electronic devices, this system may operate erratically or can be damaged when subjected to lightning induced transients. Although no system is completely immune from lightning transients and interference, proper grounding will reduce susceptibility. Overhead or outside aerial wiring is not recommended, due to an increased susceptibility to nearby lightning strikes. Consult with the Technical Services Department if any problems are anticipated or encountered.

Disconnect AC power and batteries prior to removing or inserting circuit boards. Failure to do so can damage circuits.

Remove all electronic assemblies prior to any drilling, filing, reaming, or punching of the enclosure. When possible, make all cable entries from the sides or rear. Before making modifications, verify that they will not interfere with battery, transformer, or printed circuit board location.

Do not tighten screw terminals more than 9 in-lbs. Over-tightening may damage threads, resulting in reduced terminal contact pressure and difficulty with screw terminal removal.

This system contains static-sensitive components. Always ground yourself with a proper wrist strap before handling any circuits so that static charges are removed from the body. Use static suppressive packaging to protect electronic assemblies removed from the unit.

Units with a touchscreen display should be cleaned with a dry, clean, lint free/microfiber cloth. If additional cleaning is required, apply a small amount of Isopropyl alcohol to the cloth and wipe clean. Do not use detergents, solvents, or water for cleaning. Do not spray liquid directly onto the display.

Follow the instructions in the installation, operating, and programming manuals. These instructions must be followed to avoid damage to the control panel and associated equipment. FACP operation and reliability depend upon proper installation.

Precau-D2-11-2017

FCC Warning

WARNING: This equipment generates, uses, and can radiate radio frequency energy and if not installed and used in accordance with the instruction manual may cause interference to radio communications. It has been tested and found to comply with the limits for class A computing devices pursuant to Subpart B of Part 15 of FCC Rules, which is designed to provide reasonable protection against such interference when devices are operated in a commercial environment. Operation of this equipment in a residential area is likely to cause interference, in which case the user will be required to correct the interference at his or her own expense.

Canadian Requirements

This digital apparatus does not exceed the Class A limits for radiation noise emissions from digital apparatus set out in the Radio Interference Regulations of the Canadian Department of Communications.

Le présent appareil numérique n'émet pas de bruits radioélectriques dépassant les limites applicables aux appareils numériques de la classe A prescrites dans le Règlement sur le brouillage radioélectrique édicté par le ministère des Communications du Canada.

Phoenix G2® is a registered trademark of Honeywell International, Inc. HARSH™, NIS™, and NOTI•FIRE•NET™ are all trademarks; and Acclimate®, ECLIPSE®, Filtrex®, FlashScan®, Honeywell®, NOTIFIER®, ONYX®, ONYXWorks®, Pinnacle®, VeriFire®, and VIEW® are all registered trademarks of Honeywell International Inc. Microsoft® and Windows® are registered trademarks of the Microsoft Corporation. Chrome™ and Google™ are trademarks of Google Inc. Firefox® is a registered trademark of The Mozilla Foundation.

©2023 by Honeywell International Inc. All rights reserved. Unauthorized use of this document is strictly prohibited.

Software Downloads

In order to supply the latest features and functionality in fire alarm and life safety technology to our customers, we make frequent upgrades to the embedded software in our products. To ensure that you are installing and programming the latest features, we strongly recommend that you download the most current version of software for each product prior to commissioning any system. Contact Technical Support with any questions about software and the appropriate version for a specific application.

Documentation Feedback

Your feedback helps us keep our documentation up-to-date and accurate. If you have any comments or suggestions about our online Help or printed manuals, you can email us.

Please include the following information:

- Product name and version number (if applicable)
- Printed manual or online Help
- Topic Title (for online Help)
- Page number (for printed manual)
- Brief description of content you think should be improved or corrected
- Your suggestion for how to correct/improve documentation

Send email messages to:

FireSystems.TechPubs@honeywell.com

Please note this email address is for documentation feedback only. If you have any technical issues, please contact Technical Services.



This symbol (shown left) on the product(s) and / or accompanying documents means that used electrical and electronic products should not be mixed with general household waste. For proper treatment, recovery and recycling, contact your local authorities or dealer and ask for the correct method of disposal.

Electrical and electronic equipment contains materials, parts and substances, which can be dangerous to the environment and harmful to human health if the waste of electrical and electronic equipment (WEEE) is not disposed of correctly.

Table of Contents

Section 1: System Overview	8
1.1: General	8
1.2: Features	8
1.3: Specifications	9
1.4: Open/Short/Ground Fault Trip Values in Standby	9
1.5: Switch SW1 - Ground Fault Detection	10
1.6: Model Numbers	11
1.7: Applications	11
1.8: Start-up Procedure	11
Section 2: Installation	12
2.1: Backbox Mounting	12
2.2: NAC Circuit Wiring	13
2.2.1: Class B	13
2.2.2: ZNAC-PS Class A Option Module	13
2.3: Addressable Module Mounting	14
2.4: NEC Power-limited (Class 2) Wiring Requirements	16
2.5: FACP with the Power Supply in Slave Configuration	17
2.6: Power Supply in Master Configuration Connected to FACP	17
2.7: Connecting to an External Charger	18
2.7.1: CHG-120	18
2.7.2: CHG-75	18
2.8: Connecting Multiple Power Supplies	19
2.8.1: Cascading Multiple Units	19
2.8.2: Daisy-chaining Multiple Units	20
2.9: Canadian Applications	20
2.10: Ground Fault Detection	20
Section 3: Programming Options	23
3.1: S1 Global Options DIP Switch	24
3.1.1: Global Programmable Features Description	24
Input Debounce/Dejitter/Delay	24
Command Input #1	25
Charger Enable/Disable	25
AC Loss Door Holder Dropout Timer	25
AC Fail Indication Delay	26
Operating Modes	26
3.2: Output Circuit Control DIP Switch Settings	27
3.2.1: Output Circuit Programmable Features Description	28
Command Inputs/NAC Circuit Activation	28
Unused Outputs	28
Remote Supply with Resettable and Non-resettable Power	28
Door Holder	29
Synchronizing NACs - Master/Slave Configurations	29
Master Configuration - Selective Silence	29
Class A Wiring	30
Section 4: LED Indicators	31
Section 5: Trouble Supervision	33
5.1: Trouble Supervision Using Input Circuits	33
5.2: General Trouble Relay	34
5.3: AC Trouble Relay	35
5.4: Ground Fault Relay	35
Section 6: Power Supply Requirements	36
6.1: Overview	36
6.2: Calculating the AC Branch Circuit	36
6.3: Calculating the System Current Draw	36
6.3.1: Overview	36
6.3.2: How to Calculate System Current Draw	37
6.4: Selecting and Locating Batteries	37
6.4.1: NFPA Battery Requirements	37

6.4.2: Maximum Battery Standby Load.....	38
Section 7: Testing and Maintenance	39
7.1: Periodic Testing and Service.....	39
7.2: Battery Checks and Maintenance	39
Appendix A: Wire Requirements.....	40
Appendix B: Application Examples	41
B.1: Controlling NACs For Selective Silence Operation Using a Control Module	41
B.2: Controlling NACs For Sync Follower Operation Using a Control Module (Default Mode Configuration Only).....	42
B.3: Controlling NACs, Aux Power, or Door Holders Using a Control Module	43
B.4: Controlling NACs, Aux Power, and Door Holders with NAC Sync	44
B.5: Controlling all Three Inputs with One Control Module.....	45
B.6: AC Trouble Reporting with a Conventional FACP.....	46
B.7: Canadian Two-Stage	47
B.8: Canada Two-Stage Application Using a Multi-Control Module.....	48
Index	49

It is imperative that the installer understand the requirements of the Authority Having Jurisdiction (AHJ) and be familiar with the standards set forth by the following regulatory agencies:

- Underwriters Laboratories Standards
- NFPA 72 National Fire Alarm Code

Before proceeding, the installer should be familiar with the following documents.



NFPA Standards

NFPA 72 National Fire Alarm Code
NFPA 70 National Electrical Code



Underwriters Laboratories Documents:

UL 464 Audible Signaling Appliances
UL 864 Standard for Control Units for Fire Protective Signaling Systems
UL 1638 Visual Signaling Appliances
UL 1971 Signaling Devices for Hearing Impaired
UL 2572 Standard for Mass Notification Systems



CAN/ULC - S524 Standard for Installation of Fire Alarm Systems
CAN/ULC - S527 Standard for Control Units for Fire Alarm Systems

Other:

NEC Article 250 Grounding
NEC Article 300 Wiring Methods
NEC Article 760 Fire Protective Signaling Systems
Applicable Local and State Building Codes
Requirements of the Local Authority Having Jurisdiction (LAHJ)
Canadian Electrical Code, Part 1

Other Documents:

Device Compatibility Document branded for the FACP

Document #15378 (NOTIFIER),
#15384 (Fire•Lite),
#54399 (HPP),
#52612 or #LS10167-004SK-E (Silent Knight),
#LS10167-003FH-E (Farenhyt),
#52195 or #9000-0427-L8 (Gamewell-FCI)

SLC Wiring Manual branded for the FACP

Document #51253 or #LS10055-151NF-E (NOTIFIER),
#51309 (Fire•Lite),
#51932 (HPP),
#LS10179-000SK-E (Silent Knight)
#LS10179-000FH-E (Farenhyt)
#9000-0427-L8 (Gamewell-FCI)

CHG-75 Manual

Document #51315

CHG-120 Manual

Document #50641

This product has been certified to comply with the requirements in the Standard for Control Units and Accessories for Fire Alarm Systems, UL 864, 10th Edition. Operation of this product with products not tested for UL 864, 9th/10th Edition has not been evaluated. Such operation requires the approval of the local Authority Having Jurisdiction (AHJ).

Section 1: System Overview

The PowerStrike Series features a 6 amp and a 10 amp remote power supply with battery charger. Both models provide ADA compatible strobe synchronization and a filtered 24 VDC output that can be configured to drive five (6 amp model) or seven (10 amp model) Class B NACs (Notification Appliance Circuits). NAC circuits can be configured for Class A wiring with the optional ZNAC-PS Class A converter module. NAC output circuits may be configured as 24 VDC resettable or non-resettable power outputs, or Class D door holder outputs. The input circuits, which control the power supply operation, are triggered by the reverse polarity of a NAC or by a 12 VDC or 24 VDC power source. The power supplies are compatible with 12 VDC and 24 VDC control panels.

A domestic black cabinet offering is available for the 6 amp and 10 amp units.

An export 6 amp and 10 amp unit are available for connection to 240 VAC. Unless otherwise specified, the information in this manual applies to both the 120 VAC and the 240 VAC models.

1.1 General

These power supplies can be used as remotely mounted power supplies and battery chargers to power non-coded or coded NACs. The Main FACP (Fire Alarm Control Panel) NAC(s) is connected to the remote power supply input circuit(s). When the command input circuit activates due to reverse polarity of the NAC from the FACP, the power supply will activate its Notification Appliance Circuits.

During the inactive or non-alarm state, the power supply supervises its NAC field wiring for short and open conditions. In Default Mode, AC fail, battery, charger and ground fault troubles will also be monitored by the power supply and will activate the AC Fail, General Trouble, and Ground Fault relay, respectively. In Retrofit Mode, AC fail, battery, charger, and ground fault troubles will activate the General Trouble relay and either the Input#1 (If Input#1 is configured as Normal) or Input#2 (If Input#1 is configured as Sync Input). The retrofit mode also allows to further customize the AC fail and ground fault trouble indication, to be reported only at the AC fail and Ground fault relay (for Canadian applications) using S1 Global DIP Switch 8. In both default and retrofit modes, if a NAC fault is detected, the input end-of-line relay will open to indicate the fault to the main panel. However, in alarm state all input end-of-line relays are closed to allow input signal daisy-chaining. If an alarm condition occurs and the NAC is activated, the supervision is disabled and the Notification Appliance Circuit is no longer supervised (except for power-limited conditions).

1.2 Features

- Operates in Default Mode (UL 864 10th Edition compliant) or Retrofit Mode (for use in existing, legacy installations)
- Self-contained in a lockable cabinet
- 24 VDC remote power supply
- Outputs are completely power-limited (Class 2)
- Two (6 amp power supply) or three (10 amp power supply) optically-isolated input/command circuits, compatible with 12 VDC and 24 VDC control panel NACs
- Five (6 amp power supply) or seven (10 amp power supply) output circuits:
 - Fully filtered power
 - Five or seven 24 VDC Class B NACs
 - Optional ZNAC-PS Class A converter module for conversion to Class A NACs
 - Alternatively, all output circuits may be configured as 24 VDC special application power outputs or Class D door holder power outputs
 - Output circuits may be configured as resettable or non-resettable
- Individual NAC Power (red) and Trouble (yellow) LEDs for each output
- Maximum current available:
 - 6 amp power supply: TB8-TB9 – 1A Regulated, 3A special applications; TB10-TB12 – 0.3A Regulated, 3A special applications
 - 10 amp power supply: TB8-TB11 – 1.5A Regulated, 3A special applications; TB12-TB14 – 0.3A Regulated, 3A special applications
- Maximum total current available (alarm and standby):
 - 6.0 amps for 6 amp power supply alarm; 3.0 amps standby
 - 10.0 amps for 10 amp power supply alarm; 3.0 amps standby
- Integral supervised battery charger for lead acid batteries only
- Capable of charging 7.0 AH - 33.0 AH (Amp Hour) batteries (cabinet fits 7 or 18 AH batteries)
- Fully supervised power supply, battery and NACs
- Selectable Strobe Synchronization for NACs (System Sensor, Gentex, Wheelock, and Amseco)
- Coded signal synchronization
- Removable terminal blocks for field wiring capable of accepting 12 - 18 AWG wire
- Selectable Ground Fault detection by switch SW1
- LED trouble diagnostics and history
- Power supply trouble, AC Loss, and Ground Fault Form-C relay contacts (fail-safe)
- Optional delay of AC loss reporting for 0, 2, 12, or 30 hours
- Mounting location for optional addressable module
- Up to four power supplies can be cascaded

1.3 Specifications

Refer to Figure 1.1 on page 10 for terminal locations.



NOTE: The 6 amp power supply uses the same PCB layout as the 10 amp power supply, however some terminals will be depopulated, leaving the 6 amp power supply with five output circuits and two input circuits.

Primary AC Power - TB4

- 6 amp power supply: 120 VAC, 50/60 Hz, 5.0 amps maximum
- 10 amp power supply: 120 VAC, 50/60 Hz, 6.2 amps maximum
- 6 amp power supply, Export variant: 240 VAC, 50/60 Hz, 2.7 amps maximum
- 10 amp power supply, Export variant: 240 VAC, 50/60 Hz, 3.5 amps maximum
- Wire size: #12-14 AWG wire with 600V insulation

Command Input Circuits - TB5, TB6, TB7

- Trigger Input Voltage: 9 - 32 VDC
- Input Current Draw in Alarm Polarity: 14.0 mA maximum per input

Output Circuits - TB8-TB14

- Supervised and power-limited
- Voltage Rating: 24 VDC filtered, 19.72 – 26.40 VDC range;
Special Application Selectable Strobe Synchronization for NACs: 19.2 – 26.4 VDC measured range
- Current:
 - 6 amp power supply: TB8-TB9 – 1A Regulated, 3A special applications; TB10-TB12 – 0.3A Regulated, 3A special applications (Regulated power is for industrial horn, strobes, and chimes not included in the Device Compatibility Document. Special application power is for NAC devices included in Device Compatibility Document, aux power, and door holders.)
 - 6 amp power supply: TB8-TB11 – 1.5A Regulated, 3A special applications; TB12-TB14 – 0.3A Regulated, 3A special applications (Regulated power is for industrial horn, strobes, and chimes not included in the Device Compatibility Document. Special application power is for NAC devices included in Device Compatibility Document, aux power, and door holders.)
 - Maximum total alarm current for all output:
 - 6 amp power supply - 6.0 amps
 - 6 amp power supply - 10.0 amps
- Output Circuit Types:
 - Class B NACs (require 2k Ω - 27k Ω End-of-Line Resistors) and/or Class A NACs using the optional ZNAC-PS Class A converter module. Use Listed ELRs supplied by the FACP or compatible equipment manufacturer.
 - Resettable or non-resettable outputs for 24 VDC power outputs or Class D door holder (max ripple voltage: 780mV_{RMS})
- Refer to the *Device Compatibility Document* for the brand of FACP for listed compatible devices.
- For wiring requirements, refer to “Wire Requirements” on page 40.

Trouble, AC Loss, and Ground Fault Relay Contact Rating - TB1-TB3

- Fail-safe Form-C relay (normally energized, transfers with loss of power) for AC Loss and Trouble
- 4.0 amps @ 30 VDC resistive

Secondary Power (battery) Charging Circuit - TB15

- Supervised, non-power-limited
- Supports lead acid type batteries only
- Float Charge Voltage: 27.6 VDC
- Maximum Peak Charge Current: 2.47A
- Maximum Nominal Charge Current: 1.5 A
- Maximum Battery Capacity: 33.0 AH (with onboard battery charger)
- Minimum Battery Capacity: 7.0 AH



NOTE: The power supply only supports 7AH or 18AH batteries in the cabinet. Other battery capacities up to 33AH will not fit in the cabinet due to physical dimensions and require a separate battery cabinet.

1.4 Open/Short/Ground Fault Trip Values in Standby

Table 1.1 lists the earth fault resistance detection in standby for each applicable terminal on the FACP.

Output Circuit	Terminal	Trip Resistance (in ohms)
NAC 1-5/7	+	9.9K or lower
NAC 1-5/7	-	9.2K or lower
ZNAC-PS 1-5/7	+	9.9K or lower
ZNAC-PS 1-5/7	-	9K or lower

Table 1.1 Earth Fault Trip Values

Value of the resistance in between any circuit terminal to Earth, which will cause the Ground Fault detection, depends on the ELR chosen for inputs and output circuits. This resistance will vary from 9.9K down to 0 Ohm.

Table 1.2 lists the open/short trip values and restoral values in standby for the NAC circuits on the FACP.

Circuit	Fault	Trip Resistance (in ohms)	Restore Value
NAC 1-5/7	Short	1.6K or lower	1.7K or higher
NAC 1-5/7	Open	55K or higher	33K or lower
ZNAC-PS 1-5/7	Short	1.6K or lower	1.7K or higher
ZNAC-PS 1-5/7	Open	45K or higher	21K or lower

Table 1.2 NAC Open/Short Trip Values

1.5 Switch SW1 - Ground Fault Detection

The Ground Fault Detection circuit monitors for ground faults. Switch SW1 is located on the lower left section of the power supply circuit board. Sliding SW1 to the left will disable ground fault detection by the power supply. This should only be done if ground faults are being monitored by an FACP connected to the power supply or in a cascading application as shown in Section 2.8.1 on page 19.

Note: The 6 amp power supply uses the same PCB layout, however some terminals will be depopulated, leaving the 6 amp power supply with five output circuits and two inputs circuits.

TB4 AC Power
Supervised,
Non-power-limited
AC2 (Neutral)
Earth
AC1 (Hot)

**Power-limited
(Class 2),
Supervised,
Special
Application or
Regulated
Outputs**

**Form-C Relays
Non-supervised**

- NAC/Out 7 -
- NAC/Out 7 +
- NAC/Out 6 -
- NAC/Out 6 +
- NAC/Out 5 -
- NAC/Out 5 +
- NAC/Out 4 -
- NAC/Out 4 +
- NAC/Out 3 -
- NAC/Out 3 +
- NAC/Out 2 -
- NAC/Out 2 +
- NAC/Out 1 -
- NAC/Out 1 +

Output Status LEDs
Trouble (yellow)
Power (red)

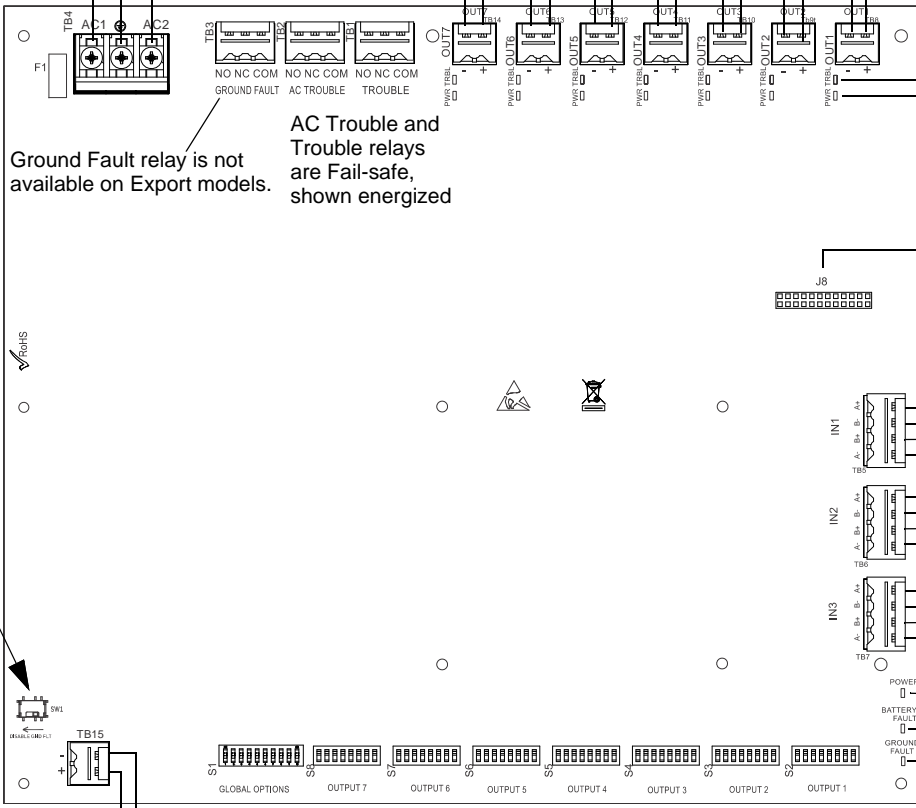

Ground Fault relay is not available on Export models.

AC Trouble and Trouble relays are Fail-safe, shown energized

SW1 Ground Fault Detection
(slide left to disable)
(slide right to enable)

TB15 Supervised + Battery - Battery 24 VDC Non-power-limited

S1 Programming DIP Switch for global options

S2-S8 Programming DIP Switches
Activate output DIP switch changes by setting S1 positions 9 and 10 appropriately. Refer to page 27 for DIP Switch programming settings. Each output circuit has its own dedicated programming DIP switch

Figure 1.1 10 Amp Power Supply Board Layout

1.6 Model Numbers

The PowerStrike Series consists of the following current and legacy model numbers.

Ratings	Current Models	Legacy Models		
120 VAC, 50/60 Hz, 5.0 amps max.	<ul style="list-style-type: none"> • HPF-PS6 (red) • HPF-PS6B (black) 	<ul style="list-style-type: none"> • PSE-6 (black) • PSE-6C (black) • PSE-6R (red) 	<ul style="list-style-type: none"> • FL-PS6 (red) • FL-PS6C (red) 	<ul style="list-style-type: none"> • SK-PS6 (red)
120 VAC, 50/60 Hz, 6.2 amps max.	<ul style="list-style-type: none"> • HPF-PS10 (red) • HPF-PS10B (black) 	<ul style="list-style-type: none"> • PSE-10 (black) • PSE-10C (black) • PSE-10R (red) 	<ul style="list-style-type: none"> • FL-PS10 (red) • FL-PS10C (red) 	<ul style="list-style-type: none"> • SK-PS10 (red)
240 VAC, 50/60 Hz, 2.7 amps max.	<ul style="list-style-type: none"> • HPF-PS6E (red) 	<ul style="list-style-type: none"> • PSE-6E (black) 		
240 VAC, 50/60 Hz, 3.5 amps max.	<ul style="list-style-type: none"> • HPF-PS10E (red) 	<ul style="list-style-type: none"> • PSE-10E (black) 		

Table 1.3 Model Numbers

1.7 Applications

The power supply may be used in a number of different applications. It may be used as a remotely-mounted power supply and battery charger where it can provide up to seven coded or non-coded, synchronized or non-synchronized NACs (Notification Appliance Circuits). Alternatively, any output can be used as a door holder circuit which will provide a steady 24 VDC output until an alarm condition or AC fail condition causes it to drop to 0 VDC following a selectable delay. See the DIP switch settings for S1 global options on page 24. All outputs can also provide power.

One possible application for the remote power supply utilizes the NAC repeater feature. In this application, one or two NACs are connected from the main FACP to the remote power supply command input circuits. When the command input circuits are activated by the reverse polarity of the NACs, the power supply will activate its corresponding output circuits as programmed by its DIP switch configuration (refer to Table 3.9 on page 27).

During the inactive state, the remote power supply supervises its NAC field wiring for short and open conditions. If a fault is detected, the power supply will enter a trouble condition and illuminate the NAC Trouble LED. When the NACs are activated, the supervision is disabled and the circuits are no longer supervised (except for power-limited conditions). Supervision of other power supply faults such as low battery, battery charger trouble, ground fault and AC loss will continue and may be monitored via their respective trouble relay.

If an application requires that all outputs activate at the same time, only one NAC is required from the FACP. For this application, the NAC is connected to command input circuit #1 and the DIP switch is set for this operation.

1.8 Start-up Procedure

1. Configure the power supply switch as described in “Switch SW1 - Ground Fault Detection” on page 10.
2. Install the power supply as described in “Installation” on page 12.
3. Program the power supply as described in “Programming Options” on page 23.
4. Wire the power supply circuits, referring to the options described in “Trouble Supervision” on page 33 and the application examples in “Application Examples” on page 41.
5. Connect primary power source wiring while observing the following:
 - Ensure the AC mains circuit breaker is **off** before making any wiring connections between the mains and the power supply.
 - Make certain primary power source is:
120 VAC, 50/60 Hz, 5.0 (6 amp model) 6.2 amps (10 amp model) or
240 VAC, 50/60 Hz, 2.7 (6 amp model) 3.5 (10 amp model)
 - Run a pair of wires (with ground conductor) from the protected premises main breaker box to TB4 of the power supply main circuit board.
 - Use #12-14 AWG gauge wire with 600V insulation.
6. Apply power to the power supply using the following procedure:
 - Apply AC power by turning on the AC mains circuit breaker connected to the power supply.
 - Connect a properly charged battery to connector TB15 on the power supply main circuit board.
7. Clear trouble history using global DIP switch S1 positions 9 and 10. See DIP switch settings in Table 3.8 on page 27.

Section 2: Installation

Carefully unpack the system and check for shipping damage. Select a location for the cabinet that is in a clean, dry, vibration-free area where extreme temperatures are not encountered. The area should be readily accessible with sufficient room to easily install and maintain the power supply. With the hinge mounting on the left, determine the number of conductors required for the devices to be installed and determine the appropriate knockouts. All wiring must be in accordance with the National and/or Local codes for fire alarm systems and power supplies.

2.1 Backbox Mounting



CAUTION: STATIC SENSITIVE COMPONENTS

THE CIRCUIT BOARD CONTAINS STATIC-SENSITIVE COMPONENTS. ALWAYS GROUND YOURSELF WITH A PROPER WRIST STRAP BEFORE HANDLING ANY BOARDS SO THAT STATIC CHARGES ARE REMOVED FROM THE BODY. USE STATIC SUPPRESSIVE PACKAGING TO PROTECT ELECTRONIC ASSEMBLIES.

1. Mark and pre-drill holes for the top two keyhole mounting bolts.
2. Install two upper fasteners in the wall with the screw heads protruding approximately 1/4".
3. Using the upper keyholes, mount the backbox over the two screws.
4. Mark the lower two holes, remove the backbox from the wall and drill the mounting holes.
5. Mount the backbox, install the remaining fasteners and tighten all screws..

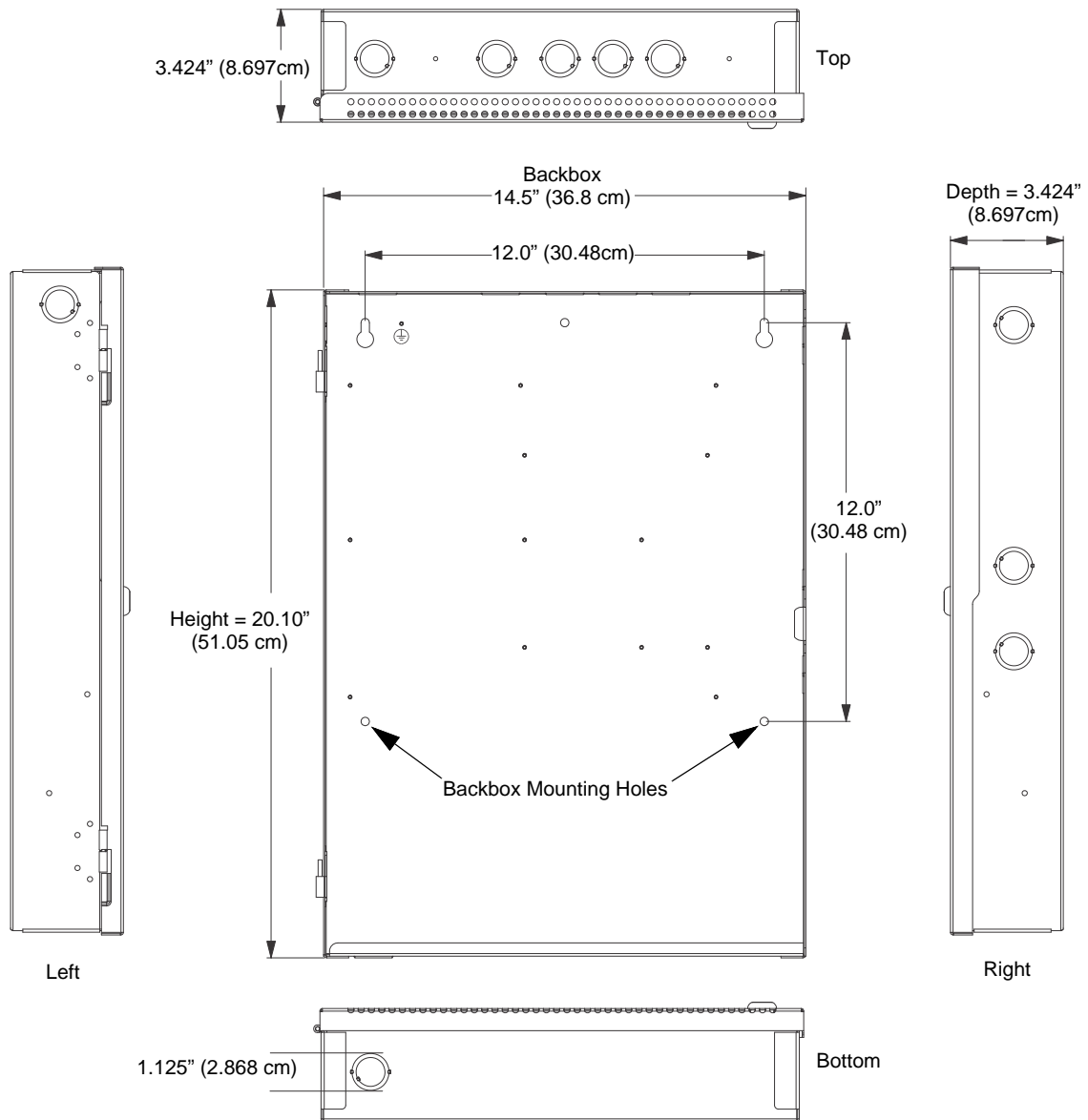

Figure 2.1 Backbox Mounting Dimensions

2.2 NAC Circuit Wiring

2.2.1 Class B

The standard configuration for NACs is Class B as shown below. Use Listed ELRs supplied by the FACP or compatible equipment manufacturer.

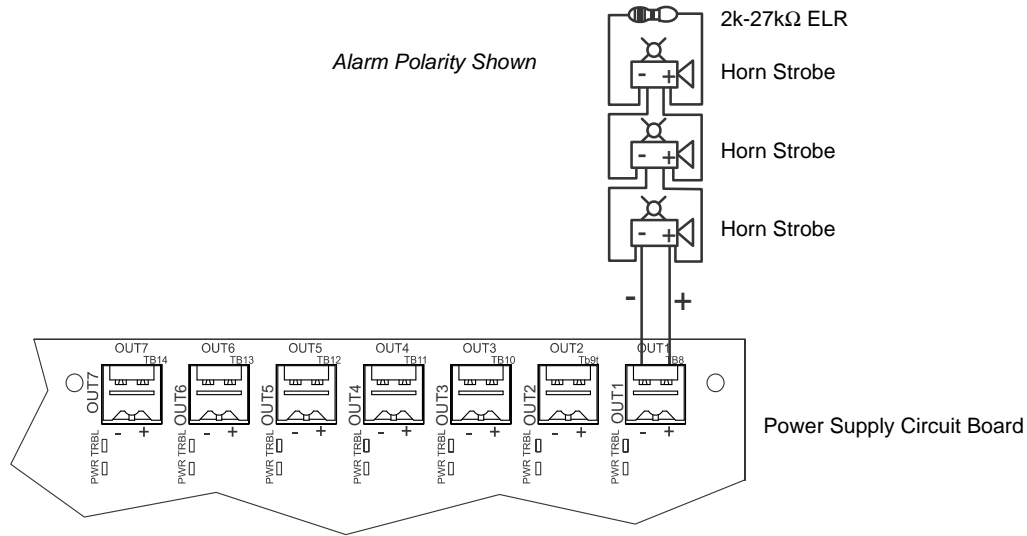

Figure 2.2 NAC Class B

2.2.2 ZNAC-PS Class A Option Module

The ZNAC-PS is an optional Class A conversion module which mounts to connector J8 on the upper right side of the circuit board. This module allows the 6 amp power supply or 10 amp power supply to support Class A Notification Appliance Circuits on all outputs. Class A *power* supervision is also supported on output circuits #1 and #2 when either of these outputs are configured as resettable or non-resettable auxiliary power. ZNAC-PS SW1 and SW2 settings *must* match the power supply’s output 1 and 2 settings to ensure proper supervision.

Two slide switches are located on the right side of the ZNAC-PS module to properly configure output circuits #1 and #2 for either NAC or Auxiliary Power operation, as described below. Note that there are no slide switches for the remaining outputs as these outputs do not support Class A power supervision.

- For output #1, set the upper switch to either “NAC1” or “AUX1” depending on the intended operation.
- For output #2, set the lower switch to either “NAC2” or “AUX2” depending on the intended operation.



NOTE: Class A supervision and the ZNAC-PS module are not intended for use with door holder operation.

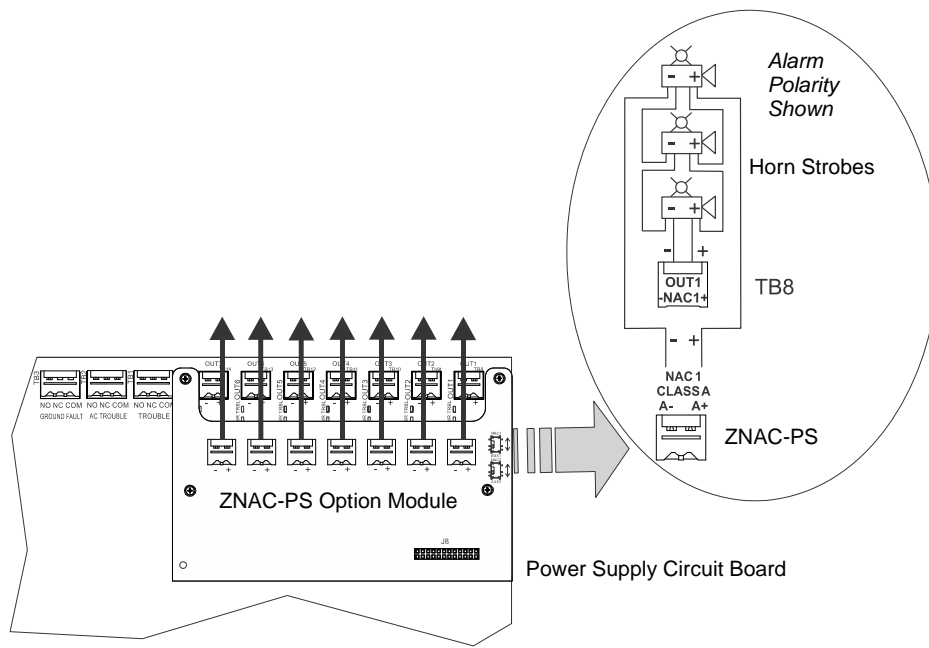

Figure 2.3 Class A NACs using ZNAC-PS Option Module

2.3 Addressable Module Mounting

The power supply has been designed to allow the mounting of an addressable control, relay, or monitor module on the main circuit board inside the power supply cabinet. This allows power to be fed from the power supply’s output circuit directly to the module, without running the power wires outside the cabinet. Remove mounting screws from the positions indicated below and replace with standoffs (included in hardware kit). Mount the module over the standoffs and secure with screws.

Compatible modules include the System Sensor single- and multi-point modules branded for the FACP. Refer to the *SLC Wiring Manual* for the brand of FACP.

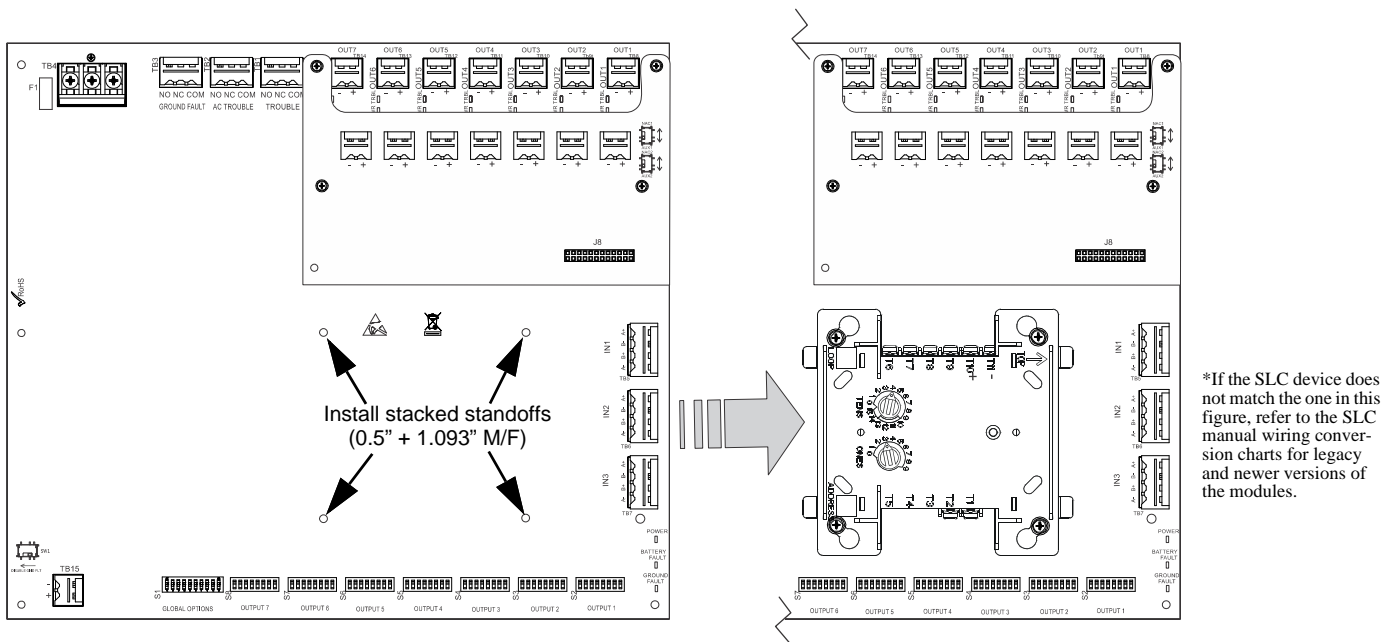
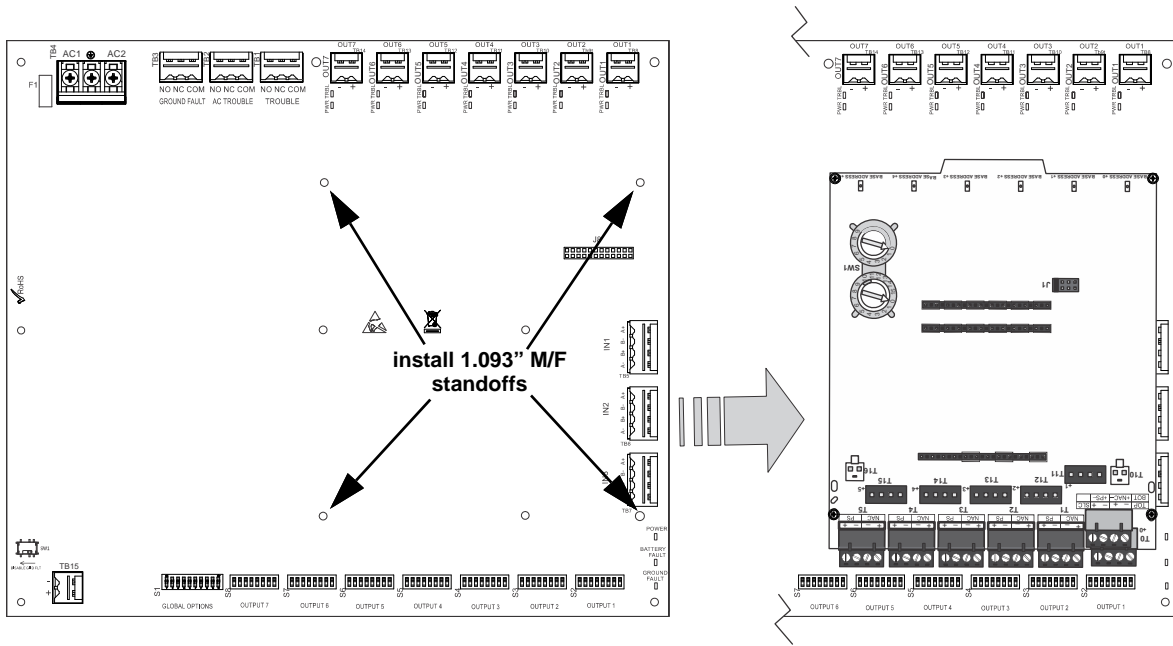

Figure 2.4 Mounting a Single Module in the Power Supply Cabinet



Note: For instructions on mounting a multi-module and a ZNAC-PS module, refer to the *ZNAC-PS Install Sheet #LS10228-000GE-E*. The multi-module *must* be installed upside down when the ZNAC-PS is installed. If the ZNAC-PS is *not* installed, the multi-module may be mounted in either direction.

Figure 2.5 Mounting a Multi-Module in the Power Supply Cabinet

2.4 NEC Power-limited (Class 2) Wiring Requirements

Power-limited (Class 2) and non-power-limited circuit wiring must remain separated in the cabinet. All power-limited (Class 2) circuit wiring must remain at least 0.25" away from any non-power-limited circuit wiring and all power-limited (Class 2) circuit wiring and non-power-limited circuit wiring must enter and exit the cabinet through different conduits. One such example of this is shown below. Any conduit knockouts may be used. For power-limited (Class 2) applications, use of conduit is optional.

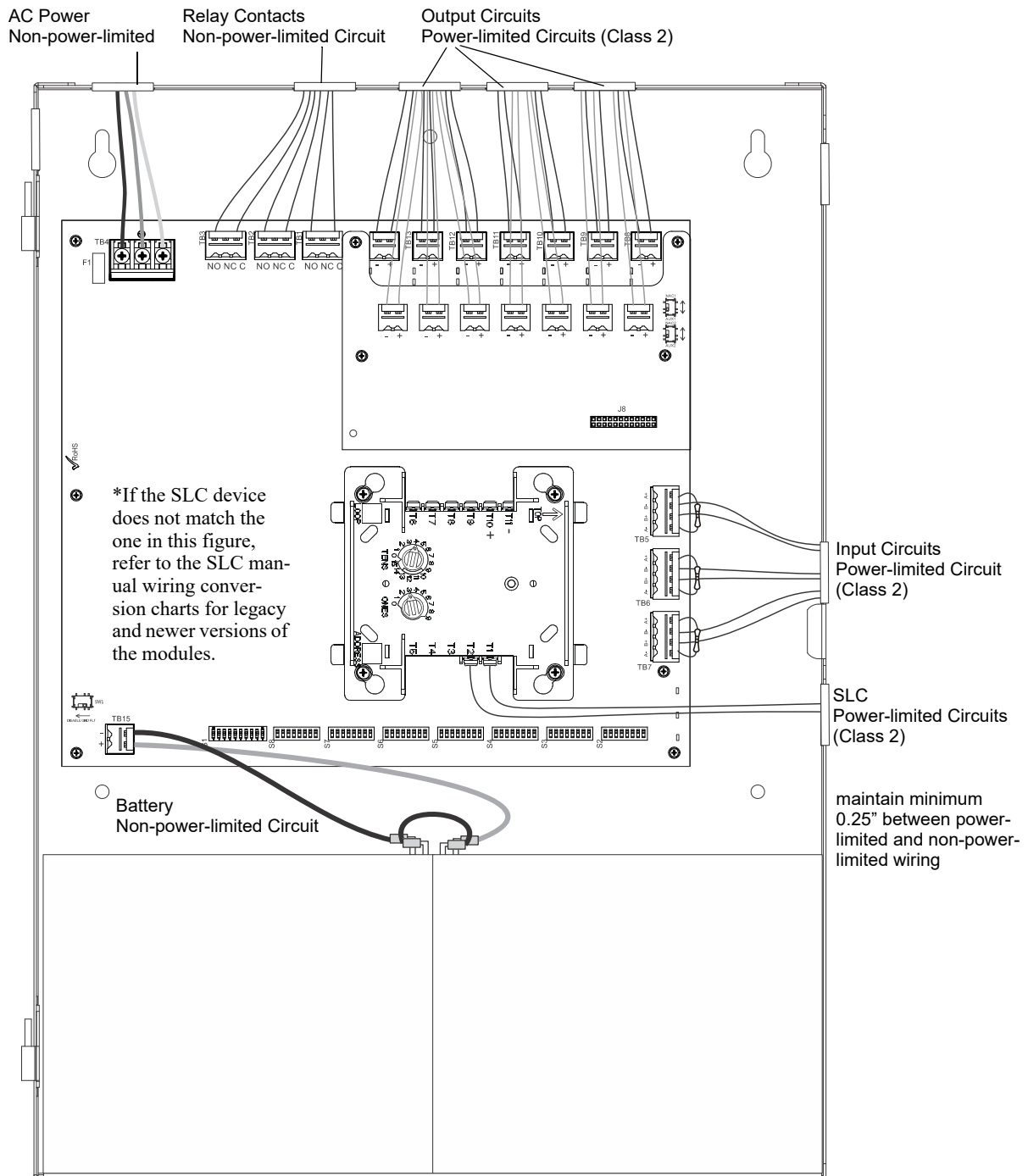

Figure 2.6 Power-limited (Class 2) Wiring Example

2.5 FACP with the Power Supply in Slave Configuration

In this application, the power supply is configured as a Slave unit and connected to a master FACP programmed for synchronized output. .

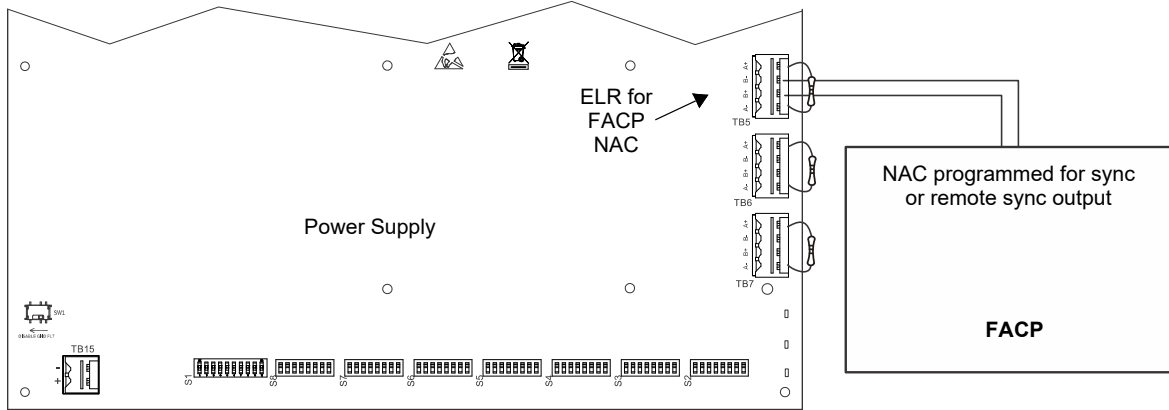

Figure 2.7 Supervised Master/Slave Connections

The following notes apply to Figure 2.7 on page 17

1. Refer to NFPA 72, Chapter 4-4, Visible Characteristics, Public Mode.
2. Use only devices from the same manufacturer in each system.
3. Set Output DIP Switch: position 3=ON, 4 = OFF, 5 = ON, 6 = OFF.
4. If the FACP has a dedicated sync output connector, wire the remote sync output connector to Input #1 terminals 2 and 3.
5. In this example, the output is mapped to Input#1 in Slave Configuration, but it can be programmed to another input using the DIP switches.
6. For NFPA 72 compliance, notification appliances cannot be installed on the FACP control circuit connecting to the power supply's input circuits.

2.6 Power Supply in Master Configuration Connected to FACP

In this application, a master power supply, set for synchronization, is connected to an FACP with non-synchronized output.

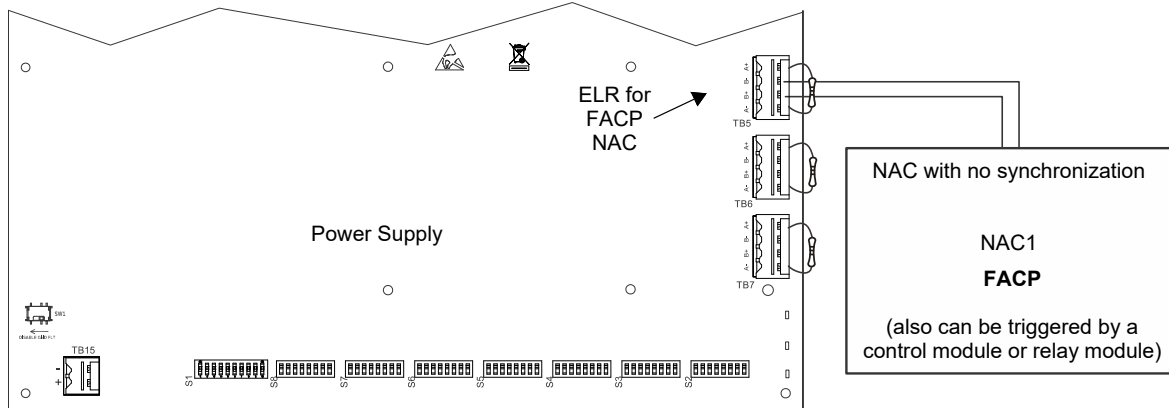

Figure 2.8 Supervised FACP to Master Connections (non-synchronized source)

The following notes apply to Figure 2.8.

1. Refer to NFPA 72, Chapter 4-4, Visible Characteristics, Public Mode.
2. Set Output DIP switches to the desired sync protocol as described below. Refer to the *Device Compatibility Document* for devices.

DIP Switch Position				Synchronization Type
3	4	5	6	
OFF	ON	ON	OFF	Master Configuration - ANSI Temporal (Temporal 3)
ON	ON	ON	OFF	Master Configuration - CO Temporal (Temporal 4)
OFF	OFF	OFF	ON	Master Configuration - Amseco/Potter
OFF	ON	OFF	ON	Master Configuration - Gentex
OFF	OFF	ON	ON	Master Configuration - System Sensor
OFF	ON	ON	ON	Master Configuration - Wheelock
ON	OFF	OFF	ON	Master Configuration, Selective Silence - Amseco/Potter
ON	ON	OFF	ON	Master Configuration, Selective Silence - Gentex
ON	OFF	ON	ON	Master Configuration, Selective Silence - System Sensor
ON	ON	ON	ON	Master Configuration, Selective Silence - Wheelock

3. Use only devices from the same manufacturer in each zone or field of view.
4. In this example, the output is mapped to Input#1 in Master Configuration, but it can be programmed to another input using the DIP switches.
5. For NFPA 72 compliance, notification appliances cannot be installed on the FACP control circuit connecting to the power supply's input circuits.

2.7 Connecting to an External Charger

The Power Supply can be connected to an external charger to charge systems requiring over 33AH batteries. Ensure all power has been disconnected before wiring. Observe polarity when making connections. Wiring must be in conduit within 20 feet (6.096m) in the same room.

2.7.1 CHG-120

1. Set S1 position 4 on the power supply to the OFF position to disable the onboard battery charger.
2. Connect the battery cables between TB15 (+ and -) on the power supply and the CHG-120 charger output circuit (TB2: Out 1+ and Out 1-) as shown in Figure 2.9. Be certain to observe polarity.
3. Connect the batteries to the charger.
4. Connect the battery interconnect cable only after AC power is applied and batteries are connected. Refer to the *CHG-120 Manual* for more information.
5. Cut and remove Jumper R104 on the CHG-120 to disable ground fault supervision.

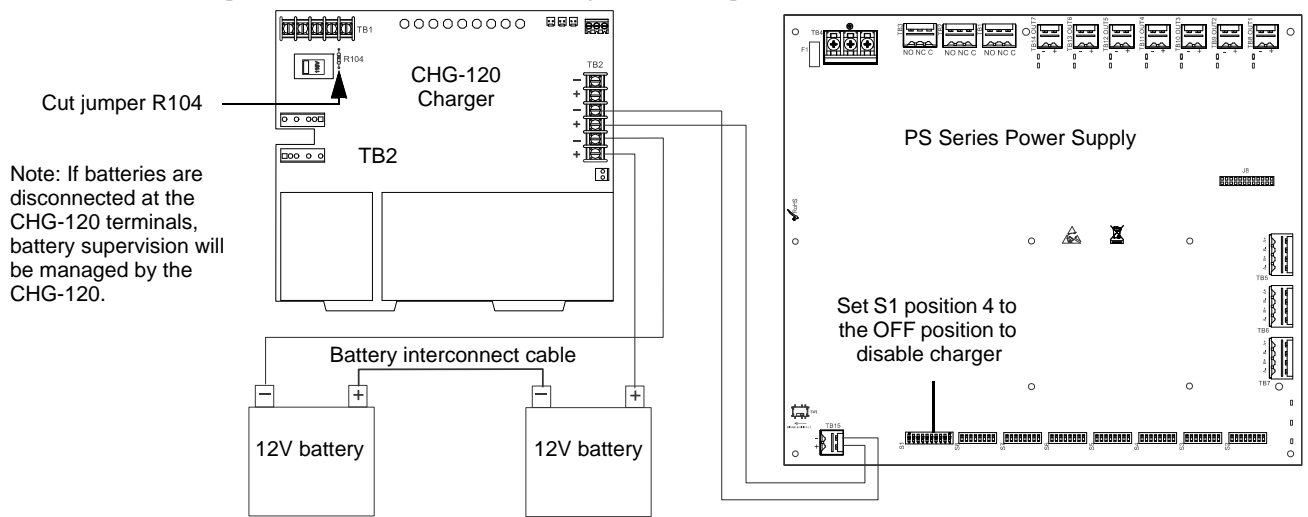

Figure 2.9 Connecting the Power Supply to a CHG-120 Charger

2.7.2 CHG-75

1. Set S1 position 4 on the power supply to the OFF position to disable the onboard battery charger.
2. Connect the battery cables between TB15 (+ and -) on the power supply and the CHG-75 charger output circuit (TB2: Out+ and Out-) as shown in Figure 2.10. Be certain to observe polarity.
3. Connect the batteries to the charger.
4. Connect the battery interconnect cable only after AC power is applied and batteries are connected. Refer to the *CHG-75 Manual* for more information.
5. Cut and remove Jumper JP2 on the CHG-75 to disable ground fault detection.

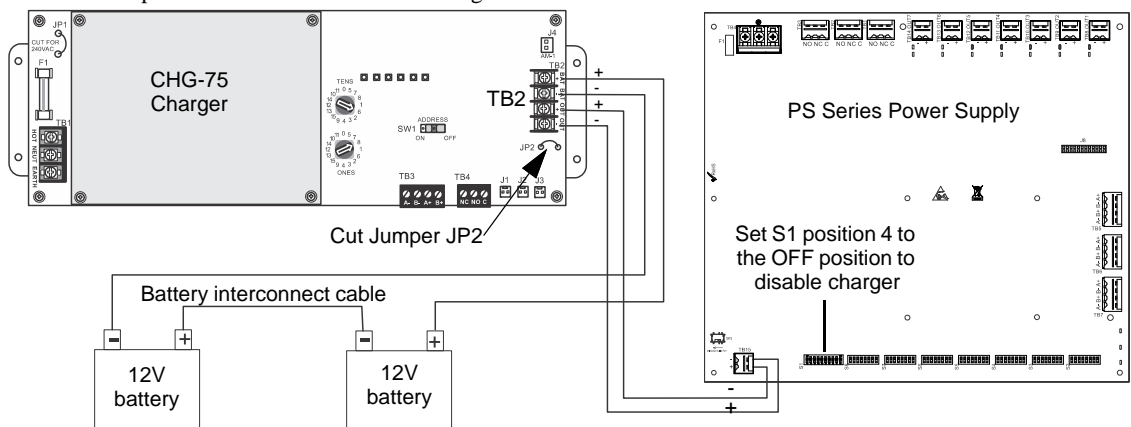

Figure 2.10 Connecting the Power Supply to a CHG-75 Charger

2.8 Connecting Multiple Power Supplies

2.8.1 Cascading Multiple Units

Up to four power supplies can be cascaded together to provide additional NAC extenders for a system. Maintain separation of power-limited and non-power-limited wiring as shown in Figure 2.6 on page 16.

Figures 2.11 and 2.12 show the controlling signal connected to Input 1 of power supply #1. However, typically any available Input of power supply #1 can be used.

Figures 2.11 and 2.12 show NAC7 of power supply #1 - power supply #3 as the cascading output. However, any available Output of power supply #1 – power supply #3 can be used.



NOTE: Any configuration that requires an additional control signal (i.e. a trigger signal), such as Selective Silence or Input #1 Sync Configuration, will affect which Inputs may be available on PSE1 for use with cascading. (Triggers signals are usually assigned to Input 2.) Refer to those sections of the manual for specifics.

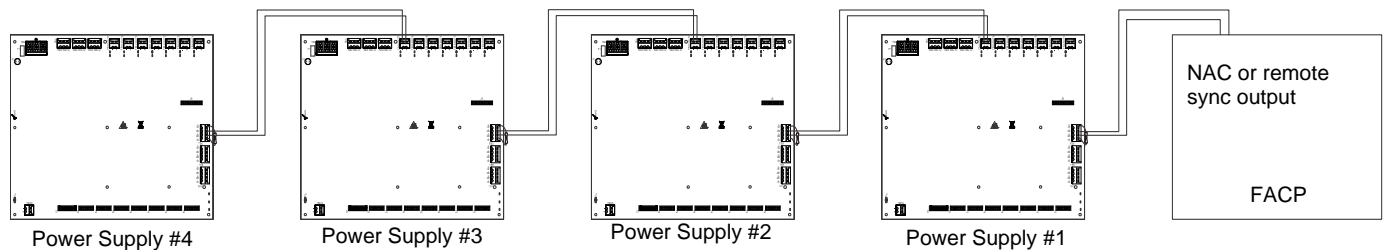

Figure 2.11 System Sync Connections Triggered by FACP - Cascade

The following notes apply to Figure 2.11.

1. Set all power supply units to Slave (sync follower) Configuration.
2. The debounce/dejitter setting must be set to 1 msec on all cascaded units. See Table 3.3 on page 24.
3. For NFPA 72 2019 compliance, notification appliances cannot be installed on the interconnecting FACP control circuits wired to the power supply's input circuits.
4. The total line impedance for interconnected units cannot be such that it creates a voltage drop > 3.2 VDC.
5. In Default mode, ground fault supervision is provided via the dedicated ground fault relay. For ground fault supervision in Retrofit mode, refer to Table 5.1 and Section 5.4. Refer to Section 2.10 for different methods of ground fault monitoring for the power supply.

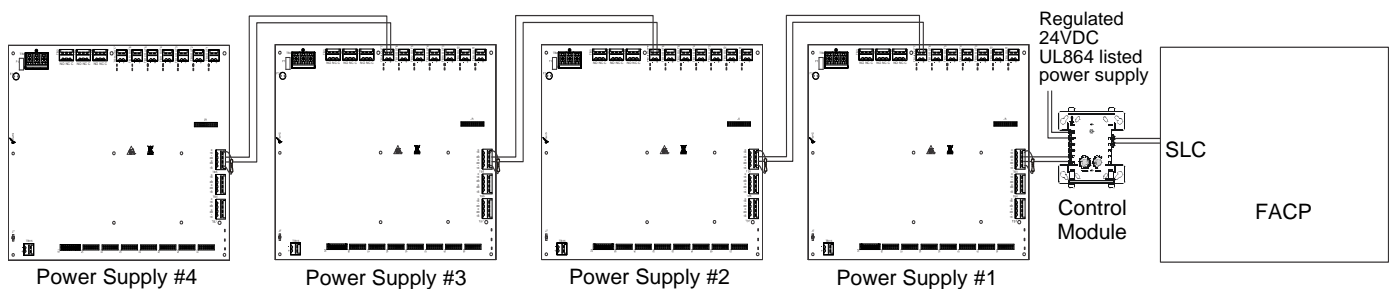

Figure 2.12 System Sync Connections Triggered by Control Module - Cascade

The following notes apply to Figure 2.12.

1. Set Power Supply #1 to Master configuration, and the desired strobe/horn type. Set remaining power supply units to Slave (sync follower) configuration.
2. The debounce/dejitter setting must be set to 1 msec on units power supply #2 – power supply #4. See Table 3.3 on page 24.
3. Strobe/Horn devices connected to the power supply units are not guaranteed to be in sync with FACP devices when using this configuration.
4. For NFPA 72 2019 compliance, notification appliances cannot be installed on the interconnecting FACP control circuits wired to the power supply's input circuits.
5. The total line impedance for interconnected units cannot be such that it creates a voltage drop > 3.2 VDC.
6. In Default mode, ground fault supervision is provided via the dedicated ground fault relay. For ground fault supervision in Retrofit mode, refer to Table 5.1 and Section 5.4. Refer to Section 2.10 for different methods of ground fault monitoring for the power supply.

2.8.2 Daisy-chaining Multiple Units

The number of power supplies which can be daisy-chained is limited by the line resistance and current draw limitations of the upstream module or NAC output circuit. Refer to the module, power supply, or fire alarm control panel manual to confirm these circuit specifications. Maintain separation of power-limited and non-power-limited wiring as shown in Figure 2.6.

Figure 2.13 shows the controlling signal connected to Input 1 of power supply #1. However, typically any available Input of power supply #1 can be used.

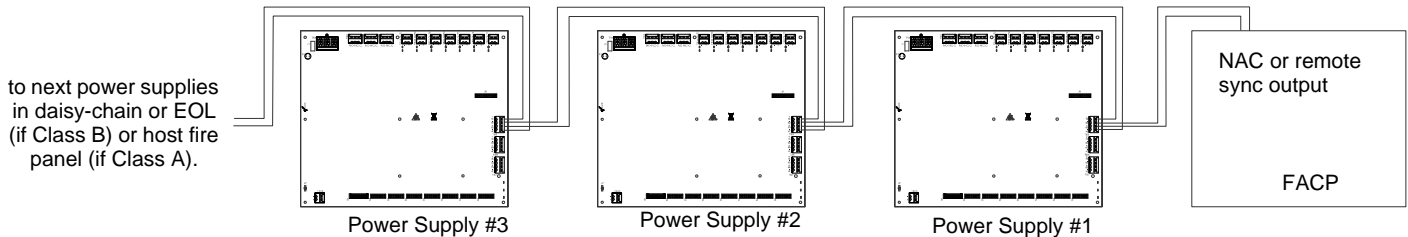

Figure 2.13 System Sync Connections Triggered by FACP - Daisy-chaining

The following notes apply to Figure 2.13.

1. The power supply units can be set to work in either Default or Retrofit modes. In standby condition, the input EOL relays are open when they are used to report troubles, depending on the configured operating mode. Refer to Table 5.1 on page 33. In alarm condition, all inputs will close their EOL relays to allow the daisy-chaining of input signals.
2. The debounce/dejitter setting must be set to a value that allows the correct detection of input signals. See Table 3.3 on page 24.
3. In Default mode, ground fault supervision is provided via the dedicated ground fault relay. For ground fault supervision in Retrofit mode, refer to Table 5.1. Refer to Section 2.10 for different methods of ground fault monitoring of the power supply. The NAC circuit or remote sync output is to be monitored by the host FACP. For daisy-chaining power supplies in Canadian applications, Input #1 should be configured as a sync input with the trigger at Input #2 or #3 for proper ground fault supervision

2.9 Canadian Applications

Installation shall be in accordance with ULC S524. Wiring methods shall be in accordance with CSA C22.1, Safety Standard for Electrical Installations, Canadian Electrical Code, Part I, Section 32.



NOTE: Mass Notification is not for use in Canadian applications.

Canadian applications, per ULC, require the following:

- Using hardware kit #50152254-001, purchased separately, connect the AC ground wire to the Ground Stud located at the top left of the backbox as shown below. Connect the incoming earth ground wire to supplied cable #71073 with a wire nut. Position the ring terminal end over the grounding stud. Secure with one of the keps nuts. Place the ring terminal from the other supplied ground cable #71073 over the ground stud and secure with the second keps nut. Wire the ground cable to the middle position of TB4. Ensure that the ground for incoming AC mains is the first wire installed, closest to the backbox. This connection is vital in reducing the panel's susceptibility to transients generated by lightning and electrostatic discharge. Apply AC power to the panel only after the system is completely installed and visually checked. *Note that AC power must be applied to the panel before installing the battery interconnect cable.*

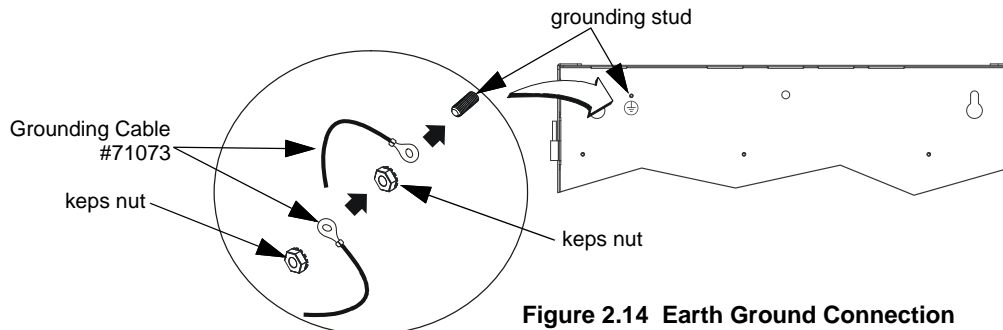

Figure 2.14 Earth Ground Connection

- Refer to Section 5.1 for instructions to meet ULC requirements for trouble monitoring of each zone.

2.10 Ground Fault Detection

When connected to an FACP, the host FACP must monitor for all ground fault conditions.

There are three ways to monitor for ground faults in the power supply when cascading (up to four) or daisy-chaining power supplies.

1. The negative (-) battery terminal of the power supply must be connected to the negative (-) battery terminal of the host FACP. Battery wiring is non-power-limited. Power-limited and non-power-limited wiring must be wired with a minimum of 0.25" spacing in between and enter/exit through different knockouts. When cascading multiple power supply units, continue connecting the negative battery

terminals, including FACP battery terminal. Ground faults must then be detected by the first power supply in the chain. Disable ground fault detection on other power supply units by sliding SW1 to the left. Ensure ground fault detection is enabled on power supply #1, the first power supply from the FACP, by sliding SW1 to the right. 18 AWG wire minimum must be used.

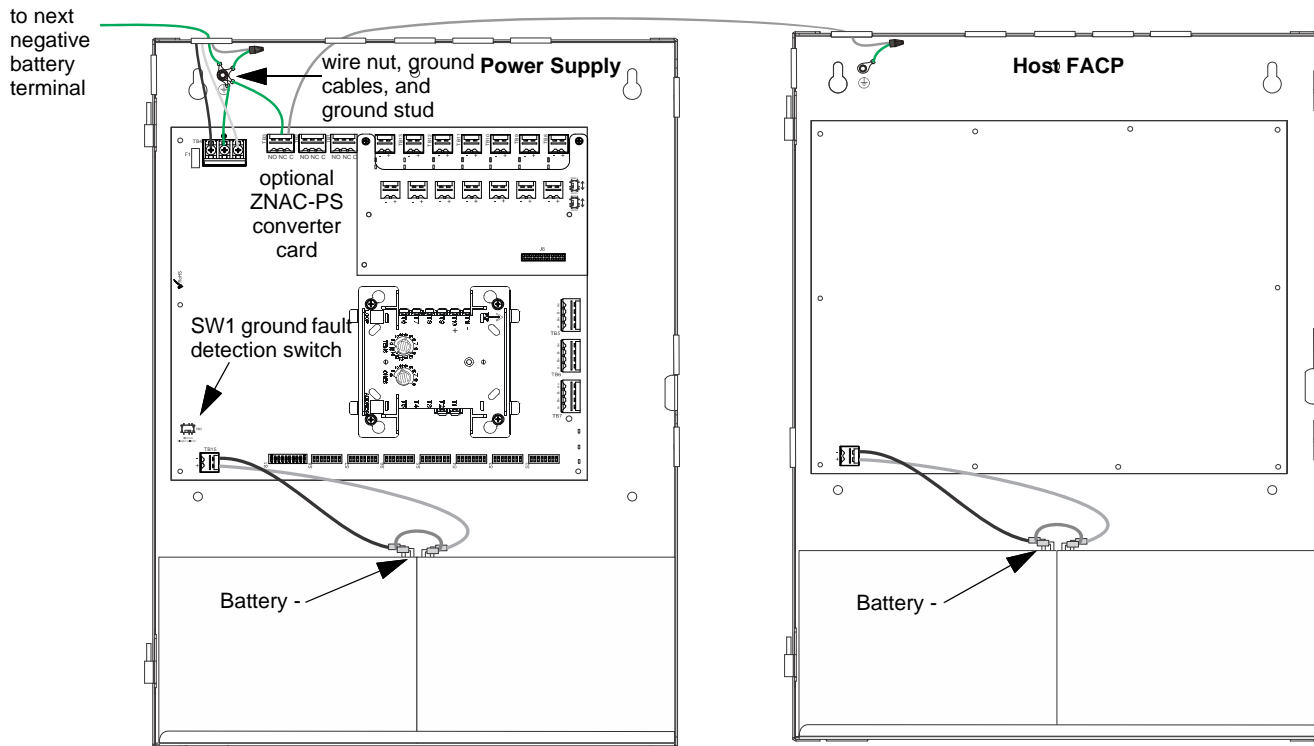

Figure 2.15 Ground Fault Detection Option 1

- Ground fault monitoring may be accomplished by mapping an annunciator point on a UL 864-/ULC S527-listed FACP as ground fault. The annunciator shall be wired adjacent to the FACP so all displays are grouped for viewing and operation by one person. Addressable FACP: The FACP must be programmed to turn on the common trouble LED, trouble tone, and a separate yellow annunciator point when the monitor module connected to the power supply ground fault relay is initiated. The annunciator point must also be labeled as “XXX Ground Fault” where “XXX” describes ground fault origin.

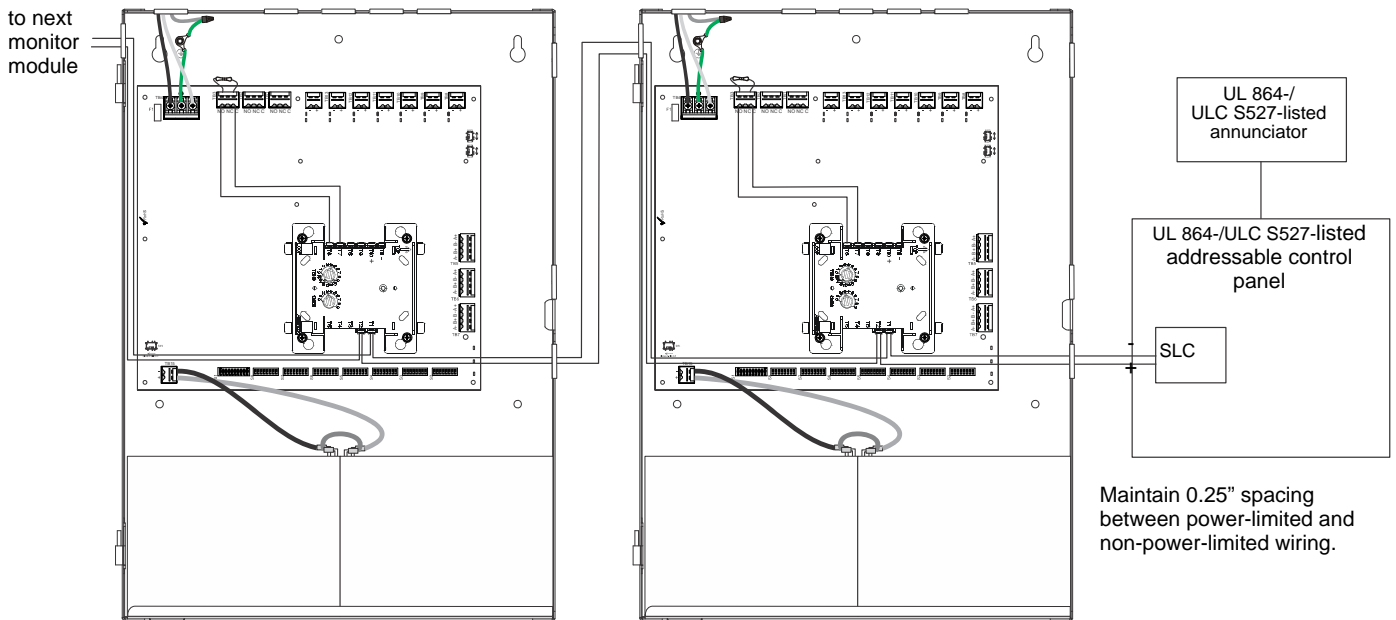

Figure 2.16 Ground Fault Detection Option 2 - Addressable FACP

3. Conventional FACP: The FACP must be programmed to turn on the common trouble LED, trouble tone, and a separate yellow annunciator point when the input connected to the power supply ground fault relay is initiated. Use one input per power supply.

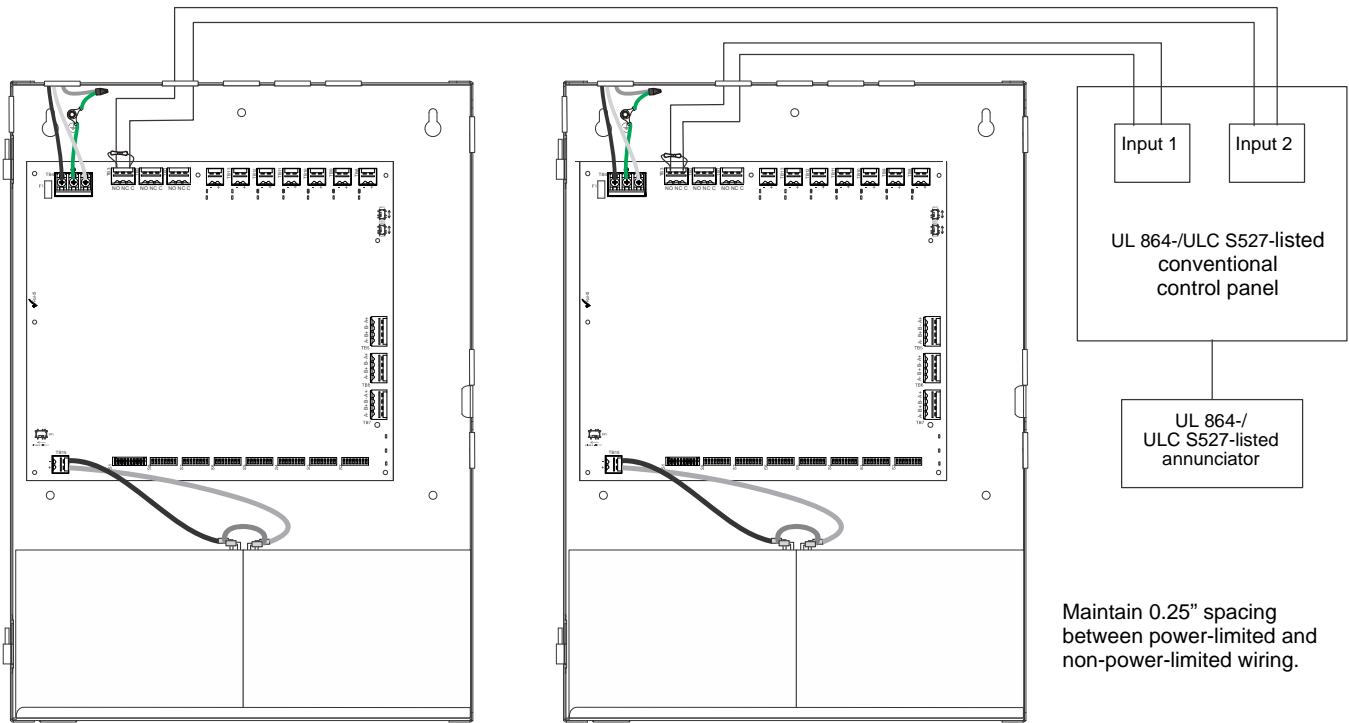

Figure 2.17 Ground Fault Detection Option 3 - Conventional FACP

Section 3: Programming Options

NOTICE TO USERS, INSTALLERS, AUTHORITIES HAVING JURISDICTION AND OTHER INVOLVED PARTIES				
This product incorporates field-programmable software. In order for the product to comply with the requirements in the Standard for Control Units and Accessories for Fire Alarm Systems, UL 864, certain programming features or options must be limited to specific values or not used at all as indicated below:				
Program feature or option	Permitted in UL864/2572 and ULC S527? (Y/N)	Possible settings	Settings permitted in UL 864 / UL2572	Settings permitted in ULC S527
Door Holder Dropout Delay	Y	Refer to “AC Loss Door Holder Dropout Timer” on page 25. <ul style="list-style-type: none"> • Does not drop • 15 seconds • 5 minutes • 60 seconds 	<ul style="list-style-type: none"> • Does not drop • 15 seconds • 60 seconds • 5 minutes 	<ul style="list-style-type: none"> • Does not drop • 15 seconds • 60 seconds • 5 minutes
AC Loss Delay Timer	Y	Refer to “AC Fail Indication Delay” on page 26. <ul style="list-style-type: none"> • 30 hours • 12 hours • 2 hours • none 	<ul style="list-style-type: none"> • 2 hours¹ • none 	<ul style="list-style-type: none"> • 2 hours • none
Operating Mode	Y	Refer to “Operating Modes” on page 26. <ul style="list-style-type: none"> • Retrofit Mode • Change Output Circuit Configurations • Display Trouble History • Default Mode 	<ul style="list-style-type: none"> • Default Mode² 	<ul style="list-style-type: none"> • Default Mode

Table 3.1 Agency-Permitted Programming Settings

- 1 A two hour delay is only permitted on an addressable FACP.
- 2 For site compliance to UL864 10th Edition/ULC-S527 4th Edition, all power supplies must be configured for Default Mode.

This section describes the programming options available via DIP switch settings. The power supply can be field programmed using DIP switches S1-S8 which are located at the bottom of the circuit board. S1 controls the global options of the power supply and S2-S8 control the functions of each output circuit, respectively. Refer to the following illustration for switch locations and DIP switch placement in the ON and OFF positions.

Important: Activate output DIP switch changes by setting S1 positions 9 and 10 appropriately. Refer to Table 3.8 on page 27 for DIP Switch programming settings.

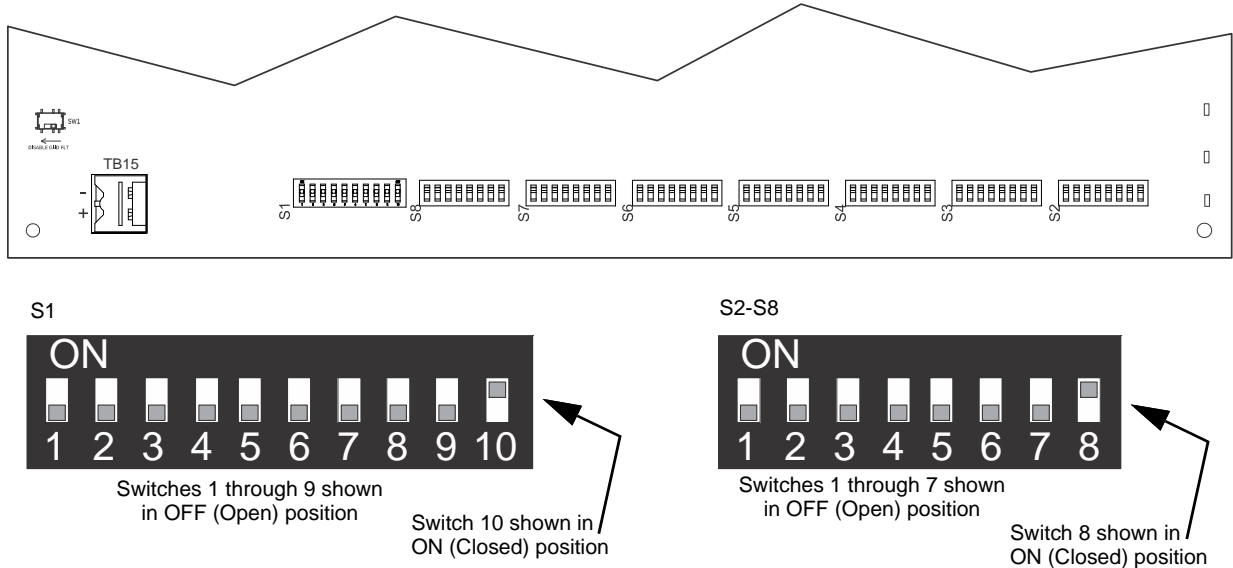

Figure 3.1 Field Programming DIP Switches

Command Input #1

Power supply Output circuits can be configured to “follow” a sync pattern that is input to Command Input #1 (TB5), either immediately (Input#1 Normal Configuration), or only after a trigger signal (Input #1 Sync Configuration) is applied at Command Input #2 (TB6) or Command Input #3 (TB7), if applicable. In Input #1 Sync Configuration, an output circuit will only output the Command Input #1 sync pattern when Command Input #2 (or Command Input #3 on the power supply) is receiving a valid (9V - 32V) trigger signal.

- Input #1 is dedicated as the follower input for any synchronization signal received into this input. Do not apply the **trigger** signal to this input.
- Input #2 is used for the trigger input for either the 6 amp or 10 amp models. Do not apply the **synchronization** signal to this input.
- Input #3 can also be used for the trigger input, but is only available on the 10 amp model. Do not apply the **synchronization** signal to this input.
- Use only one input (Input #2 or #3) at any one time for the trigger input. When using the Global DIP switch S1 #1 and #2 = ON,ON, both Input#2 and Input#3 will be used as the trigger input.
- A trigger signal between 9-32VDC is required for proper operation.

If the sync signal is lost in Input#1 Normal Configuration or only the trigger signal is present at Input#2 or #3 in Input#1 Sync Configuration, the output circuit behavior will depend on the operating mode configuration:

- **In Default Mode (Input#1 Normal Configuration, S1 DIP switch 3 ON, 9 ON, 10 ON):**
 - If there is no sync signal, the NAC output circuits will be turned OFF immediately.
 - If the sync signal is suddenly lost (due to wiring failure), the power supply will turn NACs OFF immediately until a sync signal appears.
 - If the sync signal becomes active after being previously lost (while the trigger signal is ON), the outputs will immediately follow the Sync signal and NAC configurations.
- **In Default Mode (Input#1 Sync Configuration, S1 DIP switch 3 OFF, 9 ON, 10 ON):**
 - If there is no sync signal at Input #1, the NAC output circuits will be turned OFF immediately, even if there is a trigger signal at input #2 or Input#3.
 - If the sync signal is suddenly lost at Input #1 (due to wiring failure), the power supply will turn NACs OFF immediately, even if there is a trigger signal at input #2 or Input#3, until a sync signal appears.
 - If the sync signal becomes active after being previously lost, the outputs will immediately follow the Sync signal (provided the trigger is present at Input#2 or Input#3) and NAC configurations.
- **In Retrofit Mode (Input#1 Normal configuration, S1 DIP switch 3 ON, 9 OFF, 10 OFF):**
 - If there is no sync signal, the NAC circuits will be turned off immediately.
 - If the sync signal is suddenly lost (due to wiring failure), the power supply will turn NACs off immediately until a sync signal appears.
 - If the sync signal becomes active after being previously lost (while the trigger signal is on), the outputs will immediately follow the sync signal and NAC configurations.
- **In Retrofit Mode (Input#1 Sync Configuration, S1 DIP switch 3 OFF, 9 OFF, 10 OFF):**
 - The sync signal is monitored continuously and is declared lost if the signal is off for 3 consecutive seconds. The sync signal is declared restored (after being previously lost) after it is back on.
 - If the trigger signal is activated while the sync signal is in lost state, the power supply will turn NACs on steady with no sync until the sync signal is restored. The NACs will turn off when the trigger input becomes inactive.
 - If the sync signal goes missing while the trigger signal is active, the power supply will turn NACs off until the sync goes into Sync Lost state (3 sec). After the three seconds, the power supply will turn NACs on steady with no sync.
 - If the sync signal goes into the restore state after being previously lost while the trigger signal is active, the outputs will follow the sync signal and NAC configurations.

Charger Enable/Disable

The power supply’s battery charger can be disabled to accommodate an external battery charger, such as the CHG-75 or CHG-120. Setting DIP switch position 4 to the OFF position will disable the charger. Setting DIP switch position 4 to the ON position will enable the charger. It should only be disabled if an external battery charger is being used for the power supply.

AC Loss Door Holder Dropout Timer

Any output can be configured as a NAC, aux power, or door closer circuit. Configuring an output circuit as a door closer circuit will provide a steady 24 VDC to door holders until an alarm condition or an AC fail condition. Upon an alarm condition, power to door holder circuits will be removed, causing doors to close immediately. During an AC fail condition, the door holder will remain energized until the programmed AC fail indication delay expires. Programmed delays are only applicable to AC loss conditions. Refer to Table 3.1 for UL-compliant settings.

DIP switch positions 5 and 6 are used to select the door holder dropout timer as listed below:

Position 5	Position 6	Door holder dropout delay after AC loss
OFF	OFF	Power does not drop out with AC loss
ON	OFF	5 minutes
OFF	ON	60 seconds
ON	ON	15 seconds

Table 3.4 Door Holder Dropout Settings

AC Fail Indication Delay

The AC Fail Indication Delay feature provides the option to delay generation of a trouble signal upon the loss of AC power. Refer to Table 3.1 for UL-compliant settings.

■ Default Mode

When using the power supply in Default Mode: DIP switch positions 7 and 8 are used to select the AC Fail Indication Delay as listed below:

Position 7	Position 8	AC Fail Indication Delay
OFF	OFF	30 hours
ON	OFF	12 hours
OFF	ON	2 hours
ON	ON	none

Table 3.5 AC Loss Delay Settings: Default Mode

■ Retrofit Mode

When using the power supply in Retrofit Mode: DIP switch position 7 is used to select the AC Fail Indication Delay as listed below:

Position 7	AC Fail Indication Delay
OFF	2 hours
ON	none

Table 3.6 AC Loss Delay Settings: Retrofit Mode

DIP switch position 8 is used to select which trouble relays will report any AC and ground faults.

Position 8	AC Fail/Ground Fault Indication
OFF	AC faults and ground faults are reported either by the Input #1 EOL relay or Input #2 EOL relay (if Input#1 is configured as sync) and by the General Trouble relay
ON	AC faults are reported only by the AC Trouble relay and ground faults will be reported only by the Ground Fault Trouble relay.

Table 3.7 AC Fail/Ground Fault Indication: Retrofit Mode

Refer to “AC Trouble Relay” on page 35, for operation of internal NAC trouble relay in response to AC loss.

Operating Modes

The power supply operates primarily in Default Mode or Retrofit Mode, depending on the installation. While in either mode, the power supply can be placed in two special, temporary operating modes per settings described in Table 3.8. These modes are Change Output Circuit Configurations and Display Trouble History. *Upon completion of either of these two modes, the system must be placed back in Default or Retrofit operating mode. Note that the current operation of all outputs will not be affected or disturbed while in either of these two special operating modes.*



NOTE: When switching between Default and Retrofit modes, go to Change Output Circuit Configurations mode first (and remain there for at least 1 second) and then move to the desired new mode (even if nothing is changed in the DIP switch settings). This will ensure that the operating mode is updated.

■ Default Mode

This is default operating mode of the power supply (the mode configured when the unit is shipped), and is compliant with UL 864 10th Edition standards. Operation of the power supply will be detailed in Default Mode unless otherwise specified.

■ Retrofit Mode

This mode is an alternative to Default Mode, to be used for legacy/existing installations

Note that when the power supply is configured for use in Retrofit Mode, the FACP should be monitoring either Input #1/Input #2 end-of-line relay or the General Trouble relay, but not both.

In Retrofit Mode, output 1 will blink as visual indication that the panel is operating in Retrofit Mode. Refer to Section 4 for details on LED patterns.

■ Change Output Circuit Configurations Mode



NOTE: DIP switch settings may be changed to the desired configuration either before or after entering Change Output Circuit Configurations Mode.

1. Enter this mode via the setting shown in Table 3.8. Once entered, the Output trouble LEDs will continually flash from right to left to confirm the power supply is in Change Output Configuration Mode.
2. Configure settings on the Output DIP switches as needed (see Note above).
3. Return to Default or Retrofit Mode via DIP switches settings for 9 and 10 as shown in Table 3.8 below. The output trouble LEDs will stop the flash pattern described above to confirm Default or Retrofit Mode has been restored.

■ **Display Trouble History Mode**

To see past troubles on the system, place position 9 to OFF and position 10 to ON. Refer to Section 4 for descriptions of troubles. Trouble history will be erased upon exiting the Display Trouble History operating mode.

The behavior of the Display Trouble History Mode with regard to the Sync Input Configuration and Trouble reporting will depend on which was the last active (minimum 5 minutes) operating mode, Default or Retrofit, before entering Display Trouble History Mode.

DIP switch positions 9 and 10 are used to select the type of operating mode as listed below:

Position 9	Position 10	Operating Mode
OFF	OFF	Retrofit Mode
ON	OFF	Change output circuit configurations
OFF	ON	Display Trouble History
ON	ON	Default Mode

Table 3.8 Operating Mode

3.2 Output Circuit Control DIP Switch Settings

Each output circuit has its own programming DIP switch. DIP switches S2-S8 are labeled on the PCB to indicate which output circuit it is controlling. Output circuits are labeled at the top of the PCB, TB8-TB14. The following table applies to DIP Switches S2-S8.

Important! If an output circuit is overloaded, the output will shut off and generate a trouble signal. If this happens, the power supply will need to be reset manually. Either reset circuit configurations by toggling switch S1 position 10 to the OFF position for a minimum of five seconds or turn off primary and secondary power and reapply to the power supply.

DIP Switch Position				Output Control Setting/Operation
1	2			
OFF	OFF			NAC output will activate when Command Input #1 is activated. <i>Do not use this setting when Input#1 is set to Sync Configuration.</i>
ON	OFF			NAC output will activate when Command Input #2 is activated. (Exception: this Input controls Horn silencing during Selective Silence operation.)
OFF	ON			NAC output will activate when Command Input #3 is activated, if available. <i>(If accidentally programmed on a 6 amp power supply, the system will default to Input #2.)</i>
ON	ON			NAC output will activate when ANY Command Input is activated. <i>If Input #1 is set to Sync Configuration (Global DIP switch 3 = OFF), this setting applies to Input#2 and Input#3 only.</i>
3	4	5	6	Output Control Setting/Operation
OFF	OFF	OFF	OFF	Unused/Unsupervised. Outputs will not activate. <i>Factory default setting.</i>
ON	OFF	OFF	OFF	Reserved- Outputs will not activate
OFF	ON	OFF	OFF	Non-resettable auxiliary power
OFF	OFF	ON	OFF	Resettable aux power
ON	ON	OFF	OFF	Door holder auxiliary power
ON	OFF	ON	OFF	Slave Configuration (NAC follower)
OFF	ON	ON	OFF	Master Configuration - ANSI Temporal (Temporal 3)
ON	ON	ON	OFF	Master Configuration - CO Temporal (Temporal 4)
OFF	OFF	OFF	ON	Master Configuration - Amseco/Potter
OFF	ON	OFF	ON	Master Configuration - Gentex
OFF	OFF	ON	ON	Master Configuration - System Sensor
OFF	ON	ON	ON	Master Configuration - Wheelock
ON	OFF	OFF	ON	Master Configuration, Selective Silence - Amseco/Potter
ON	ON	OFF	ON	Master Configuration, Selective Silence - Gentex
ON	OFF	ON	ON	Master Configuration, Selective Silence - System Sensor
ON	ON	ON	ON	Master Configuration, Selective Silence - Wheelock
				7 Output Control Setting/Operation (Only applies when ZNAC-PS is installed)
				OFF Class B
				ON Class A
				8 Output Control Setting/Operation (Unused)
				OFF Unused/Unassigned
				ON Unused/Unassigned

Table 3.9 S2-S8 Output Circuit DIP Switch Settings

3.2.1 Output Circuit Programmable Features Description

Command Inputs/NAC Circuit Activation

The power supply allows for individual NAC circuit programming. Each NAC can be configured to activate based on the settings selected for up to 3 command inputs.

Set DIP switch positions 1 and 2 according to which input circuit is used as the trigger input for the coordinating configuration as shown below.

Position 1	Position 2	Default Normal	Default Sync	Retrofit Normal	Retrofit Sync
OFF	OFF	NAC will activate when Input #1 activates.	N/A	NAC will activate when Input #1 activates.	N/A
ON	OFF	NAC will activate when input #2 activates. (Exception: this Input controls Horn silencing during Selective Silence operation.)	NAC will activate when Input #2 activates provided the sync signal is present at Input #1.	NAC will activate when input #2 activates. (Exception: this Input controls Horn silencing during Selective Silence operation.)	NAC will activate when Input #2 is active regardless of sync input at Input #1. If Sync signal is present at Input #1, the output follows the sync. If the sync signal at Input #1 is deemed LOST, the outputs will turn on steady.
OFF	ON	NAC will activate when Input #3 activates (<i>Input #3 is only available on the 10 amp power supply model. If selected on 6 amp power supply, this setting will default to input #2.</i>)	NAC will activate when Input #3 activates, provided the sync signal is present at Input #1 (<i>Input #3 is only available on the 10 amp power supply model. If selected on 6 amp power supply, this setting will default to input #2.</i>)	NAC will activate when Input #3 activates (<i>Input #3 is only available on the 10 amp power supply model. If selected on 6 amp power supply, this setting will default to input #2.</i>)	NAC will activate when Input #3 is active regardless of sync input at Input #1. If Sync signal is present at Input #1, the output follows the sync. If the sync signal at Input #1 is deemed LOST, the outputs will turn on steady.
ON	ON	NAC will activate when any input (1, 2, or 3) activates.	NAC will activate when input #2 or input #3 activate provided sync signal is present at Input #1.	NAC will activate when any input (1, 2, or 3) activates.	NAC will activate when Input #2 OR Input #3 is active regardless of sync input at Input #1. If Sync signal is present at Input #1, the output follows the sync. If the sync signal at Input #1 is deemed LOST, the outputs are turned on steady.

Table 3.10 Output to Command Input Assignment

See Section 5 for an explanation of trouble reporting for each mode of operation.

Unused Outputs

The factory default setting for all output circuits is “unused/unsupervised” where positions 3, 4, 5, and 6 are set to the OFF position. Any unused or disabled outputs in the system configuration must be set to OFF as shown below.

Position 3	Position 4	Position 5	Position 6	Auxiliary Power Type
OFF	OFF	OFF	OFF	Unused/Unsupervised. Outputs will not activate. <i>Factory default setting.</i>
ON	OFF	OFF	OFF	Reserved- Outputs will not activate

Table 3.11 Auxiliary Power Settings

Remote Supply with Resettable and Non-resettable Power

Each output circuit on the power supply can be used as a remote stand-alone power supply to provide power to any devices that require filtered, resettable or non-resettable power. The power supply can provide up to 3 amps of continuous current. Non-resettable power is suitable for powering annunciators and other peripheral equipment. Resettable power is suitable for four-wire smoke detectors. Resettable outputs reset when the mapped input receives a negative pulse trigger signal from FACP or control module. There will be a three second delay prior to output reset. The output reset will last 10 seconds. Set DIP switches positions indicated in Table 3.12 below to select auxiliary power type.

Position 3	Position 4	Position 5	Position 6	Auxiliary Power Type
OFF	ON	OFF	OFF	Non-resettable (constant) aux power
OFF	OFF	ON	OFF	Resettable aux power

Table 3.12 Auxiliary Power Settings

Door Holder

Each output circuit can be configured as a door holder circuit. Setting DIP switch positions according to Table 3.13 will configure the selected output circuit as a door holder circuit which will provide a steady 24 VDC to door holders until a mapped input activates an alarm or when an AC fail condition removes the power following a programmable delay. See “AC Loss Door Holder Dropout Timer” on page 25 for more information.

Position 3	Position 4	Position 5	Position 6	Door Holder
ON	ON	OFF	OFF	Set as door holder circuit

Table 3.13 Door Holder Power

Synchronizing NACs - Master/Slave Configurations

Each of the power supply outputs can be independently configured for Master or Slave Synchronization by setting DIP switches according to Table 3.14. Synchronization is a feature that controls the activation of notification appliances in such a way that all devices will turn on and off at exactly the same time. This is particularly critical when activating strobes which must be synchronized to avoid random activation and a potential hazard or confusion.

In some installations, it is necessary to synchronize the flash timing of all strobes in the system for ADA compliance. Strobes accomplish this by monitoring very short timing pulses on the NAC power which are created by an FACP with synchronization capability. If a NAC wire run from the host FACP or power supply is re-purposed as a control circuit to the input of a power supply, the power supply NAC output circuits can track (follow) the strobe synchronization timing pulses. This maintains the overall system flash timing of the additional strobes attached to this power supply. Note that strobe synchronization works only with non-coded NACs.

When the output circuit is configured as a *sync generator* (Master Synchronization Configuration), the sync input circuit will only be used to trigger the output. The power supply is the originator of the strobe synchronization pulse on the NAC output. Refer to Table 3.14 to select the desired Master Configuration sync type.

When the output circuit is configured as a *sync follower* (Slave Synchronization Configuration), the power supply’s NAC outputs track the strobe synchronization pulses present at the supply’s Input terminals (based on the settings selected from Table 3.10). The pulses originate from an upstream FACP or other power supply. Some FACPs provide synchronization timing pulses from a dedicated sync output connector. Connect the power supply input terminals to the FACP sync output connector instead of the FACP NAC.

If circuits are configured for both Master and Slave Configuration, devices must be installed in different zones or field of view on a circuit basis.

Position 3	Position 4	Position 5	Position 6	Synchronization Type
ON	OFF	ON	OFF	Slave Configuration (NAC follower) - NAC outputs track Command Input Circuits
OFF	ON	ON	OFF	Master Configuration - ANSI Temporal (Temporal 3)
ON	ON	ON	OFF	Master Configuration - CO Temporal (Temporal 4)
OFF	OFF	OFF	ON	Master Configuration - Amseco/Potter
OFF	ON	OFF	ON	Master Configuration - Gentex
OFF	OFF	ON	ON	Master Configuration - System Sensor
OFF	ON	ON	ON	Master Configuration - Wheelock

Table 3.14 Input#1 Sync Configuration - Master/Slave Configuration Settings

Master Configuration - Selective Silence

Selective Silence allows the silencing of the sounder portion of a horn/strobe combination device without turning off the strobe. Selective Silence is only supported while in Master Configuration setting for Amseco, Gentex, System Sensor, and Wheelock. Refer to Table 3.15 to select the desired Master Configuration, Selective Silence sync type.



NOTE: Do not apply synchronization signals to Command Input #1 and 2. Only trigger signals are allowed (i.e. constant 9-32 VDC). Synchronization signal is internally generated by the system when in Master Configuration.

Only Command Inputs #1 and #2 are used to control the Selective Silence operation. (Command Input #3 on 10 amp power supply does not support Selective Silence.) Input #1 is for activating the horn/strobe devices, while Input 2 only controls sounding of the horns. Input #1 must be active for Input #2 to have any effect on NAC outputs set for Selective Silence. The list below provides additional detail.

- If only Command Input #1 is active, only the strobes will be activated .
- If both Command Input #1 and #2 are active, strobes and horns will be activated.
- If only Command Input #2 is active, NAC outputs will not be activated.
- If neither Command Input #1 nor #2 is active, NAC outputs will not be activated.

Position 3	Position 4	Position 5	Position 6	Synchronization Type
ON	OFF	OFF	ON	Master Configuration, Selective Silence - Amseco/Potter
ON	ON	OFF	ON	Master Configuration, Selective Silence - Gentex
ON	OFF	ON	ON	Master Configuration, Selective Silence - System Sensor
ON	ON	ON	ON	Master Configuration, Selective Silence - Wheelock

Table 3.15 Master Configuration - Selective Silence Settings

Class A Wiring

NAC circuits (all outputs) and aux power circuits (outputs 1 and 2) can be converted to Class A wiring using the ZNAC-PS option card. Setting DIP switch position 7=ON when a selected output circuit is configured for Class A wiring. The default setting is OFF for Class B wiring.

■ Maximum Number of Strobes for Synchronization

The total current draw for each Notification Appliance Circuit cannot exceed 3.0 amps special application, 1A (6 amp model) or 1.5A (10 amp model) regulated. Refer to the manufacturer's documentation supplied with the strobe to determine the maximum current draw for each strobe and ensure that the circuit maximum is not exceeded.

To ensure proper strobe and circuit operation, there is also a limit to the number of strobes that can be attached to each circuit. Following is a table of the strobes that have been tested with the power supply and the maximum number that can be connected to each NAC when using the lowest candela settings. *Make sure that the NAC maximum current is not exceeded:*

Manufacturer	max. number of strobes ¹
System Sensor	69
Gentex	42
Wheelock	50
Amseco/Potter	34

Table 3.16 Maximum Number of Strobes

¹ These values are for strobe-only devices at the minimum candela setting. Values will be different for strobe/horn and horn-only devices. Refer to the manufacturer's installation documents for values on these devices.

Section 4: LED Indicators

The power supply has 3 system LED indicators for Power, Batt/Chgr Fault, and Ground Fault. In addition, each available output circuit also has 2 status LEDs. Refer to Figure 1.1 on page 10 for LED locations. A description of each LED indication is given below.

Ground Fault LED (yellow)

No Fault

LED is OFF



Fault Condition:
ground fault

LED is ON constant



Power LED (green)

No Fault

LED is ON constant



Fault Condition:
AC power loss (or brownout)
1 short blink (250ms)

Repeating LED blink pattern (non-diagnostic phase and diagnostic phase)

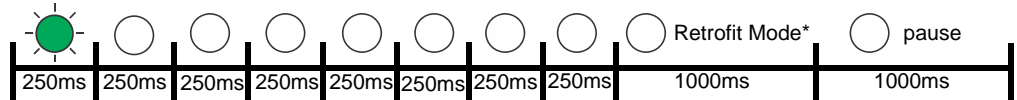

*Retrofit Mode will be indicated by an LED blink on the NAC1 Trouble LED only.

Battery fault LED (yellow)

No Fault

LED is OFF



Fault Condition:
Charging path (FETs) failure
1 short blink (250ms)

Repeating LED blink pattern (non-diagnostic phase and diagnostic phase)

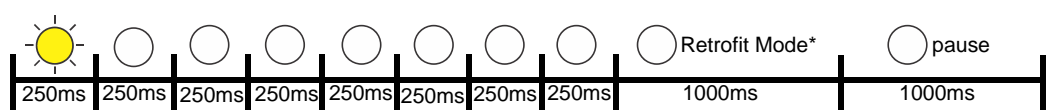

Fault Condition:
Charger voltage too low or
Charger Diode Fault
2 short blinks (250ms)

Repeating LED blink pattern (non-diagnostic phase and diagnostic phase)

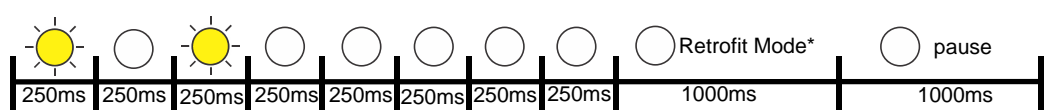

Fault Condition:
Battery
discharged/overcharged
3 short blinks (250ms)

Repeating LED blink pattern (non-diagnostic phase and diagnostic phase)

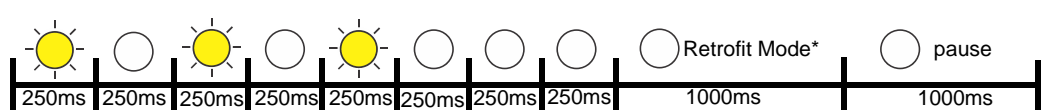

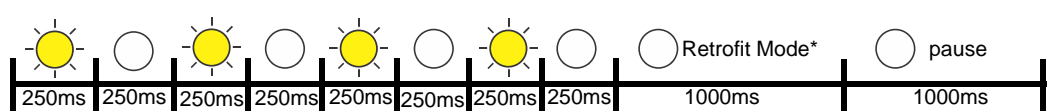

Fault Condition:
Battery disconnected/fully
discharged
4 short blinks (250ms)

Repeating LED blink pattern (non-diagnostic phase and diagnostic phase)





*Retrofit Mode will be indicated by an LED blink on the NAC1 Trouble LED only.

Output Circuit Status LEDs (red)

Output inactive	LED is OFF 
Output active	LED is ON constant 

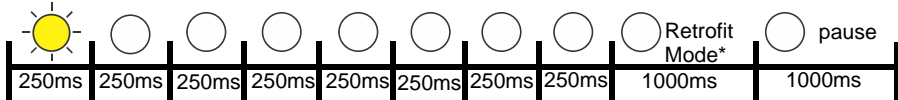
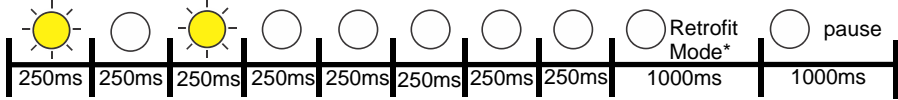
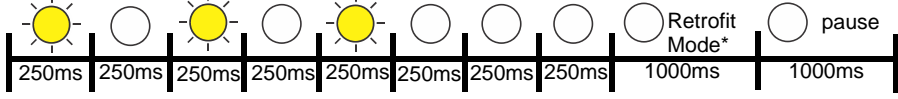
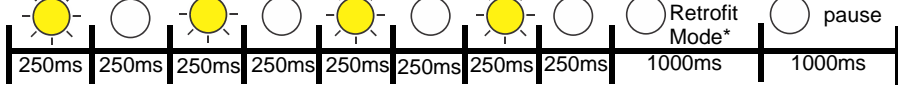
Output Circuit Trouble LEDs (yellow)

No Fault	LED is OFF 
Fault Condition: Wire Supervision Class A or B Open circuit 1 short blink (250ms)	Repeating LED blink pattern (non-diagnostic phase and diagnostic phase) 
	*Retrofit Mode will be indicated by an LED blink on the NAC1 Trouble LED only
Fault Condition: Wire Supervision Class A or B Short Circuit 2 short blinks (250ms)	Repeating LED blink pattern (non-diagnostic phase and diagnostic phase) 
	*Retrofit Mode will be indicated by an LED blink on the NAC1 Trouble LED only
Fault Condition: Aux Power Supervision Class A Open circuit (ZNAC-PS Circuit #1 and #2 only) 3 short blinks (250ms)	Repeating LED blink pattern (non-diagnostic phase and diagnostic phase) 
	*Retrofit Mode will be indicated by an LED blink on the NAC1 Trouble LED only
Fault Condition: Power limit condition (individual ckt overload) 4 short blinks per individual circuit (250ms)	Repeating LED blink pattern (non-diagnostic phase and diagnostic phase) 
Fault Condition: Power limit condition (panel overload) 4 short blinks on all output circuits (250ms)	Repeating LED blink pattern (non-diagnostic phase and diagnostic phase) 
	*Retrofit Mode will be indicated by an LED blink on the NAC1 Trouble LED only
Operating Mode Fault: Power Supply Change Output Config. Mode Set positions 9 and 10 on S1 to the correct position. Refer to "Operating Modes" on page 26.	Repeating LED blink pattern (non-diagnostic phase) Output circuit Trouble LEDs blink from right to left across all output circuits for 500ms.

Retrofit Mode Indication (yellow)

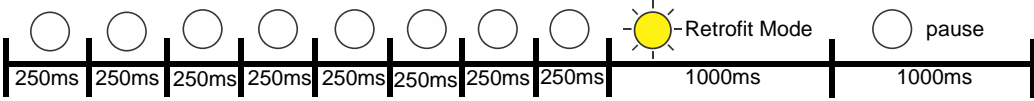
Retrofit Mode will be indicated by an LED blink on the NAC1 Trouble LED only. NAC outputs fault conditions will still be indicated by short 250ms blinks (where applicable).	Repeating LED blink pattern (non-diagnostic phase and diagnostic phase) 
--	---

Section 5: Trouble Supervision

The FACP will detect power supply faults. Any of the following conditions will cause the trouble contact to open, provided the FACP Notification Appliance Circuit is *not* in alarm.

5.1 Trouble Supervision Using Input Circuits

The FACP (Fire Alarm Control Panel) supervises the connection between itself and the power supply via the control panel's NAC End-of-Line Resistor (ELR). To supervise the power supply, an ELR must be installed across terminals 1 & 4 (A+ & A-) of Command Inputs #1 and #2 (and #3 for the 10 amp models). A field wiring fault on the NAC output of the power supply will trigger a disconnection of the ELR at the related Command Input, causing a general NAC trouble at the FACP provided the FACP's NAC is *not* in alarm. All inputs in an alarm state will close their EOL relays to allow the daisy-chaining of input signals (both in Default Mode or Retrofit Mode). Refer to Section 3.2, "Output Circuit Control DIP Switch Settings", on page 27 for input/output configuration assignment. The following are exceptions.

1. Resettable Aux Power, Non-Resettable Aux Power, and Door Holder Aux Power outputs will trigger the General Trouble relay only during an output trouble regardless of the output to input relationship (i.e. mapping) when the Power supply is configured in the Default Mode. When configured in Retrofit Mode, they will be reported by either the Input#1 or Input#2 (if Input #1 is in Sync Configuration) EOL relay, and in addition by the General Trouble relay Refer to 5.2, "General Trouble Relay" below.
2. Faults are only reported by Command Input #1 when Selective Silence Output Configuration is controlled by Command Input #1 and #2.
3. Faults are only reported by the trigger input when Command Input #1 is configured for Sync Configuration operation controlled by a sync and trigger input.

If the power supply is in alarm, only a power-limiting condition on the NAC will be detected as a trouble.

If other trouble monitoring is required when the power supply is in alarm, the Trouble Relay at TB1 and AC Trouble at TB2, and Ground Fault Trouble at TB3 can be used for this purpose.

The following table summarizes the trouble supervision using the input end-of-line relays in both Default Mode and Retrofit Mode.

Note that when the power supply is configured for Retrofit Mode, the FACP should be monitoring either Input #1/Input #2 end-of-line relay or the General trouble relay, not both.

Panel Status	Default Mode	Retrofit Mode
Input #x end-of-line relays in standby	<ul style="list-style-type: none"> • Any new open, short, ZNAC faults, or existing power-limiting conditions of Slave or Master (non-selective silence) NAC outputs are reported at the mapped command input EOL relay (or Input #1 in case of outputs mapped to ALL inputs). • If Input #1 is configured as a sync input, outputs can be mapped only to trigger Inputs #2 or Input #3 or either. If there is a trouble on any output circuits, the Input #1 EOL relay is unaffected. Any new open, short, ZNAC faults, or existing power-limiting conditions of Slave or Master (non-selective silence) NAC outputs are, however, reported at respective mapped Command Input #2 or Input #3 EOL Relay or at Command Input #2 if outputs are mapped to either. • Any new open, short, ZNAC faults, or existing power-limiting conditions of Master selective silence NAC outputs are reported at the Input #1 EOL relay. 	<p>If Input #1 is configured as Normal (S1 DIP switch 3 =ON):</p> <ul style="list-style-type: none"> • Any new open, short, ZNAC faults, or existing power-limiting conditions of Slave or Master (non-selective silence) NAC outputs are reported at the Input #1 EOL relay (for any outputs mapped to either Input #1, Input #2, Input #3, or mapped to ALL inputs) • Any new open, short, ZNAC faults, or existing power-limiting conditions of Master selective silence NAC outputs are reported at the Input #1 EOL relay. • Any new or existing fault conditions of resettable aux power, non-resettable aux power, or door holder outputs are reported at the Input #1 EOL relay. • Any new or existing battery, charger, panel overload, or AC fuse trouble conditions are reported at the Input #1 EOL relay. <p>If S1 Global DIP switch 8 = OFF</p> <ul style="list-style-type: none"> • Any new or existing AC trouble or ground fault trouble are reported at Input #1 EOL Relay (with 0 or 2h AC trouble delay depending on S1 Global DIP switch 7 Configuration). <p>If S1 Global DIP switch 8=ON</p> <ul style="list-style-type: none"> • Any new or existing ground fault trouble will be reported at Input #1 EOL Relay. <p>If Input #1 is configured as Sync (S1 DIP switch 3 =OFF):</p> <ul style="list-style-type: none"> • Any new open, short, ZNAC faults, or existing power-limiting conditions of Slave or Master (non-selective silence) NAC outputs are reported at the Input #2 EOL relay (for any outputs mapped to either Input #2, Input #3, or mapped to ALL inputs). • Any new or existing fault conditions of resettable aux power, non-resettable aux power, or door holder outputs are reported at the Input #2 EOL relay. • Any new or existing battery, charger, panel overload, or AC fuse trouble conditions are reported at the Input #2 EOL relay. <p>If S1 Global DIP switch 8 = OFF</p> <ul style="list-style-type: none"> • Any new or existing AC trouble or ground fault trouble are reported at Input #2 EOL Relay (with 0 or 2h AC trouble delay depending on S1 Global DIP switch 7 Configuration) <p>If S1 Global DIP switch 8=ON</p> <ul style="list-style-type: none"> • Any new or existing ground fault troubles will be reported at Input #2 EOL Relay.
Input #x end-of-line relays in alarm	<ul style="list-style-type: none"> • All inputs in alarm state will close their EOL relays to allow the daisy-chaining of input signals. 	<ul style="list-style-type: none"> • All inputs in alarm state will close their EOL relays to allow the daisy-chaining of input signals

Table 5.1 Operating Mode Behavior for Trouble Supervision Using Input Circuits

5.2 General Trouble Relay

The power supply has a fail-safe Form-C trouble relay located at TB1. The contacts can be monitored by an FACP input circuit or an addressable monitor module as illustrated in Figure 5.1. Note that any faults reported by Command Inputs are not repeated by the trouble relay in Default Mode, offering limited trouble reporting. For Retrofit Mode trouble reporting, refer to Table 5.1 above and Table 5.2 below. When the power supply is configured for Retrofit Mode, the FACP should be monitoring either Input #1/Input #2 end-of-line relay or the General Trouble Relay, but not both.

Trouble conditions that will cause the normally energized trouble relay to change states regardless of whether the panel is in alarm or standby:

- A battery fail condition at the power supply
- A battery charger fail on the power supply
- A ground fault condition on the power supply (in Retrofit Mode if S1 Global DIP switch 8 = OFF)
- An AC fail condition (only in Retrofit Mode, if S1 Global DIP switch 8 = OFF)
- A field wiring fault on the power supply outputs configured as resettable aux power, non-resettable aux power, or door holder aux power
- A total panel overload fault
- A blown AC fuse
- A field wiring fault on the NAC output configured as Slave, Master, or Master Selective Silence Outputs (only in Retrofit Mode)

The following table summarizes the trouble supervision using the General trouble relay in both Default Mode and Retrofit Mode.

Note that when the power supply is configured in Retrofit Mode, the FACP should be monitoring either Input #1/Input #2 end-of-line relay or the Internal trouble relay, but not both.

Panel Status	Default Mode	Retrofit Mode
General Trouble relay in Standby and Alarm	<ul style="list-style-type: none"> • Any new or existing battery, charger, panel overload, AC fuse, or ground trouble conditions are reported. • Any new or existing fault conditions of resettable aux power, non-resettable aux power, or door holder outputs are reported. 	<ul style="list-style-type: none"> • Any new or existing battery, charger, panel overload, or AC fuse trouble conditions are reported. • Any new or existing fault conditions of resettable aux power, non-resettable aux power, or door holder outputs are reported. • Any new open, short, ZNAC faults, or power-limiting conditions of Slave or Master (non-selective silence) NAC outputs which are mapped to command Input 1, Input 2, Input 3, or mapped to ALL inputs are reported. • Any new open, short, ZNAC faults, or existing power-limiting conditions of Master selective silence NAC outputs are reported. <p>If S1 Global DIP switch 8= OFF</p> <ul style="list-style-type: none"> • Any new or existing AC trouble or ground fault trouble are reported (with 0 or 2h AC trouble delay depending on S1 Global DIP switch 7 Configuration). <p>If S1 Global DIP switch 8=ON</p> <ul style="list-style-type: none"> • Any new or existing ground fault trouble will be reported.

Table 5.2 Operating Mode Behavior for the General Trouble Relay

If trouble monitoring is required when the power supply is in alarm, the General Trouble Relay at TB1 can be used for this purpose. Refer to Figure 5.1 below.



NOTE: The individual NAC Trouble LED will indicate which NAC circuit is in trouble.

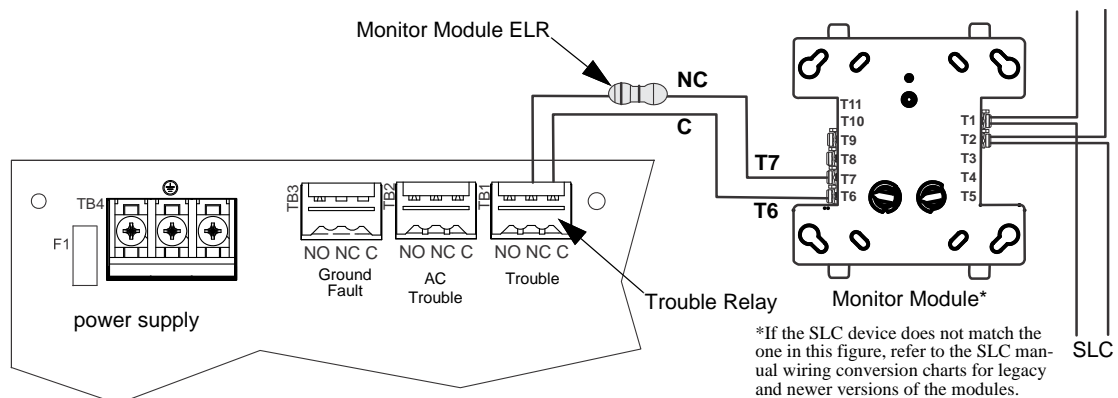

Figure 5.1 Monitoring the Trouble Relay

Figure 5.2 illustrates how to wire for trouble monitoring in US applications where separate ground fault monitoring is not required.

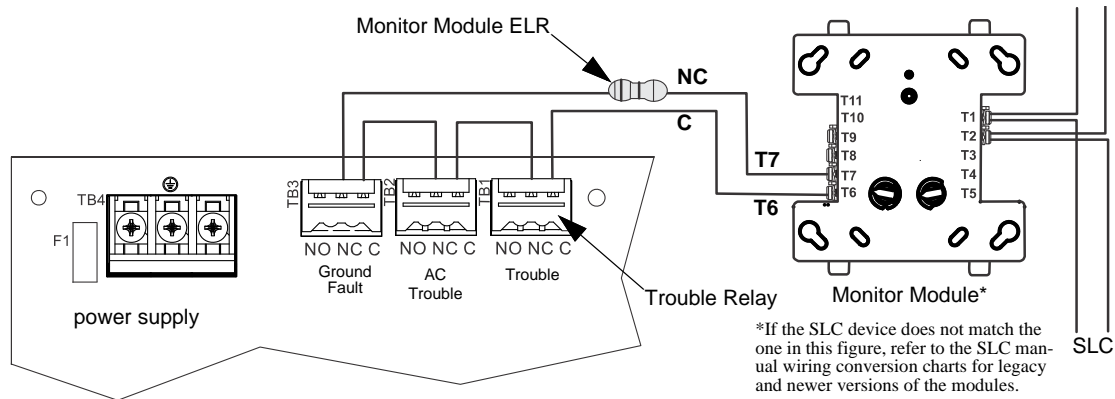

Figure 5.2 Monitoring the Trouble Relay (US Applications)

5.3 AC Trouble Relay

The power supply has a fail-safe Form-C trouble relay located at TB2. The contacts can be monitored by an FACP input circuit or an addressable monitor module similar to the drawing illustrated in Figure 5.1. The AC Trouble Relay responds to an AC fail condition on the power supply immediately, or after a programmed delay time, depending on the setting of S1 switches 7 and 8.

The reporting of AC loss to a central station is usually delayed in order to prevent multiple transmissions of AC loss and restoral, allowing AC power to stabilize. When a host FACP is programmed to delay AC loss reporting, the power supply must be configured to delay the reporting of AC fail. This is accomplished by setting S1 positions 7 and 8. Refer to the DIP switch setting chart in Table 3.5 on page 26. This will prevent AC loss from being reported as a trouble condition for 30, 12, 2, or 0 hours. (Only the 2 and 0 hours options are available in Retrofit Mode.) Note that only no delay and the 2 hour delay are acceptable per UL 864 and UL 2572.

Note that when the power supply is configured for Retrofit Mode, the S1 Global DIP switch 8 setting will determine how an AC power loss trouble condition is reported

- If S1 Global DIP switch 8 = OFF, an AC power loss trouble condition is reported by either Input #1 or Input #2 EOL relay and by the General Trouble relay.
- If S1 Global DIP switch 8 = ON, an AC power loss trouble condition is reported by the AC trouble relay only.

The following table summarizes the trouble supervision using the AC trouble relay in both Default Mode and Retrofit Mode.

Panel Status	Default Mode	Retrofit Mode
AC Trouble relay in Standby and Alarm	<ul style="list-style-type: none"> • Any new or existing AC trouble conditions are reported (with 0, 2, 12, or 30 hour delay depending on S1 Global DIP switch 7 and 8 configuration). 	<ul style="list-style-type: none"> • IF S1 Global DIP switch 8 = ON, any new or existing AC trouble conditions are reported (with 0 or 2 hour delay depending on S1 Global DIP switch 7 configuration.)

5.4 Ground Fault Relay

The power supply has a form-C trouble relay located at TB3. The contacts can be monitored by an FACP input circuit or an addressable monitor module similar to the drawing illustrated in Figure 5.1. Ground fault conditions will cause the relay to change states regardless of whether the panel is in alarm or standby.

Note that when the power supply is configured for Retrofit Mode, the S1 Global DIP switch 8 setting will determine how a Ground fault trouble condition is reported.

- S1 Global DIP switch 8 = OFF, a ground fault trouble condition is reported by either Input #1 or Input #2 EOL relay, and by the General Trouble relay.
- S1 Global DIP switch 8 = ON, a ground fault trouble condition is reported by the Ground fault relay only.

The following table summarizes the trouble supervision using the Ground fault relay in both Default Mode and Retrofit Mode.

Panel Status	Default Mode	Retrofit Mode
Ground Fault relay in Standby and Alarm	<ul style="list-style-type: none"> • Any new or existing ground fault trouble conditions are reported (for Canadian applications only). 	<ul style="list-style-type: none"> • S1 Global DIP switch 8 = ON, any new or existing ground fault trouble conditions are reported.

Section 6: Power Supply Requirements

6.1 Overview

This section contains instructions and tables for calculating power supply currents in alarm and standby conditions. This is a four-step process, consisting of the following:

1. Calculating the total amount of AC branch circuit current required to operate the system
2. Calculating the power supply load current for secondary non-fire and fire alarm conditions
3. Calculating the size of batteries required to support the system if an AC power loss occurs
4. Selecting the proper batteries for your system

6.2 Calculating the AC Branch Circuit

The power supply requires connection to a separate, dedicated AC branch circuit, which must be labeled **FIRE ALARM**. This branch circuit must connect to the line side of the main power feed of the protected premises. No other non-fire alarm equipment may be powered from the fire alarm branch circuit. The branch circuit wire must run continuously, without any disconnect devices, from the power source to the power supply. Overcurrent protection for this circuit must comply with Article 760 of the National Electrical Codes as well as local codes. Use a minimum of 14 AWG (2.00 mm²) wire with 600 volt insulation for this branch circuit.

Use Table 6.1 to determine the total amount of current, in AC amperes, that must be supplied to the system.

Device Type	Number of Devices		Current Draw (AC amps)		Total Current per Device
120V, 6 amp model or 120V, 10 amp model or 240V, 6 amp model or 240V, 10 amp model	1	x	5.0 or 6.2 or 2.7 or 3.5	=	
[]	[]	x	[]	=	
[]	[]	x	[]	=	
Sum Column for AC Branch Current Required				=	

Table 6.1 120/240 VAC Branch Circuit Requirements

6.3 Calculating the System Current Draw

6.3.1 Overview

The power supply must be able to power all internal and external devices continuously during a fire alarm condition. The secondary power source (batteries) must be able to power the system during a primary power loss. To calculate the non-fire alarm load on the power supply when secondary power is applied, use Calculation Column 1 in Table 6.3 on page 37. The power supply must support a larger load current during a fire alarm condition. To calculate the fire alarm load on the power supply as secondary power, use Calculation Column 2 in Table 6.3 on page 37.

When calculating current draw and the battery size, note the following:

- *Primary* refers to the main power source for the power supply.
- *Secondary* refers to the power supply's backup batteries.
- All currents are given in amperes (A). Table 6.2 shows how to convert milliamperes and microamperes to full amperes.

To convert...	Multiply	Example
Milliamperes (mA) to amperes (A)	mA x 0.001	3 mA x 0.001 = 0.003 A
Microamperes (μA) to amperes (A)	μA x 0.000001	300 μA x 0.000001 = 0.0003 A

Table 6.2 Converting to Full Amperes

6.3.2 How to Calculate System Current Draw

Use Table 6.3 to calculate current draws as follows and refer to the battery calculation tool on the fire panel brand’s website.

1. Enter the quantity of devices in both columns.
2. Enter the current draw where required. Refer to the *Device Compatibility Document* for the brand of FACP for compatible devices and their current draws.
3. Calculate the current draws for each in both columns.
4. Sum the total current for each column.

Following are the types of current that can be entered into Table 6.3.

- ✓ **Calculation Column 1** - The secondary supply current load that the power supply must support during a non-fire alarm condition, with DC power applied
- ✓ **Calculation Column 2** - The secondary supply current load the power supply must support during a fire alarm condition, with DC power applied

Table 6.3 contains two columns for calculating current draws. For each column, calculate the current and enter the total (in amperes) in the bottom row. When finished, use the data to select the proper size batteries in Tables 6.4 and 6.5.

Device Type	Calculation Column 1 Secondary, Non-Fire Alarm Current (amps)			Calculation Column 2 Secondary, Fire Alarm Current (amps)		
	Qty	X (current draw) =	Total	Qty	X (current draw) =	Total
Main Circuit Board - 6 amp power supply with all outputs 2k EOL	1	X [0.154] =		1	X [0.192] =	
Main Circuit Board - 6 amp power supply with 4.7k EOL	1	X [0.139] =		1	X [0.157] =	
Main Circuit Board - 6 amp power supply with 27k EOL	1	X [0.124] =		1	X [0.137] =	
Main Circuit Board - 6 amp power supply with all Outputs Aux Power Class B	1	X [0.132] =		1	X [0.132] =	
Main Circuit Board - 6 amp power supply with ZNAC-PS Class A option card with all outputs Aux Power	1	X [0.142] =		1	X [0.142] =	
Main Circuit Board - 10 amp power supply with all outputs 2k EOL	1	X [0.178] =		1	X [0.232] =	
Main Circuit Board - 10 amp power supply with 4.7k EOL	1	X [0.156] =		1	X [0.185] =	
Main Circuit Board - 10 amp power supply with 27k EOL	1	X [0.135] =		1	X [0.154] =	
Main Circuit Board - 10 amp power supply with all Outputs Aux Power Class B	1	X [0.149] =		1	X [0.149] =	
Main Circuit Board - 10 amp power supply with ZNAC-PS Class A option card with all outputs Aux Power	1	X [0.160] =		1	X [0.160] =	
NAC/Output #1	[]	X [] =		[]	X [] =	
NAC/Output #2	[]	X [] =		[]	X [] =	
NAC/Output #3	[]	X [] =		[]	X [] =	
NAC/Output #4	[]	X [] =		[]	X [] =	
NAC/Output #5	[]	X [] =		[]	X [] =	
NAC/Output #6	[]	X [] =		[]	X [] =	
NAC/Output #7	[]	X [] =		[]	X [] =	
EOLR-1 Power Supervision Relay	[]	X [0.020] =		[]	X [0.020] =	
Sum each column for totals		Secondary Non-Alarm =		Secondary Alarm =		

Table 6.3 System Current Draw Calculations

6.4 Selecting and Locating Batteries

Select batteries that meet or exceed the total ampere hours determined in Tables 6.4 and 6.5. The power supply can charge batteries from 7 AH to 33 AH range. The power supply cabinet is capable of housing industry standard 7 AH or 18 AH batteries. Other ampere batteries (e.g. 12AH, 26AH, 33AH) will not fit physically inside the power supply cabinet and require a separate battery box.

6.4.1 NFPA Battery Requirements

NFPA 72 Local and Proprietary Fire Alarm Systems require 24 hours of standby power followed by 5 minutes in alarm for normal operations, 15 minutes for mass notification systems, or 30 minutes for Canadian applications.



NOTE: When using carbon monoxide detection, the system must be monitored by a Supervising Station meeting the Standard for the Installation of Carbon Monoxide (CO) Detection and Warning Equipment, NFPA 720.

6.4.2 Maximum Battery Standby Load

Tables 6.4 and 6.5 show the standby load calculations for the power supply based on 24 hours of standby. The standby load calculations in the Table 6.3 must be less than the number shown in Tables 6.4 and 6.5 for the selected battery size, standby hour and alarm time. The numbers below have a built in 20% derating factor for the battery ampere capacity.

Battery Capacity (AH)	Alarm Time (min)				
	5	10	15	20	30
7	0.212 A	0.190 A	0.169 A	0.147 A	N/A
12	0.379 A	0.357 A	0.336 A	0.314 A	0.271 A
18	0.579 A	0.557 A	0.536 A	0.514 A	0.471 A
33	1.079 A	1.057 A	1.036 A	1.014 A	0.971 A
75	2.479 A	2.457 A	2.436 A	2.414 A	2.371 A
120	3.000 A	3.000 A	3.000 A	3.000 A	3.000 A

Table 6.4 Maximum Battery Standby Loads for 24 Hour Standby on the 6 Amp Power Supply

Battery Capacity (AH)	Alarm Time (min)				
	5	10	15	20	30
7	0.198 A	0.162 A	N/A	N/A	N/A
12	0.364 A	0.329 A	0.293 A	0.258 A	0.187 A
18	0.564 A	0.529 A	0.493 A	0.458 A	0.387 A
33	1.064 A	1.029 A	0.993 A	0.958 A	0.887 A
75	2.464 A	2.429 A	2.393 A	2.358 A	2.287 A
120	3.000 A	3.000 A	3.000 A	3.000 A	3.000 A

Table 6.5 Maximum Battery Standby Loads for 24 Hour Standby on the 10 Amp Power Supply

Section 7: Testing and Maintenance

7.1 Periodic Testing and Service

Periodic testing and servicing of equipment is essential to ensure proper and reliable operation. Test and service the power supply according to the schedules and procedures outlined in the following documents:

- NFPA Standard 72's section on Inspection, Testing and Maintenance
- All test and maintenance instruction codes and software necessary to provide test and inspection requirements of CAN/ULC-S536, Standard for the Inspection and Testing of Fire Alarm Systems

7.2 Battery Checks and Maintenance

Maintenance-free sealed lead-acid batteries used in the system do not require the addition of water or electrolyte. These batteries are charged and maintained in a fully charged state by the main power supply's charger during normal system operation. A discharged battery typically reaches the voltage of 27.6 VDC within 48 hours;. Sealed lead-acid batteries must be replaced within at most 5 years from their date of manufacture. Minimal replacement battery capacity appears on the control panel marking label. Immediately replace a leaking or damaged battery. Replacement batteries are available from the manufacturer.



WARNING: SULFURIC ACID

BATTERIES CONTAIN SULFURIC ACID WHICH CAN CAUSE SEVERE BURNS TO THE SKIN AND EYES AND DAMAGE TO FABRICS.

F1 Fuse Replacement	Not Allowed
Rechargeable Battery Replacement	Recommended Part Numbers: <ul style="list-style-type: none">• BAT-1270 (12V,7AH)• BAT-12120 (12V, 12AH)• BAT-12180 (12V 18AH)• BAT-12260 (12V, 26AH)• BAT-12330 (12V, 33AH)

Appendix A: Wire Requirements

Connecting external system accessories to the main circuits must be carefully considered to ensure proper operation. It is important to use the correct type of wire, gauge and run length for each circuit. The following table lists NAC wiring requirements for the 6 amp and 10 amp Power Supply.

The numbers documented in this chart are worst case numbers, based on the conditions listed below. The maximum voltage drop, maximum loop resistance, and wire length ratings can be increased with lower system current loading. Measurements are in feet.

1. The power supply is full capacity loaded at 6A/10A.
2. The power supply is running at the Low Battery voltage of 20.4VDC (at Battery Connector TB15).

Wire lengths apply to Class B wiring, and to Class A wiring returned to the ZNAC-PS card.

Max Load (Amps)	Max Loop Resistance (Ohms)	AWG 12 (Solid)	AWG 14 (Solid)	AWG 16 (Solid)	AWG 18 (Solid)
0.25	12.804	3320	2087	1310	823
0.50	6.402	1660	1044	655	412
0.75	4.268	1107	696	437	274
1.00	3.201	830	522	327	206
1.25	2.561	664	417	262	165
1.50	2.134	553	348	218	137
1.75	1.829	474	298	187	118
2.00	1.601	415	261	164	103
2.25	1.423	369	232	146	91
2.50	1.280	332	209	131	82
2.75	1.164	302	190	119	75
3.00	1.067	277	174	109	69

Table A.1 Power Supply Wiring Requirements



NOTE: Calculations are based on Direct-Current Resistance data for uncoated copper wire, per National Electrical Code (2005 Edition) Table 8, Conductor Properties.



NOTE: These distances reflect the worst case scenario and are based on the correct draw of the highest candela strobes at the low end of the supported NAC voltage with the entire load at the end of the circuit. Further distances can be achieved by performing a point to point voltage calculation that more accurately reflects the specific devices used and how they are dispersed on the circuit.

Appendix B: Application Examples

B.1 Controlling NACs For Selective Silence Operation Using a Control Module

In this application, the power supply has been set as a master with synchronized outputs and selective silence (see DIP switch settings and Selective Silence Operation information in Section 3). This application requires Input #1 to be controlled by the FACP. Input #2 is required for controlling selective silence via a control/relay module, *programmed as an alarm output and a silenceable point*. Only *Mass Notification, Fire, or combo Mass Notification/Fire NACs are allowed in this configuration*. The control module can be powered by one of the power supply output circuits, configured as aux power (24VDC).

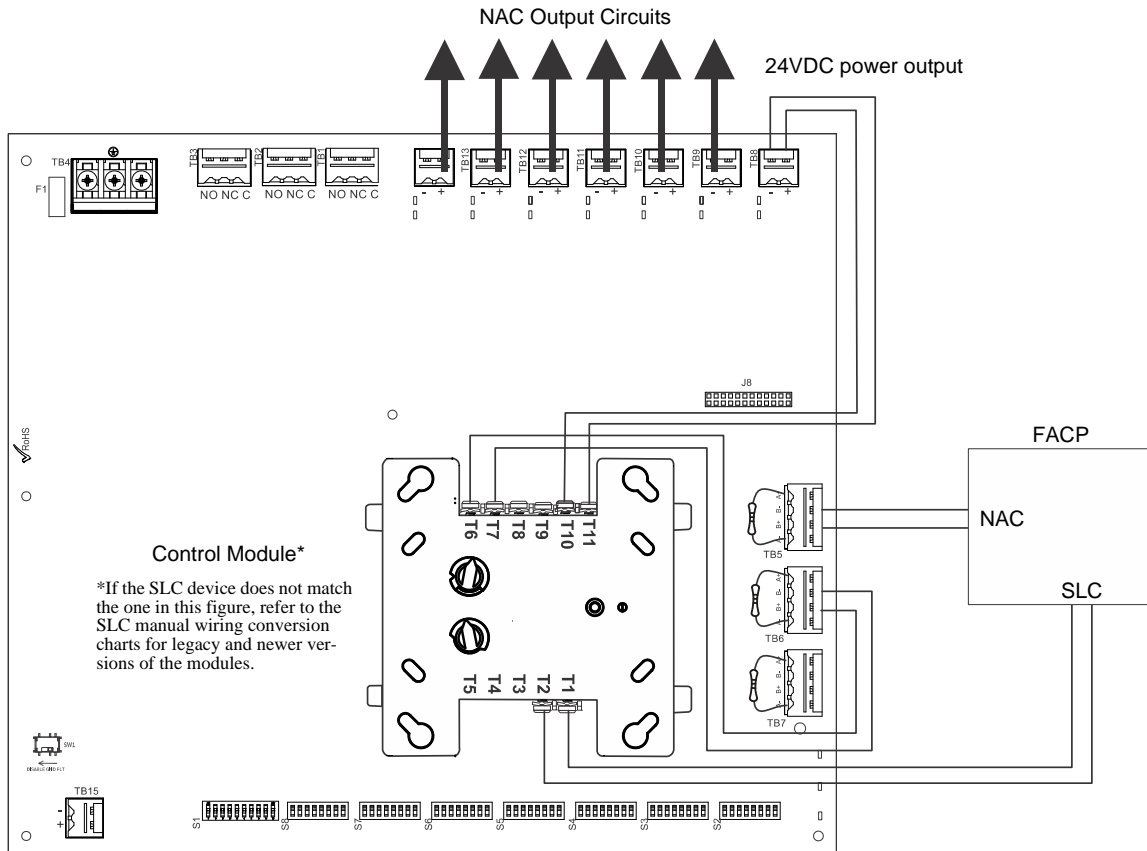

Figure B.1 Controlling Multiple Outputs with One Input

The following notes apply to Figure B.1.

When the power supply is in an inactive state (FACP NAC not active), a trouble on the NAC circuit will result in an open circuit condition on the FACP (monitored by End-of-Line Resistor across TB5, Terminals 1 and 4). As an alternative, the trouble contacts at TB1 of the power supply can also be used for limited trouble monitoring excluding Selective Silence output faults. Refer to Section 5 for more information.

- Refer to Section 3 for instructions on setting the DIP switches.
- Selective Silence output faults are only reported via Command Input #1 (not Command Input #2).
- Wire NACs as shown on page 13.
- Do not loop wires under screw terminals. Break wires to maintain proper supervision.
- An End-of-Line Resistor must be installed across all input circuits, Terminals 1 and 4, for control module wiring supervision (the ELR value is dependent on the module/FACP employed).
- For a list of compatible devices, refer to the *Device Compatibility Document* for the brand of FACP.
- Refer to the *SLC Wiring Manual* for more information.

B.2 Controlling NACs For Sync Follower Operation Using a Control Module (Default Mode Configuration Only)

In this application, the power supply has been set to operate in Slave Configuration and will follow the sync signal from the FACP. This application requires Input #1 to be controlled by the FACP sync output. Input #1 may be wired to the next power supply or terminate in and ELR. Input #2 (or Input #3, if available) will act as the trigger signal for the output circuits. The control module can be powered by one of the power supply output circuits, configured as aux power (24VDC). See Table 3.14 on page 29 for DIP switch settings.

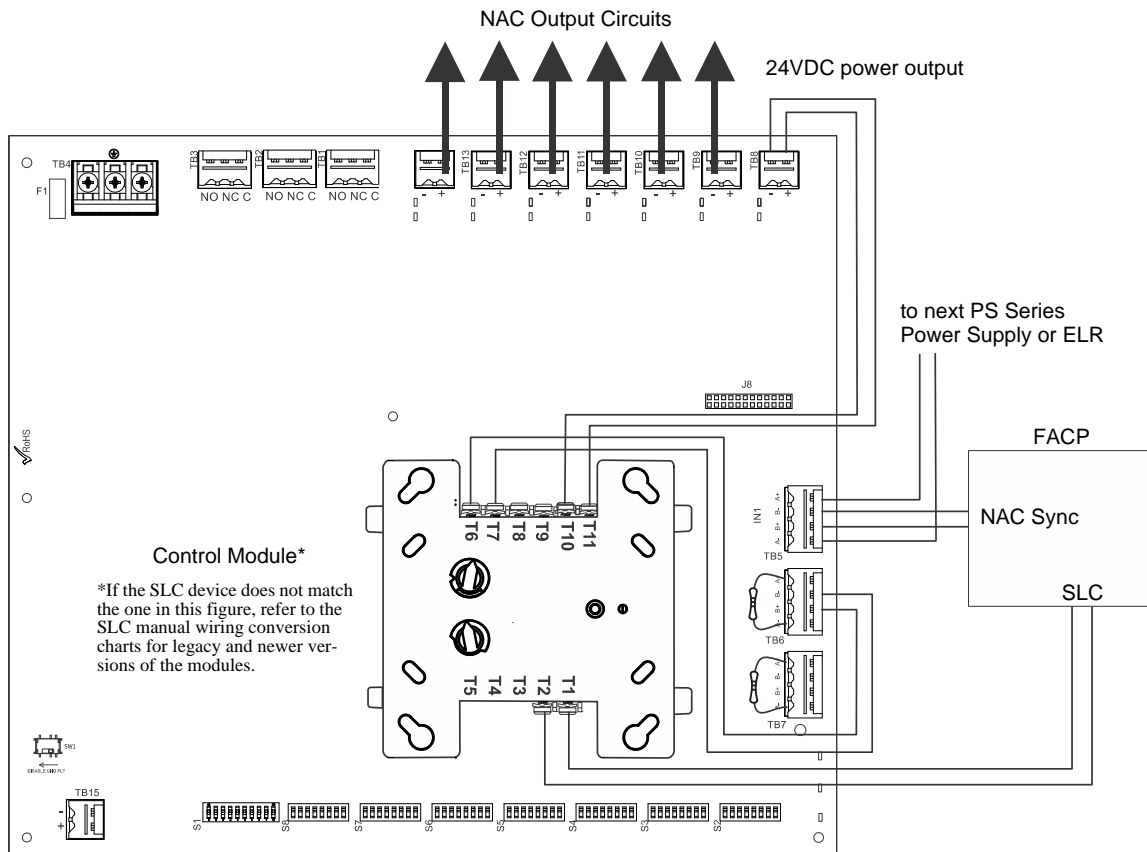

Figure B.2 Controlling Multiple Outputs with One Input as Sync Follower

The following notes apply to Figure B.2.

- When the power supply is in an inactive state (control module not active), a trouble on the NAC circuits mapped to TB6 will result in an open circuit condition on the control module output circuit (monitored by End-of-Line Resistor across TB6, Terminals 1 and 4). As an alternative, the trouble contacts at TB1 of the power supply can also be used for limited trouble monitoring excluding faults reported by Command Input #2 related to Command Input#1 configured for Sync Input Configuration. Refer to Section 5 for more information.
- Refer to Section 3 for instructions on setting the DIP switches.
- Output faults are reported via Command Input#2 with Command Input#1 configured for Sync Input Configuration operation.
- Refer to the FACP manual for load restrictions and line length limitations when wiring multiple power supplies at the input.
- Wire NACs as shown on page 13.
- Do not loop wires under screw terminals. Break wires to maintain proper supervision.
- An End-of-Line Resistor must be installed across all input circuits, Terminals 1 and 4, for control module wiring supervision (the ELR value is dependent on the module/FACP employed).
- For a list of compatible devices, refer to the *Device Compatibility Document* for the brand of FACP.
- Refer to the *SLC Wiring Manual* for more information.

B.3 Controlling NACs, Aux Power, or Door Holders Using a Control Module

All output circuits, NACs, aux power (non-resettable power – active regardless of control module state), or door holders, can be controlled from one input such as an addressable control module as illustrated in Figure B.3. The control module can be powered from one of the power supply output circuits, as 24 VDC power. In this example, Output #1 will be configured as 24VDC non-resettable aux power.

The control module is shown to demonstrate the use of an internally mounted device associated with an addressable fire alarm control panel. The module could be replaced with any circuit capable of polarity reversal, such as an FACP Notification Appliance Circuit.

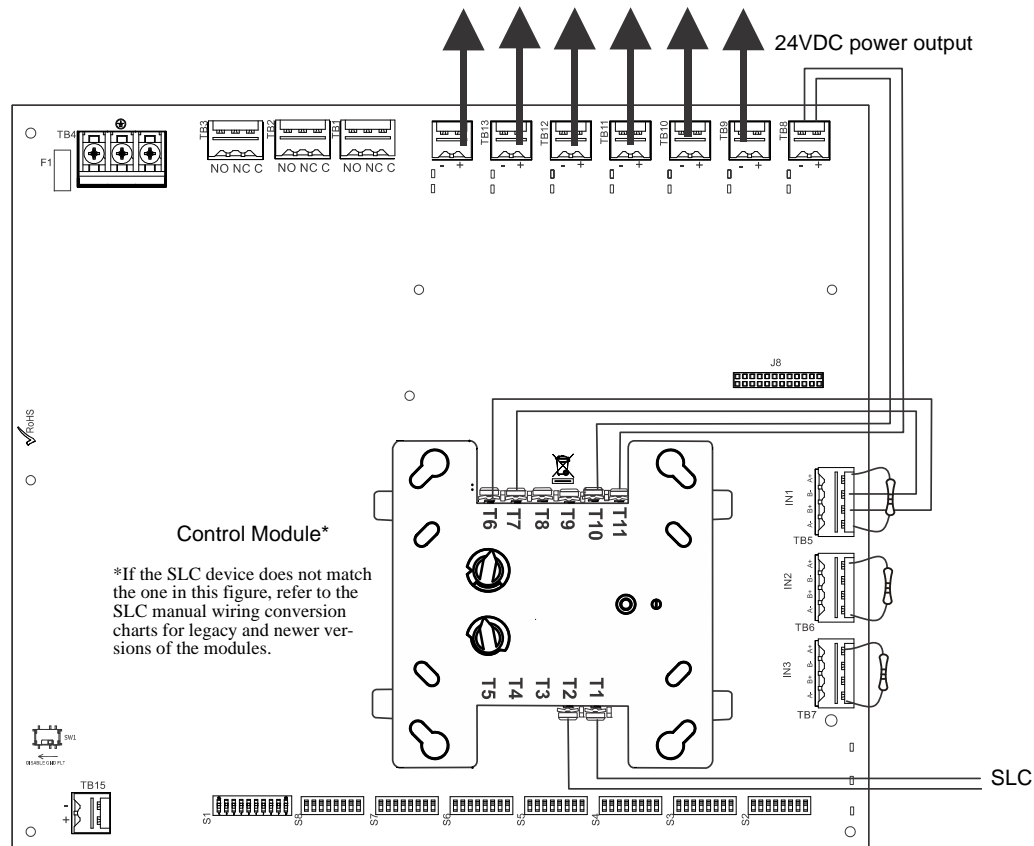

Figure B.3 Controlling NACs, Aux Power, and Door Holders with One Input

The following notes apply to Figure B.3.

- Any output circuit can be configured as NAC, door holder, or 24VDC power.
- Wire NACs as shown on page 13.
- Refer to Section 3 for instructions on setting the DIP switches.
- When the power supply is in an inactive state (control module not active), a trouble on the NAC circuits mapped to TB5 will result in an open circuit condition on the control module output circuit (monitored by an End-of-Line Resistor across Terminals 1 and 4). Additionally, the trouble contacts at TB1 of the power supply can also be used for limited trouble monitoring excluding output faults reporting to Command Input #1. Refer to Section 5 for more information.
- Do not loop wires under screw terminals. Break wires to maintain proper supervision.
- An End-of-Line Resistor must be installed between terminals 1 and 4 for control module wiring supervision (the ELR value is dependent on the module/FACP employed).
- For a list of compatible devices, refer to the *Device Compatibility Document* for the brand of FACP.
- Refer to the *SLC Wiring Manual* for more information.

B.4 Controlling NACs, Aux Power, and Door Holders with NAC Sync

In this application, use of a sole dual relay/monitor module mounted inside the cabinet can monitor the two power supply trouble relays and trigger two independent inputs via relay circuits. power supply outputs #1 and #2 are being used for 24 VDC aux power triggered by the module's relay circuits. Any power supply output circuit can be configured to follow any input circuit.

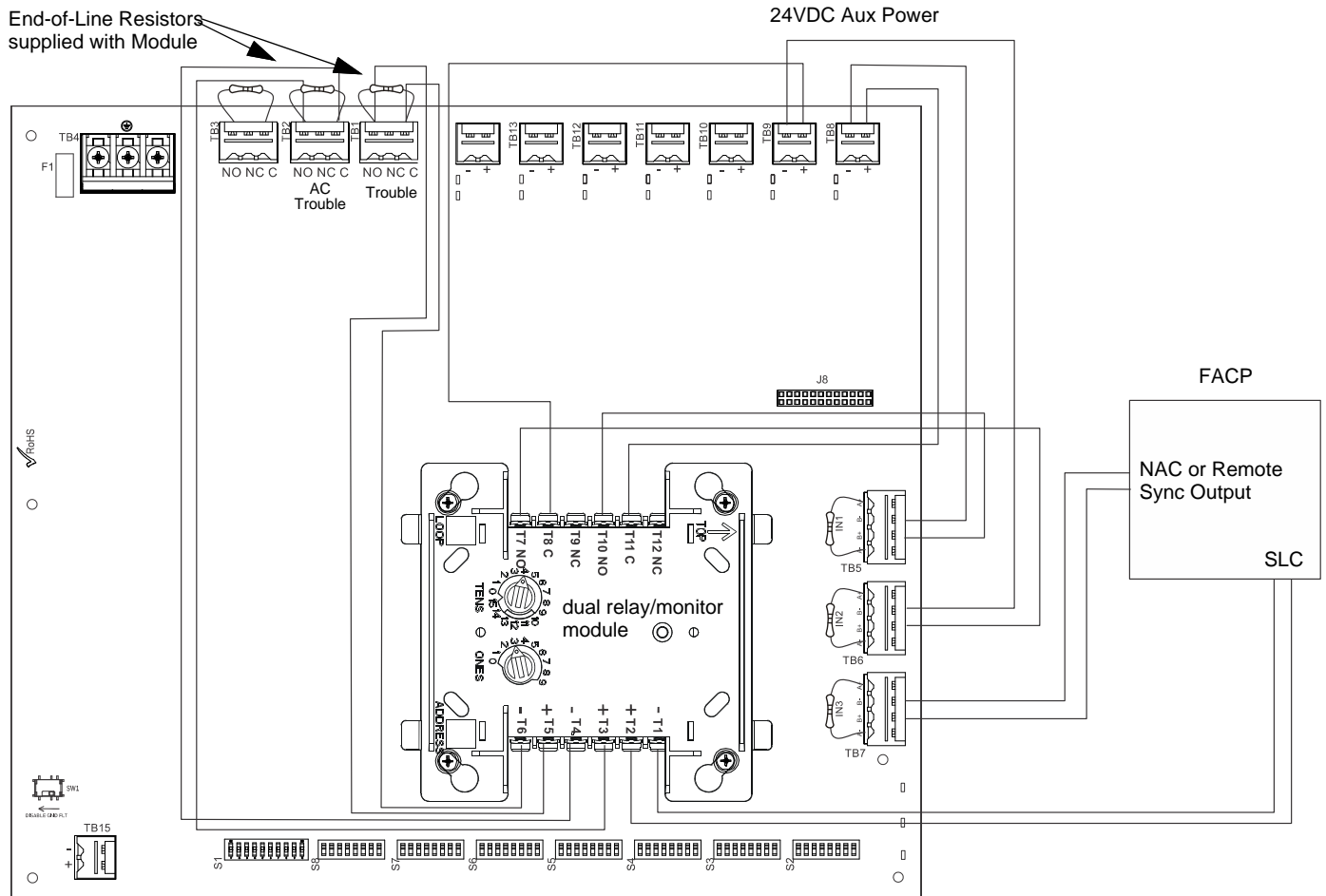

Figure B.4 Controlling NACs, Aux Power, and Door Holders with One Input and NAC Sync

The following notes apply to Figure B.4.

- Any output circuit can be configured as NAC, door holder, or 24VDC power.
- Refer to Section 3 for instructions on setting the DIP switches.
- Do not loop wires under screw terminals. Break wires to maintain proper supervision.
- An End-of-Line Resistor must be installed between terminals 1 and 4 for module wiring supervision (the ELR value is dependent on the module/FACP employed).
- An End-of-line Resistor on input circuits#1-2 (TB5-6) are optional for this particular application.
- Ensure that the dual relay/monitor module is programmed appropriately at the FACP where the inputs are *not* mapped to the same zone as its outputs.
- For a list of compatible devices, refer to the *Device Compatibility Document* for the brand of FACP.
- Refer to the *SLC Wiring Manual* for more information.

B.5 Controlling all Three Inputs with One Control Module

In this application, all three command inputs are being controlled by one multi-control module mounted inside the cabinet. Output #1 is being used for 24 VDC aux power. Any output circuit may be configured to any input.

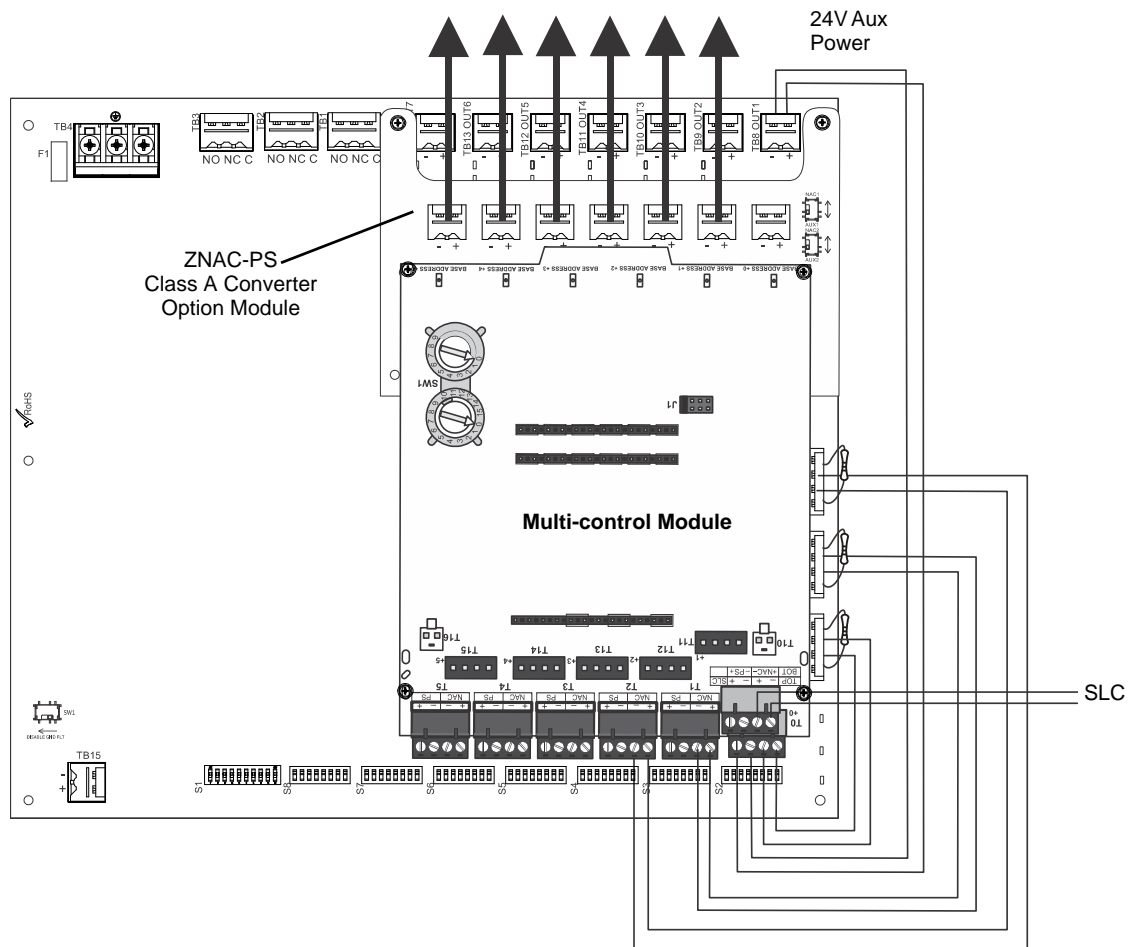

Figure B.5 Controlling Three Inputs with One Module

The following notes apply to Figure B.5.

- An End-of-Line Resistor must be installed between terminals 1 and 4 for control module wiring supervision (the ELR value is dependent on the module/FACP employed).
- Either disable the unused addresses or install ELRs across unused outputs on the Multi-Control Module.
- Refer to Section 3 for instructions on setting the DIP switches.
- Do not loop wires under screw terminals. Break wires to maintain proper supervision.
- For a list of compatible devices, refer to the *Device Compatibility Document* for the brand of FACP.
- Refer to the *SLC Wiring Manual* for more information.

B.6 AC Trouble Reporting with a Conventional FACP

In this application, the power supply is being used with a conventional FACP that does not have a type-coded input zone for AC Power loss with a delay. The AC Trouble Delay on the power supply must be set to none (S1-7 ON, 8 ON). AC Fail delay timers must be set on the DACT. The DACT must be installed in close proximity to the conventional FACP so the audible and visual signaling can be given locally at the FACP as required by UL 864.

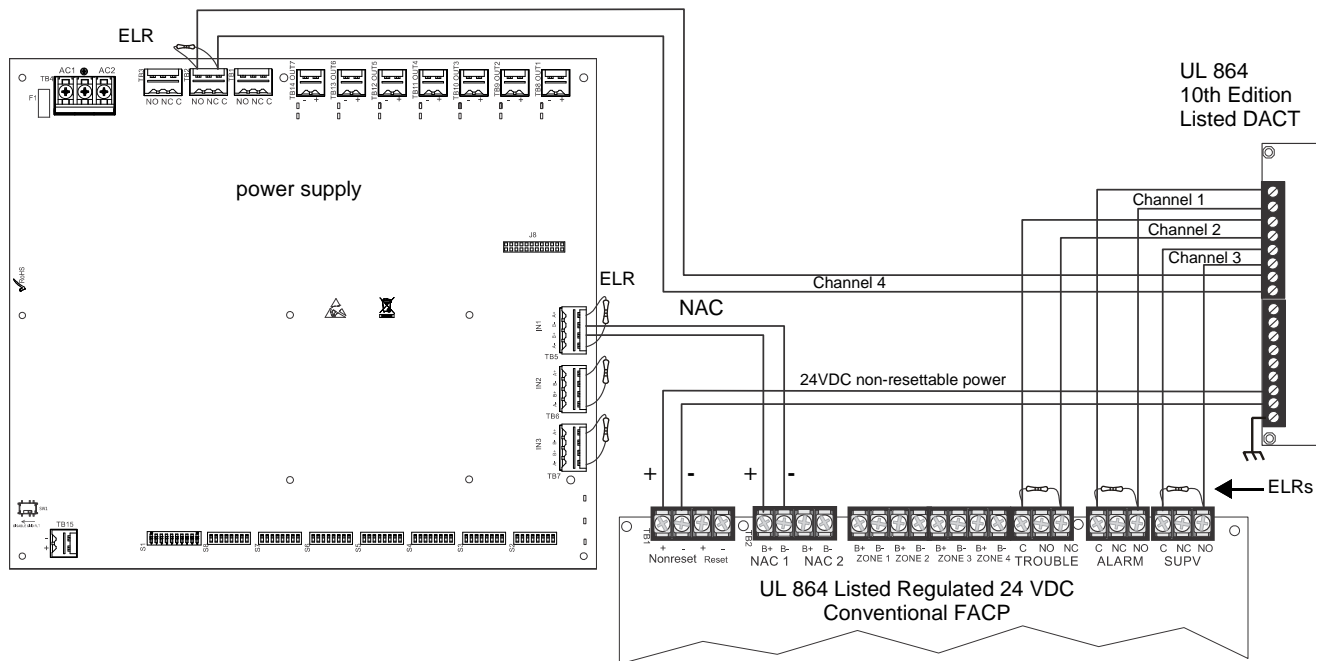

Figure B.6 AC Trouble Reporting with a Conventional FACP

The following notes apply to Figure B.6.

- Wiring from the power supply to the DACT must be in metal conduit within 20 feet of the FACP.
- Refer to Section 3 for instructions on setting the DIP switches.
- Do not loop wires under screw terminals. Break wires to maintain proper supervision.
- An End-of-Line Resistor must be installed between terminals 1 and 4 on the input circuits that require wiring supervision. (The ELR value is dependent on the FACP employed).
- Refer to panel/DACT documentation for programming information.

B.7 Canadian Two-Stage

In this application, NAC1 from the Host FACP is providing the Canada 2-stage audible pattern to the power supply and NAC. NAC2 is providing Master Sync or a Steady Output, depending on its capabilities.

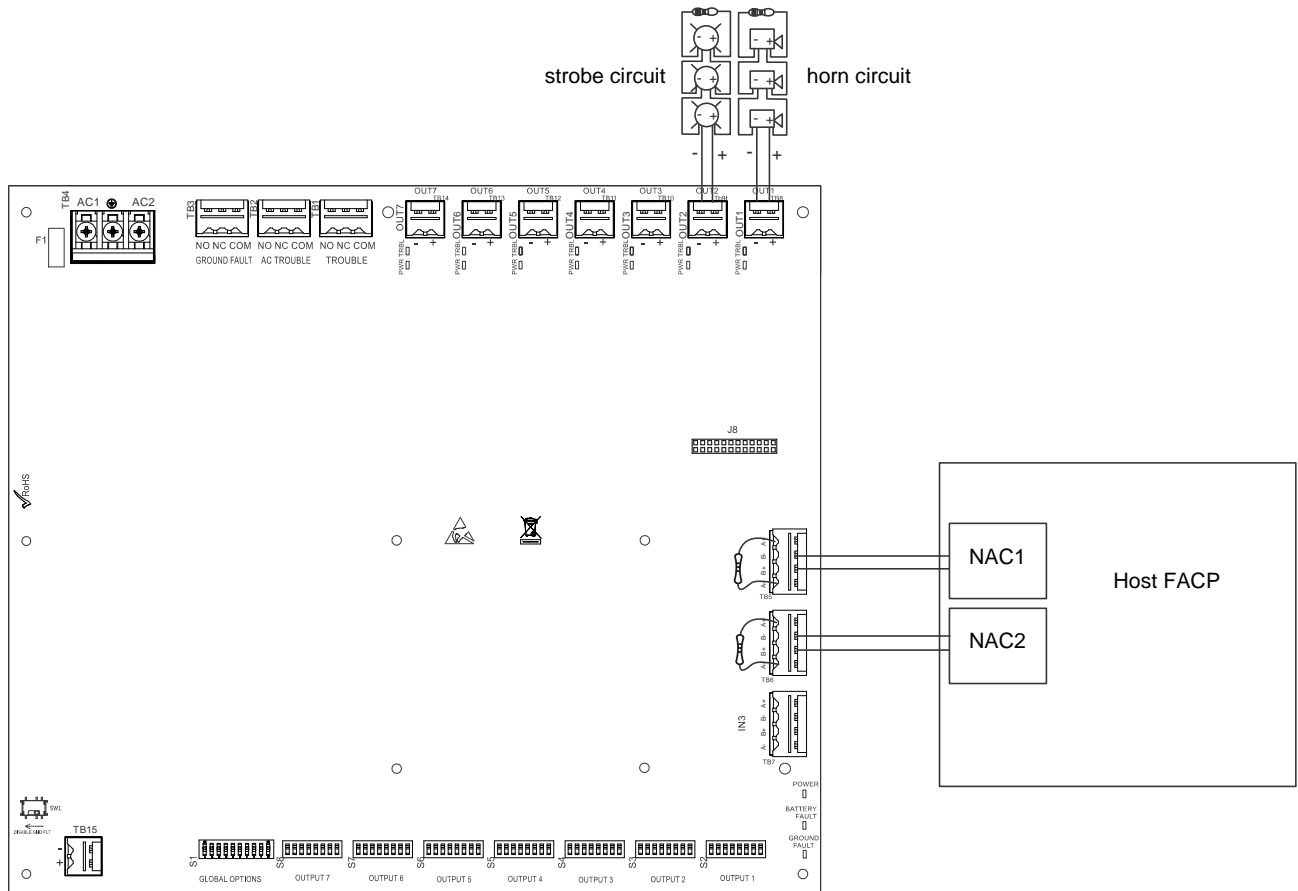

Figure B.7 Canadian Two-Stage Wiring

The following notes apply to Figure B.7.

- Power supply Output #1 is programmed to activate on Command Input #1 and Slave Configuration (NAC follower).
- Power supply Output #2 is programmed depending on the host FACP capabilities.
 - FACP NAC2 provides master sync: power supply Output #2 activate on Command Input 2, Slave Configuration (NAC follower)
 - FACP NAC2 provides steady output: power supply Output #2 activate Command Input 2, Master Configuration (select appropriate strobe manufacturer)
- Additional power supply outputs can be mapped to command inputs and used to drive additional visual/audible or power supply units.

B.8 Canada Two-Stage Application Using a Multi-Control Module

In this application, two outputs are being controlled by a multi-control inside the cabinet. NAC1 from the host FACP is providing the Canada two-stage audible pattern to the HPF-PS. NAC2 is providing master sync or a steady output, depending on its capabilities. Additional power supply outputs can be used to connect to multi-control modules outside the cabinet.

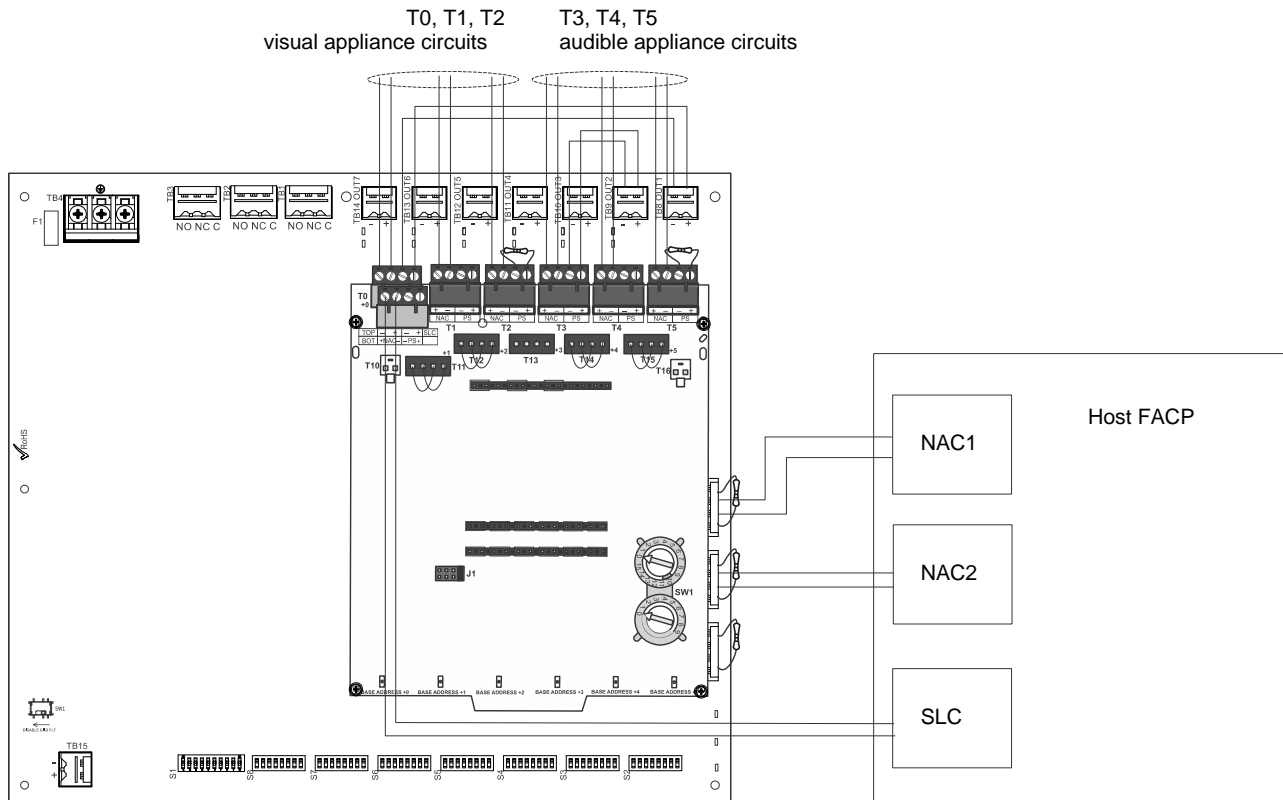

Figure B.8 Canadian Two-Stage Wiring Using a Multi-Control Module

The following notes apply to Figure B.8.

- Power supply Output #1 is programmed to activate on Command Input #1 and Slave Mode (NAC Follower).
- Power supply Output #2 is programmed depending on host FACP capabilities:
 - FACP NAC2 provides master sync: power supply output #2 activate on Command Input 2, Slave Configuration (NAC follower)
 - FACP NAC2 provides steady output: power supply output #2 activate Command Input 2, Master Configuration (select appropriate strobe manufacturer)
- Jumpers must be installed on terminals T11, T12, T14, and T15 of the multi-control module.
- Unused control module NAC outputs need ELRs installed or must be disabled.
- Power supply outputs going to the multi-control module need ELRs installed.
- Due to the reverse-polarity supervision of the power supply outputs, the multi-control module points must have the type code, “Bell Circuit”, to prevent “Ext Power Loss” troubles.

Index

A

- AC power **9**
 - calculations **36**
 - current **9, 11**
 - fail **26**
 - fail delay **26**
 - loss **8**
 - loss relay **9**
 - loss reporting delay **8, 35**
 - loss timer **24**
 - voltage **9**
- activation
 - reverse polarity **8**
- alarm condition **8**
- applications **8**
- aux power **27**
- aux power control
 - see also resettable or non-resettable power **28**

B

- backbox dimensions **12**
- battery **20**
 - capacity **9**
 - charge current **9**
 - charger capacity **8**
 - float charge voltage **9**
 - lead acid **8, 9**
 - maximum capacity **8**
 - see also secondary power **9**
 - trouble **8**

C

- cabinet
 - see also backbox **12**
- Canadian applications **20**
- capacity
 - battery **9**
- cascading **19, 20**
- charge current
 - maximum **9**
 - nominal **9**
- charger
 - enable/disable **25**
- charger trouble **8**
- circuit board
 - layout **10**
- Class A Converter Module **13**
 - see also ZNAC-PS **8**
- Class B **8**
- coding
 - NAC **8**
- command circuit **8**
 - current **9**
 - see also input circuit **9**
 - voltage **9**
- command input **25**
- compatibility
 - input circuit **8**
- current

- maximum continuous **8**
- maximum short term **8**
- standby **9**
- total continuous **9**
- total short term **9**

D

- daisy-chain **20**
- debounce/dejitter **24**
- default mode **8, 24, 26**
- dimensions
 - backbox **12**
- DIP switch
 - settings **24, 27**
- disable outputs **28**
- door holder **29**
 - dropout delay **24**

E

- ELR **9, 13, 33, 41, 42, 43, 44, 45, 46**

F

- factory default **28**
- faults **33**
- features **8**
- filtered power **8**
- float charge voltage **9**
- form-C
 - see also relay **8**

G

- ground cables **20**
- ground fault **8, 19, 21**
- ground fault detection **8, 10**
 - switch SW1 **10**

H

- hardware kit **20**

I

- input **25**
 - current **9**
 - settings **27, 28**
 - voltage **9**
- input #1 sync configuration **25**
- input circuit **8**
 - activation **8**
 - compatibility **8**
 - see also control **9**
- installation **12**

K

- kit **20**

M

- master configuration **29**
- module
 - mounting **14**

- mounting
 - see also installation **12**
- multi-module
 - mounting **15**

N

- NAC
 - activation **8**
 - circuit wiring **13**
 - Class
 - see also NFPA Class **8**
 - coding **8**
 - output
 - see also output circuit **9**
 - see also Notification Appliance Circuit **8**
- NEC power-limited wiring requirements **16**
- non-alarm state **8**
- non-resettable power **27, 28**
- notification appliance circuit
 - see also NAC **8**

O

- operating mode **24, 26**
- output
 - disable **28**
 - unused **28**
- output circuit **9**
 - Class **9**
 - current **9**
 - maximum current **8, 9**
 - see also NAC output **9**
 - types **9**
 - voltage rating **9**
- output power **8**

P

- power
 - non-resettable **8**
 - resettable **8**
- power supply **36**
 - board layout drawing **10**
 - connectors and switches **10**
- power-limited outputs **8**
- power-limited wiring **16**

R

- relay
 - general trouble **34**
 - trouble **8, 9**
- reporting delay
 - AC loss **35**
- requirements **36**
- resettable power **27, 28**
- retrofit mode **8, 24, 26, 31, 32**

S

- secondary power
 - see also battery **9**
- selective silence **29**

- slave configuration **27, 29**
- special operating mode **26**
- specifications **9**
- startup procedure **10**
- strobe synchronization **8**
- supervision **8**
 - trouble **33**
- SW1
 - ground fault detection **10**
- switch
 - SW1 ground fault detection **8, 10**
- sync **29**
- sync configuration **25**
- sync type **17, 29**
- synchronization
 - ADA compatible **8**
 - selectable **8**

T

- trouble **34**
 - power supply **8**
 - supervision **33**
- trouble relay **8, 9, 34**
 - contact rating **9**
- trouble supervision **8**

W

- wiring **8**
 - AC power **9**
 - power-limited **16**

Z

- ZNAC-PS **13, 15**
 - see also Class A Converter Module **8**

Manufacturer Warranties and Limitation of Liability

Manufacturer Warranties. Subject to the limitations set forth herein, Manufacturer warrants that the Products manufactured by it in its Northford, Connecticut facility and sold by it to its authorized Distributors shall be free, under normal use and service, from defects in material and workmanship for a period of thirty six months (36) months from the date of manufacture (effective Jan. 1, 2009). The Products manufactured and sold by Manufacturer are date stamped at the time of production. Manufacturer does not warrant Products that are not manufactured by it in its Northford, Connecticut facility but assigns to its Distributor, to the extent possible, any warranty offered by the manufacturer of such product. This warranty shall be void if a Product is altered, serviced or repaired by anyone other than Manufacturer or its authorized Distributors. This warranty shall also be void if there is a failure to maintain the Products and the systems in which they operate in proper working conditions.

MANUFACTURER MAKES NO FURTHER WARRANTIES, AND DISCLAIMS ANY AND ALL OTHER WARRANTIES, EITHER EXPRESSED OR IMPLIED, WITH RESPECT TO THE PRODUCTS, TRADEMARKS, PROGRAMS AND SERVICES RENDERED BY MANUFACTURER INCLUDING WITHOUT LIMITATION, INFRINGEMENT, TITLE, MERCHANTABILITY, OR FITNESS FOR ANY PARTICULAR PURPOSE. MANUFACTURER SHALL NOT BE LIABLE FOR ANY PERSONAL INJURY OR DEATH WHICH MAY ARISE IN THE COURSE OF, OR AS A RESULT OF, PERSONAL, COMMERCIAL OR INDUSTRIAL USES OF ITS PRODUCTS.

This document constitutes the only warranty made by Manufacturer with respect to its products and replaces all previous warranties and is the only warranty made by Manufacturer. No increase or alteration, written or verbal, of the obligation of this warranty is authorized. Manufacturer does not represent that its products will prevent any loss by fire or otherwise.

Warranty Claims. Manufacturer shall replace or repair, at Manufacturer's discretion, each part returned by its authorized Distributor and acknowledged by Manufacturer to be defective, provided that such part shall have been returned to Manufacturer with all charges prepaid and the authorized Distributor has completed Manufacturer's Return Material Authorization form. The replacement part shall come from Manufacturer's stock and may be new or refurbished. THE FOREGOING IS DISTRIBUTOR'S SOLE AND EXCLUSIVE REMEDY IN THE EVENT OF A WARRANTY CLAIM.

Warn-HL-08-2009.fm

