

250 PSI Butterfly Valves

Ductile Iron Body • Extended Neck • Geometric Drive • Molded-In Seat Liner • Lug and Wafer Style

Sizes 2" through 12"

Install between Std. ASME Class 125/150 flanges.
Lug Style 250 PSI bi-directional dead end service rating without a downstream flange required.

THIRD PARTY CERTIFIED BY QAI TO MEET MSS SP-67 STANDARD • U.S. COAST GUARD "CATEGORY A" • CERTIFIED LEAD-FREE* BY TRUESDAIL LABS TO NSF/ANSI/CAN 61-8 COMMERCIAL HOT 180°F AND NSF/ANSI/CAN 61 AND 372

MATERIAL LIST

PART	SPECIFICATION
1. Stem	Stainless Steel ASTM A582 Type 416
2. Collar Bushing	Brass ASTM B16
3. Stem Seal	EPDM Rubber
4. Body Seal	EPDM Rubber
5. Nameplate	Aluminum
6. Upper Bushing	Copper CDA 122
7. Liner	EPDM Rubber
8. Disc	Alum. Brz. ASTM B148 Alloy 954/955
9. Lower Bushing	Copper CDA 122
10. Body Wafer	Ductile Iron ASTM A536
11. Body Lug	Ductile Iron ASTM A536

NOT RECOMMENDED FOR STEAM SERVICE



WD-3000
Wafer Style
EPDM Liner
and Aluminum
Bronze Disc



LD-3000
Lug Style
EPDM Liner
and Aluminum
Bronze Disc

DIMENSIONS — WEIGHTS

Size	In.						G		Metal		Rubber		J		N	
	mm.	A	B	C	D	E	F	Flat	H	I	Square	Di.	Di.	Di.	Di.	Di.
2	50	2.53	4.00	1.25	5.38	2.88	.38	.312	1.688	1.812	3.25	.500				
2 1/2	65	2.90	4.69	1.25	5.88	3.27	.38	.370	1.812	1.938	3.25	.562				
3	80	3.15	5.12	1.25	6.12	3.40	.38	.370	1.812	1.938	3.25	.562				
4	100	4.09	6.12	1.25	6.88	4.00	.38	.403	2.062	2.188	3.25	.625				
5	125	5.13	7.25	1.25	7.38	4.75	.38	.496	2.188	2.312	3.25	.750				
6	150	6.13	8.25	1.25	8.00	5.29	.38	.496	2.188	2.312	3.25	.750				
8	200	8.13	10.41	1.25	9.25	6.50	.50	.560	2.375	2.500	3.25	.875				
10	250	10.13	12.52	1.25	10.50	8.00	.50	.686	2.688	2.812	4.75	1.125				
12	300	12.13	15.00	1.25	12.00	9.25	.50	.748	3.000	3.125	4.75	1.250				

Size	Capscrew/Stud Data						Wafer Length	Lug Length	M	Lug Weight		Wafer Weight	
	In.	mm.	B.C.	Di.	Di.	No.				B.C.	Lbs.	Kg.	Lbs.
2	50	3.25	.437	.437	4	5/8-11unc	Refer to butterfly valve technical information for bolt lengths	4 3/4	7	3.2	5.5	2.5	
2 1/2	65	3.25	.437	.500	4	5/8-11unc		5 1/2	9	4.1	7.5	3.4	
3	80	3.25	.437	.500	4	5/8-11unc		6	9.5	4.3	8	3.6	
4	100	3.25	.437	.562	8	5/8-11unc		7 1/2	15	6.8	11	5.0	
5	125	3.25	.437	.656	8	3/4-10unc		8 1/2	21	9.5	15	6.8	
6	150	3.25	.437	.656	8	3/4-10unc		9 1/2	24	10.9	18	8.2	
8	200	3.25	.437	.781	8	3/4-10unc		11 3/4	34	15.4	28	12.7	
10	250	5.00	.562	1.000	12	7/8-9unc		14 1/4	62	28.1	45.5	20.7	
12	300	5.00	.562	1.062	12	7/8-9unc		17	90	40.9	70	31.8	

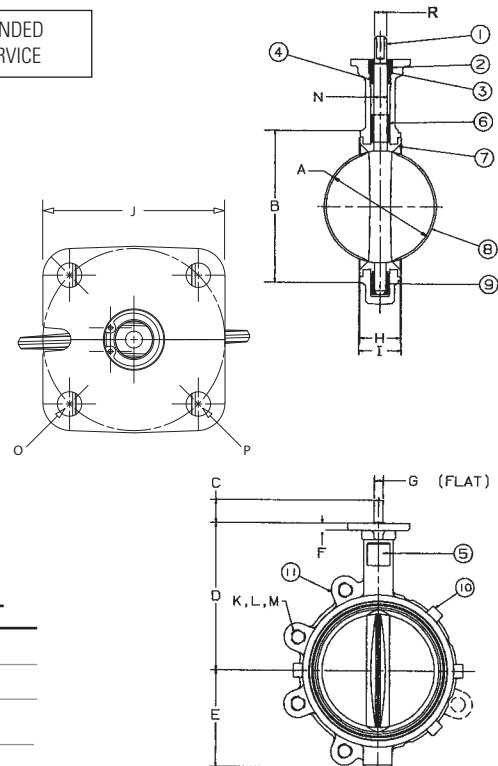

WARNING: This product can expose you to chemicals including lead, which is known to the State of California to cause cancer and birth defects or other reproductive harm. For more information go to www.P65Warnings.ca.gov.

*Weighted average lead content ≤ 0.25%

Visit our website for the most current information.