

Bronze Ball Valves

Three-Piece Body • Full Port • Bronze Trim • Blowout-Proof Stem

600 PSI/41.4 bar non-shock cold working pressure
150 PSI/10.3 bar saturated steam*

CONFORMS TO MSS SP-110



MATERIAL LIST

PART	SPECIFICATION
1. Handle Nut	Zinc Plated Steel
2. Handle	Zinc Plated Steel Clear Chromate Plastisol Coated
3. Threaded Pack Gland	Brass ASTM B 16 Alloy C36000
4. Stem	Silicon Bronze ASTM B 371 Alloy C69430 or ASTM B 99 Alloy C65100
5. Body	Bronze ASTM B 584 Alloy C84400
6. Packing	PTFE
7. Body End (2)	Bronze ASTM B 584 Alloy C84400
8. O-Ring Seal (2)	FKM
9. Seat Ring (2)	PTFE (Y) or Reinforced PTFE (R)
10. Ball	Brass ASTM B 124 Alloy C37700 or ASTM B16 Alloy C36000 EACH with Hard Chrome Plate
11. Thrust Washer	Reinforced PTFE
12. Body Bolts	Zinc Dichromate Plated Steel ASTM A 449 Grade 5
13. Body Nuts	Zinc Dichromate Plated Steel ASTM A 449 Grade 5

Note: valves are static grounded by a grounding washer. (not shown)

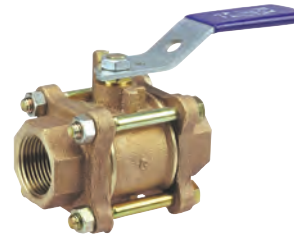

T-595-Y/R
Threaded



S-595-Y/R
Solder

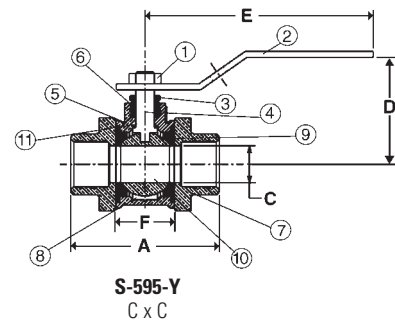
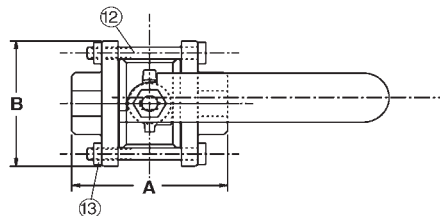
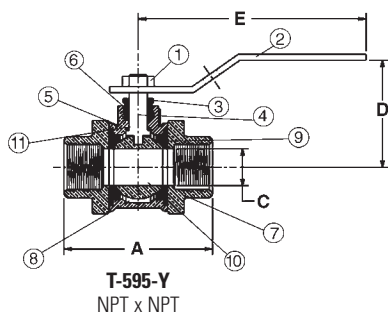

DIMENSIONS—WEIGHTS—QUANTITIES

Size	T-595-Y		S-595-Y		Dimensions							S-595-Y				Master Ctn. Qty.				
	In. mm.	In. mm.	A	A	B	C	D	E	F	T-595-Y	S-595-Y	Lbs.	Kg.	Lbs.	Kg.					
¼	8	2.50	64	1.69	43	1.81	46	.38	10	1.69	43	3.91	99	.875	.29	1.03	.47	.89	.40	50
⅜	10	2.50	64	1.81	46	1.81	46	.38	10	1.69	43	3.91	99	.875	.29	.98	.44	.89	.40	50
½	15	2.50	64	2.06	52	1.81	46	.50	13	1.69	43	3.91	99	.875	.29	1.03	.47	.89	.40	50
¾	20	3.00	76	2.94	75	1.94	49	.75	19	2.00	51	4.66	118	1.190	.37	1.70	.77	1.59	.72	30
1	25	3.69	94	3.66	93	2.50	64	1.00	25	2.25	57	4.66	118	1.563	.47	2.82	1.28	2.55	1.15	20
1¼	32	4.09	104	3.91	99	2.69	68	1.25	32	2.75	70	6.69	170	1.750	.50	3.96	1.80	3.61	1.64	10
1½	40	4.56	116	4.60	117	3.00	76	1.50	38	2.97	75	6.69	170	2.125	.60	5.68	2.57	5.31	2.41	10
2	50	6.16	156	5.78	147	4.00	102	2.00	51	3.63	92	6.69	170	2.640	.78	11.40	5.17	10.60	4.81	4
2½	65	6.84	174	6.94	176	5.00	127	2.50	64	4.09	104	8.00	203	3.463	1.02	21.07	9.56	19.30	8.75	2

*For detailed operating pressure, refer to pressure temperature chart on page 41.



WARNING: This product can expose you to chemicals including lead, which is known to the State of California to cause cancer and birth defects or other reproductive harm. For more information go to www.P65Warnings.ca.gov.

*Weighted average lead content ≤ 0.25%

Visit our website for the most current information.

**LEAD FREE*
OPTION
AVAILABLE**

**OXYGEN
SERVICE
OPTION
AVAILABLE**