



Tank Heaters

For Heating Water with Steam or Water

C-115E

 **Bell & Gossett**
a xylem brand

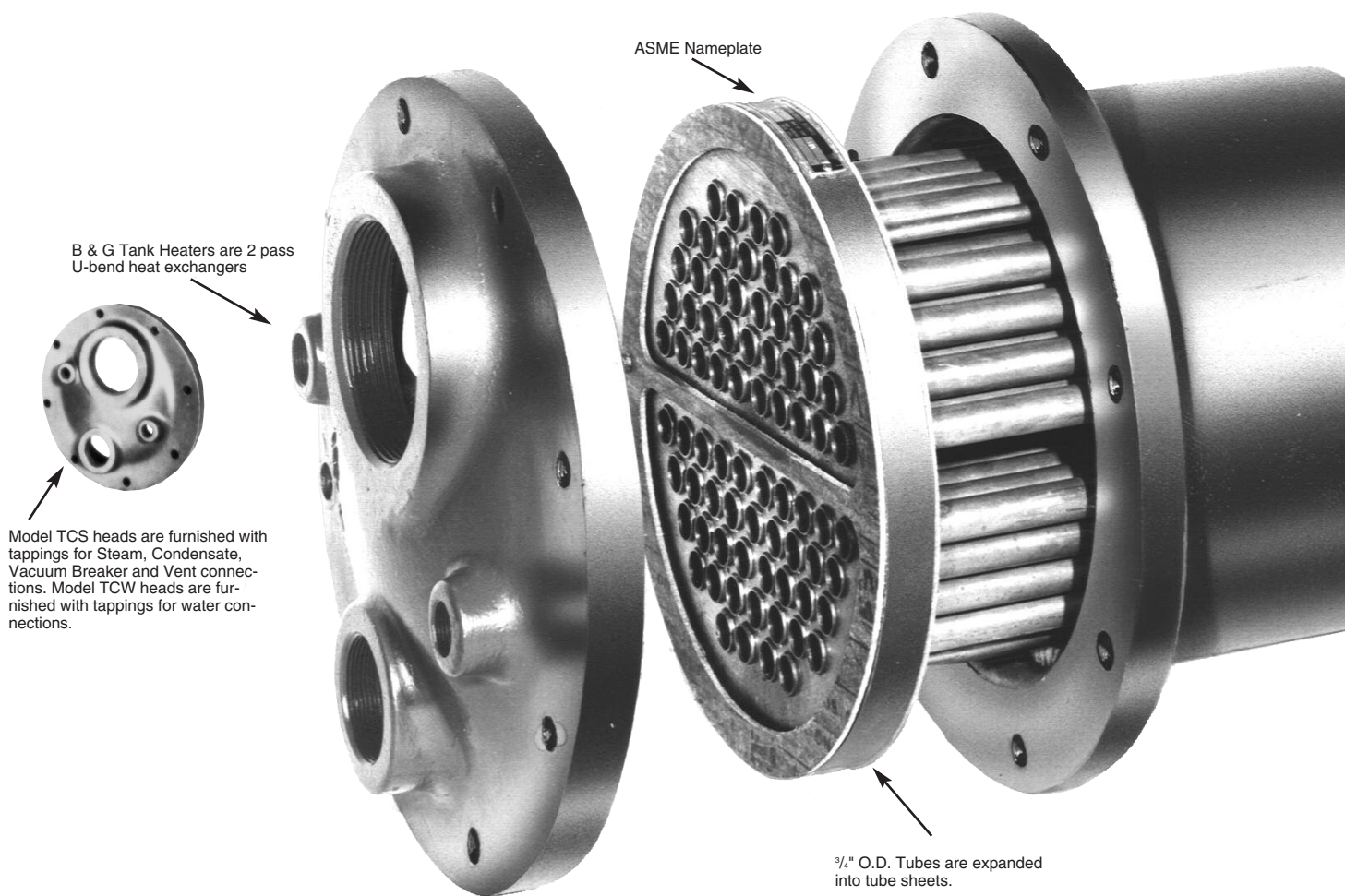

GENERAL INFORMATION

MATERIAL FEATURES

1. Tubes are 3/4" O.D. copper.
2. Heads are cast iron. Brass can be furnished on request.
3. Tube sheets and welding collars are pressure vessel quality steel. Brass tube sheets can be furnished on request.
4. Tube supports are brass.
5. All materials furnished for pressure parts are certified to ASME specifications.
6. Units are available with stainless steel, 90/10 cupro nickel, Admiralty, and steel tubing. Consult factory for other variations.
7. Many Tank Heater applications require lining the tank with various materials i.e., epoxy phenolic, cement, etc. When the thickness of these linings exceed 0.01", oversized construction must be provided. Consult factory.

DESIGN PRESSURES – STANDARD

Cast Iron Head – Steel Tube Sheet – Copper
Tubes – ASME Construction – Design
Temperature 375° F.

Tube Bundle Diameter (Nominal)	Design Pressure	Test Pressure
4"	150 PSI	300 PSI
6"	150 PSI	300 PSI
8"	150 PSI	300 PSI
10"	125 PSI	250 PSI
12"	125 PSI	250 PSI
14"	125 PSI	250 PSI

For design pressure and design temperature for brass construction please consult factory.

For design pressures and temperatures higher than standard consult factory.

For diameters larger than shown consult factory.

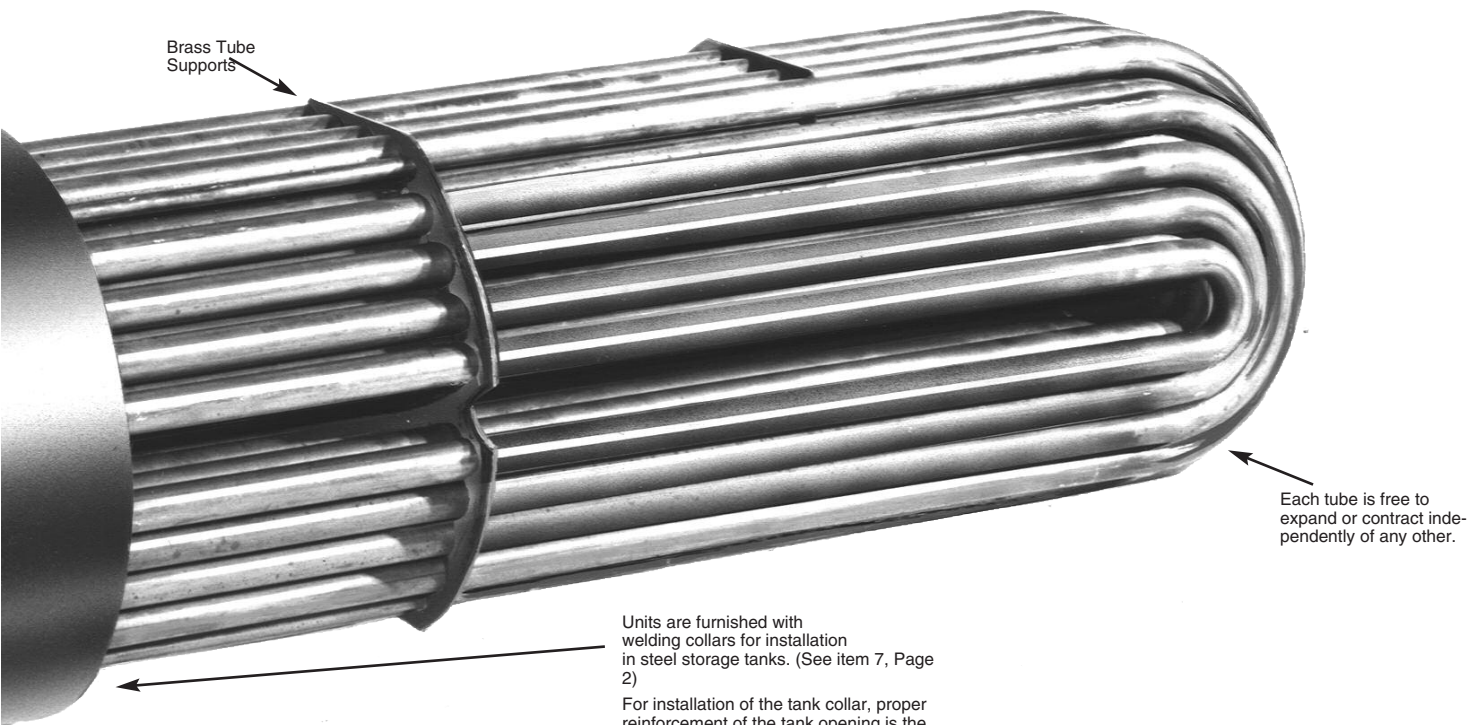

Units are furnished with welding collars for installation in steel storage tanks. (See item 7, Page 2)

For installation of the tank collar, proper reinforcement of the tank opening is the responsibility of the installer.

Standard tank heaters are constructed according to ASME requirements for pressures and temperature noted in table on page 2. A Manufacturer's Partial Data Report for Pressure Vessels, Form No. U-2 as required by the provisions of the ASME Code Rules is furnished with each unit upon request. This form is signed by an authorized inspector, holding a National Board Commission, and who is employed by an authorized inspection agency, certifying that construction conforms to the latest ASME code for pressure vessels. The ASME "U" symbol is stamped on each vessel.

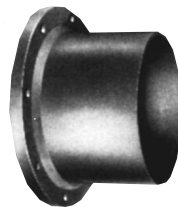

1. Determine Capacity Required:

To determine the heat transfer capacity of the heat exchanger the following conditions of operation must be known:

- a. The amount of water to be heated in gallons per hour.
 - b. Inlet temperature of water and outlet or final water temperature.
 - c. The steam pressure available at the heat exchanger. (Be sure allowance is made for pressure drop through the steam controller.) **Or** if boiler water is the heating medium, the inlet temperature of the water.
- b. Next refer to proper steam temperature or boiler water temperature.
 - c. Select unit from appropriate table or tables.
 - d. Consult factory for all temperature conditions not covered by tables.

2. Select Unit

Select the proper unit by using the tables on Pages 5 thru 7 as follows:

- a. First refer to proper temperature rise.



TANK AND HEATER ASSEMBLY

TYPICAL INSTALLATIONS (TANK AND HEATER UNITS)

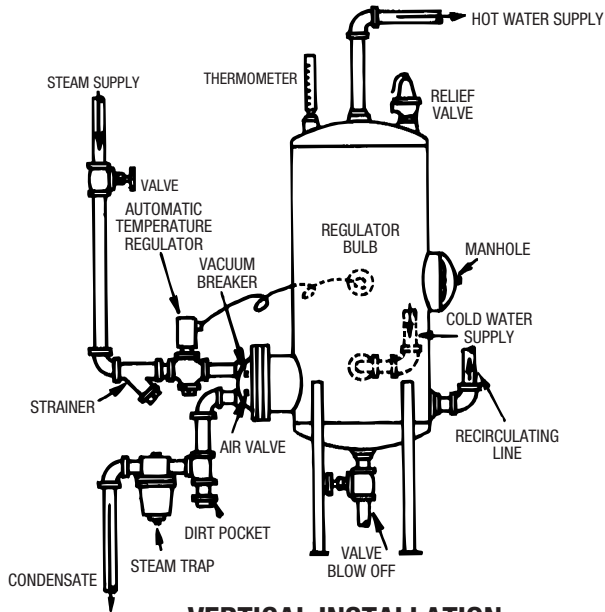

VERTICAL INSTALLATION

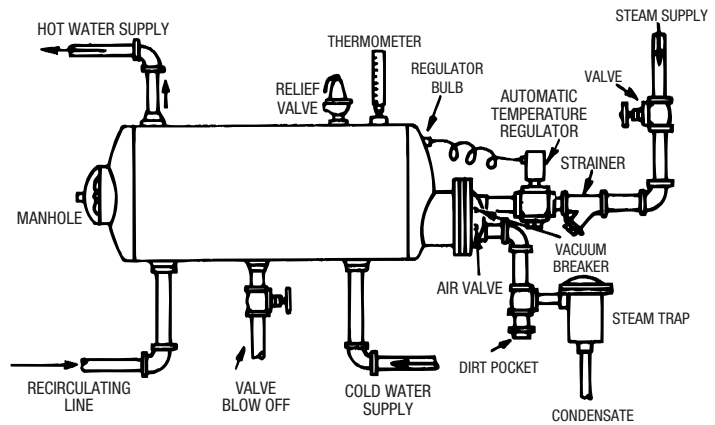

HORIZONTAL INSTALLATION

***Table A....Hot Water Demand per Fixtures for Various Types of Buildings**

Gallons of water per hour per fixture, calculated at a final temperature of 140° F.

	Apartment House	Club	Gymnasium	Hospital	Hotel	Industrial Plant	Office Building	Private Residence	School	Y.M.C.A.
1. Basins, private lavatory	2	2	2	2	2	2	2	2	2	2
2. Basins, public lavatory	4	6	8	6	8	12	6	15	8
3. Bathtubs	20	20	30	20	20	20	30
4. Dishwashers ^a	15	50-150	50-150	50-200	20-100	15	20-100	20-100
5. Foot basins	3	3	12	3	3	12	3	3	12
6. Kitchen sink	10	20	20	30	20	20	10	20	20
7. Laundry, stationary tubs	20	28	28	28	20	28
8. Pantry sink	5	10	10	10	10	5	10	10
9. Showers	30	150	225	75	75	225	30	30	225	225
10. Slop sink	20	20	20	30	20	20	15	20	20
11. Hydro-therapeutic showers				400						
12. Hubbard baths				600						
13. Leg baths				100						
14. Arm baths				35						
15. Sitz baths				30						
16. Continuous-flow baths				165						
17. Circular wash sinks				20	20	30	20		30	
18. Semi-circular wash sinks				10	10	15	10		15	
19. Demand factor	0.30	0.30	0.40	0.25	0.25	0.40	0.30	0.30	0.40	0.40
20. Storage capacity factor ^b	1.25	0.90	1.00	0.60	0.80	1.00	2.00	0.70	1.00	1.00

^aDishwasher requirements should be taken from this table or from manufacturer's data for the model to be used, if this is known.

^bRatio of storage tank capacity to probable maximum demand per hour. Storage capacity may be reduced where an unlimited supply of steam is available from a central street steam system or larger boiler plant.

^cCopyright by ASHRAE. Reprinted by permission from ASHRAE 1980 Systems Handbook.

EXAMPLE – USING TABLE A:

Suppose we consider an apartment building having the following fixtures:

Private lavatories	12 at 2 gals. each =	24 G.P.H.
Public lavatories	4 at 4 gals. each =	16 G.P.H.
Bath tubs	12 at 20 gals. each =	240 G.P.H.
Dishwashers	5 at 15 gals. each =	75 G.P.H.
Kitchen sinks	12 at 10 gals. each =	120 G.P.H.
Laundry tubs	12 at 20 gals. each =	240 G.P.H.
Slop sinks	2 at 20 gals. each =	40 G.P.H.
Possible max. demand		755 G.P.H.

The demand factor is .30, therefore the recovery rate or probable Max. demand is 755 G.P.H. x .30 or 266 G.P.H. at 140°.

The storage capacity factor is 1.25, therefore, the storage capacity is 266 G.P.H. x 1.25 or 282 gallons.

Assuming the tank is horizontal and uncirculated, 30" in diameter at 96" long with steam at 10 PSIG available at the coil and holding the coil as near to 50 to 75% of the tank length – choose a TCS-466. Reference Selection Procedure, Page 5.

CAUTION: It is up to the installer to provide adequate support for units (2) two feet or longer when installing this unit in a tank. Failure to provide adequate support may result in premature tube failure and/or failure of the tube/tubesheet mechanical roll joint.

RATINGS ... B & G TANK HEATERS

TABLE 1 – TYPE TCS CAPACITY – GPH/SQ. FT. (HEATING WATER)

(Red indicates capacity on circulated tank
Black indicates capacity based on uncirculated (stagnant) tank)

WATER TEMP.		STEAM (TUBE SIDE) – PSIG											
FROM	TO	0	2	5	10	15	20	30	40	50	75	100	125
40	120	53.5	56.3	60.0	65.3	69.7	73.5	80.0	85.4	90.0	99.5	107.1	113.4
		29.1	30.9	33.3	36.5	39.5	41.9	46.2	49.6	52.6	59.2	64.1	68.7
40	140	38.4	40.8	43.8	48.1	51.7	54.8	60.0	64.4	68.2	75.8	81.8	86.9
		23.1	24.7	26.7	29.6	32.2	34.2	37.9	41.1	43.7	49.4	53.7	57.6
40	160	28.0	30.0	32.7	36.3	39.4	42.1	46.5	50.2	53.4	59.8	64.9	69.2
		18.1	19.6	21.5	24.1	26.4	28.4	31.7	34.4	36.9	41.8	45.9	49.4
40	180	19.9	21.8	24.3	27.6	30.4	32.8	36.7	39.9	42.7	48.3	52.8	56.4
		13.8	15.2	17.1	19.6	21.7	23.5	26.6	29.2	31.4	36.0	39.7	42.7
50	120	59.2	62.4	66.6	72.6	77.6	82.0	89.4	95.5	100.8	111.6	120.2	127.4
		32.5	34.4	37.0	40.8	43.9	46.7	51.6	55.4	59.2	66.4	71.9	77.2
50	140	41.3	43.8	47.2	51.9	55.9	59.4	65.2	70.0	74.1	82.6	89.3	95.0
		24.9	26.6	28.8	32.0	34.9	37.2	41.3	44.6	47.6	53.9	58.9	63.0
50	160	29.5	31.6	34.5	38.5	41.9	44.7	49.6	53.6	57.0	64.0	69.6	74.2
		19.2	20.8	22.8	25.7	28.1	30.1	33.8	36.9	39.4	45.0	49.4	52.9
50	180	20.6	22.7	25.3	28.9	31.8	34.4	38.6	42.0	45.0	51.0	55.8	59.7
		14.4	15.9	17.9	20.5	22.8	24.8	28.1	30.7	33.2	38.0	42.0	45.4
60	120	66.7	70.4	75.3	82.2	88.1	93.2	101.8	108.9	115.1	127.6	137.7	146.1
		36.3	38.6	41.6	46.0	49.6	52.8	58.4	62.8	66.8	75.5	82.4	87.9
60	140	44.8	47.6	51.4	56.7	61.1	65.0	71.5	76.9	81.6	91.1	98.6	104.9
		27.0	28.8	31.3	34.9	37.9	40.5	45.1	49.1	52.3	59.1	64.7	69.2
60	160	31.2	33.6	36.7	41.1	44.7	47.9	53.2	57.5	61.3	69.0	75.1	80.2
		20.3	22.0	24.2	27.4	30.0	32.2	36.2	39.6	42.4	48.2	53.0	57.2
60	180	21.5	23.7	26.4	30.3	33.5	36.2	40.7	44.4	47.6	54.1	59.2	63.5
		15.0	16.6	18.7	21.6	24.0	26.1	29.6	32.5	35.2	40.3	44.6	48.0

The capacity of a tank heater depends on a number of factors which include the orientation of the tank heater (vertical or horizontal), the location of the tank heater (top or bottom of tank), the duty of the tank heater (cooling or heating), and whether the tank is circulated or uncirculated.

Table 1 capacities are based on a horizontal tank heater, which is heating the tank water, with the unit located along the lower portion of the tank (Reference Typical Installations). Furthermore, there are two capacities shown for each set of conditions of water temperature and steam pressure. The capacities in "Black" are GPH/Sq. Ft. for an uncirculated (Stagnant) tank. The capacities in "Red" are GPH/Sq. Ft. for a circulated tank having the cold water inlet directed across the tube bundle or heat transfer surface.

1. Selection Procedure

Example

Size tank heater unit capable of heating 1000 GPH from 40°F to 160°F with 20 PSIG saturated steam.

Solution

- Step 1 – Determine whether tank is circulated or uncirculated.
- Step 2 – Refer to Table 1 Capacity. Based on water temperature and steam pressure, obtain capacity, 42.1 for circulated and (28.4) for uncirculated tank.
- Step 3 – $\frac{1000 \text{ GPH}}{42.1 \text{ GPH/Sq. Ft.}}$ or $\frac{1000 \text{ GPH}}{28.4 \text{ GPH/Sq. Ft.}}$
= 23.7 or (35.2)
- (Required clean tube heating surface)

Note: A DTCS Diamondback™ double wall unit may be selected by multiplying capacity in Step 3 by 1.05 (for uncirculated tank) or 1.17 (for circulated tank).

- Step 4 – Select a tank heater from Table 4 – Dimensions – with required heating surface available, TCS-666 or (TSC-696).

Allowance for fouling can be made by either increasing length of unit or by selecting a unit in the next larger diameter.

RATINGS ... B & G TANK HEATERS (UNCIRCULATED TANK)

Capacities of B & G Tank Heaters in table below are in GPH (gallons per hr.) when installed in steel tanks.

TABLE 2 – TYPE TCW (3/4" O. D. COPPER TUBES) HEATING WATER 40°-140°F

BOILER WATER IN TUBES				
HEATER NO.	180° PUMPED	MIN** B. W. REQ'D.	212° PUMPED	MIN.** B. W. REQ'D.
TCW-412	12	1	25	2
TCW-418	23	2	50	5
TCW-424	38	3	77	7
TCW-430	53	5	103	9
TCW-436	70	6	130	11
TCW-442	86	7	159	14
TCW-448	104	9	187	16
TCW-454	122	10	216	19
TCW-460	138	12	243	21
TCW-466	156	14	272	23
TCW-472	173	15	301	26
TCW-484	209	18	359	31
TCW-496	244	21	409	35
TCW-612	19	3	32	3
TCW-618	34	3	79	7
TCW-624	64	6	132	12
TCW-630	94	8	184	16
TCW-636	127	11	240	21
TCW-642	160	14	294	25
TCW-648	194	17	351	30
TCW-654	228	20	407	35
TCW-660	263	23	464	40
TCW-666	297	26	520	45
TCW-672	332	29	578	50
TCW-684	402	34	692	60
TCW-696	473	40	806	69
TCW-818	71	6	161	14
TCW-824	121	11	249	22
TCW-830	175	15	341	30
TCW-836	230	20	434	37
TCW-842	286	25	528	45
TCW-848	358	31	647	56
TCW-854	423	36	754	65
TCW-860	489	42	863	74
TCW-866	548	47	960	82
TCW-872	607	52	1056	91
TCW-884	742	63	1274	109
TCW-896	876	75	1493	128
TCW-1024	224	19	456	39
TCW-1030	325	28	628	54
TCW-1036	429	37	803	69
TCW-1042	536	46	981	84
TCW-1048	629	54	1134	97
TCW-1054	738	63	1314	113
TCW-1060	848	72	1495	128
TCW-1066	959	82	1676	144
TCW-1072	1070	91	1858	159
TCW-1084	1293	110	2222	190
TCW-1096	1518	129	2588	222
TCW-10108	1745	148	2957	253
TCW-1236	625	53	1167	100
TCW-1242	780	67	1428	122
TCW-1248	938	80	1690	145
TCW-1254	1098	93	1952	167
TCW-1260	1245	106	2193	188
TCW-1266	1407	120	2460	211
TCW-1272	1570	133	2724	233
TCW-1278	1734	147	2990	256
TCW-1284	1883	160	3238	277
TCW-1296	2214	188	3770	323*
TCW-12108	2546	216	4310	369*
TCW-12120	2862	243	4832	413*
TCW-1436	891	76	1658	142
TCW-1442	1119	95	2038	175
TCW-1448	1320	112	2370	203
TCW-1454	1539	131	2732	234
TCW-1460	1759	150	3091	265
TCW-1466	1980	168	3455	296
TCW-1472	2188	186	3794	325
TCW-1478	2415	205	4160	356
TCW-1484	2622	223	4495	385
TCW-1496	3072	261	5230	448
TCW-14108	3508	298	5940	508
TCW-14120	3948	335	6650	569

Note: A DTCW Diamond-back™ double wall unit for uncirculated tank conditions may be selected by dividing GPH (Gallons Per Hr.) by 1.10.

Pressure drop through all TCW heaters at maximum flow is approximately .55 ft. for each foot of free tube length.

*Require Fabricated Steel Heads at additional cost. Consult Factory for Dimensions.

**Minimum Boiler Water (BW) required is given in GPM (gallons per minute) based on an approximate 20° drop. Size piping and select B&G Circulating Pump for not less than capacity shown.

Allowance for fouling can be made by either increasing length of unit or by selecting a unit in the next larger diameter.

MAXIMUM BOILER WATER CAPACITIES

Pumped Circulation in TCW Unit

Heater Diameter	Boiler Water In Tubes
4"	51 GPM
6"	102 GPM
8"	187 GPM
10"	323 GPM
12"	467 GPM
14"	637 GPM

RATINGS ... B & G TANK HEATERS (CIRCULATED TANK)

Capacities of B & G Tank Heaters in table below are in GPH (gallons per hr.) when installed in steel tanks.

TABLE 3 – TYPE TCW (3/4" O. D. COPPER TUBES) HEATING WATER 40°-140°F

BOILER WATER IN TUBES				
HEATER NO.	180° PUMPED	MIN** B. W. REQ'D.	212° PUMPED	MIN.** B. W. REQ'D.
TCW-412	15	1	44	4
TCW-418	41	4	92	8
TCW-424	71	6	143	12
TCW-430	100	9	190	16
TCW-436	133	12	243	21
TCW-442	166	14	296	25
TCW-448	200	17	350	30
TCW-454	234	20	403	35
TCW-460	265	23	452	39*
TCW-466	298	26	506	43*
TCW-472	334	28	561	48*
TCW-484	402	34	596	51*
TCW-496	469	40*	—	—
TCW-612	37	5	77	9
TCW-618	85	10	155	15
TCW-624	151	17	243	21
TCW-630	200	20	342	30
TCW-636	240	21	446	39
TCW-642	304	26	548	47
TCW-648	371	32	665	56
TCW-654	436	37	758	65
TCW-660	505	43	865	74
TCW-666	570	49	967	83*
TCW-672	639	54	1075	92*
TCW-684	776	66	1259	98*
TCW-696	912	78*	—	—
TCW-818	198	26	315	30
TCW-824	274	29	460	40
TCW-830	356	34	632	54
TCW-836	435	37	806	69
TCW-842	544	46	981	84
TCW-848	683	58	1202	103
TCW-854	810	69	1406	121
TCW-860	940	80	1608	138
TCW-866	1052	89	1790	154
TCW-872	1168	99	1965	168
TCW-884	1430	121	2295	171
TCW-896	1692	144	—	—
TCW-1024	479	48	842	72
TCW-1030	635	57	1165	100
TCW-1036	813	69	1490	128
TCW-1042	1020	87	1825	156
TCW-1048	1200	102	2110	181
TCW-1054	1414	120	2445	209
TCW-1060	1625	138	2781	238
TCW-1066	1844	157	3120	267
TCW-1072	2060	175	3465	297
TCW-1084	2490	211	4043	315*
TCW-1096	2930	249	—	—
TCW-10108	3370	286	—	—
TCW-1236	1180	100	2170	186
TCW-1242	1484	126	2650	227
TCW-1248	1790	152	3147	269
TCW-1254	2107	179	3625	310
TCW-1260	2385	203	4080	349*
TCW-1266	2705	230	4580	392*
TCW-1272	3020	256	5010	408*
TCW-1278	3340	284	5440	423*
TCW-1284	3630	308	5890	458*
TCW-1296	4270	362*	—	—
TCW-12108	4910	417*	—	—
TCW-12120	5505	467*	—	—
TCW-1436	1689	144	3078	264
TCW-1442	2131	181	3790	324
TCW-1448	2525	214	4410	377
TCW-1454	2950	251	5085	435
TCW-1460	3376	287	5750	492
TCW-1466	3805	323	6430	550
TCW-1472	4215	358	7060	604
TCW-1478	4645	394	7655	624
TCW-1484	5050	429	8180	636
TCW-1496	5930	503	—	—
TCW-14108	6780	575	—	—
TCW-14120	7500	606	—	—

Note: A DTCW Diamond-back™ double wall unit for circulated tank conditions may be selected by dividing GPH (Gallons Per Hr.) by 1.20.

Pressure drop through all TCW heaters at maximum flow is approximately .55 ft. for each foot of free tube length.

*Require Fabricated Steel Heads at additional cost. Consult Factory for Dimensions.

**Minimum Boiler Water (BW) required is given in GPM (gallons per minute) based on an approximate 20° drop. Size piping and select B&G Circulating Pump for not less than capacity shown.

Allowance for fouling can be made by either increasing length of unit or by selecting a unit in the next larger diameter.

MAXIMUM BOILER WATER CAPACITIES

Pumped Circulation in TCW Unit

Heater Diameter	Boiler Water In Tubes
4"	51 GPM
6"	102 GPM
8"	187 GPM
10"	323 GPM
12"	467 GPM
14"	637 GPM

TUBE BUNDLE REPLACEMENT

Bell & Gossett will manufacture a replacement tube bundle assembly for a tank heater of another manufacturer's design at the maximum allowable pressure and temperature based on the data given below. The tubesheet will be of conventional design and the tube supports will be spaced as per B&G standard unless otherwise indicated.

The tube bundle will be constructed according to ASME requirements for the pressures and temperatures given below. The ASME "U" symbol will be stamped on each tube bundle.

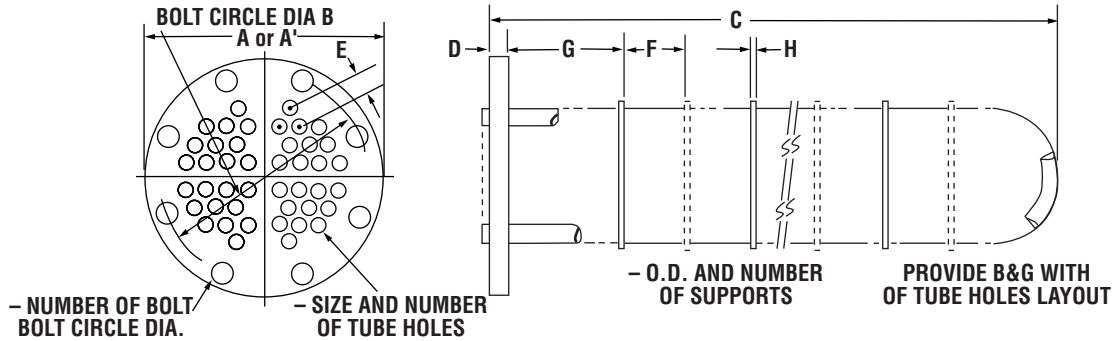

Manufacturer of existing unit _____

Model No. _____ Design Pressure & Temperature _____

A. Diameter of Tubesheet Full Tubesheet (A) _____ O.D. or
 Conventional Tubesheet (A) _____ O.D.

B. If full Tubesheet Design, Diameter of bolt hole circle (B) _____

Number of bolt holes _____ . Diameter of bolt holes _____ .
 Do bolt holes straddle centerline as indicated in above bundle drawing?

Yes/No. If No, describe _____

C. Diameter of Collar _____ O.D. and _____ I.D. (include thickness of collar lining, if any).

D. Length of Tube Bundle (C) _____ Actual? _____ Approx.? _____
 Length or diameter of tank _____ .

E. Thickness of Tubesheet (D) _____ . Material _____ .

F. Tube O.D _____ . Material _____ , Gauge _____ BWG
 or Wall Thickness _____ .

G. Number of Tubeholes in Tubesheet _____ . Tube Pitch (E) _____ .
 Tube Layout Triangular/Square. (Triangular indicated in above bundle drawing).

H. Tube Support Spacing (F) _____ . Distance to first tube support (G) _____

Tube Support material _____ . Diameter _____ Thickness (H) _____

Total number of tube supports _____ .

Note: Bell & Gossett will attempt to duplicate the dimensions above in the manufacturing of the tank heater replacement tube bundle. Since the standards, tolerances, and material thicknesses of Bell & Gossett may be different in comparison to other manufacturers, variations to the above dimensional data may occur.

DIMENSIONS (in inches)

NOTE:
TCW & TCS
 Indicates 3/4" OD Copper Tubes

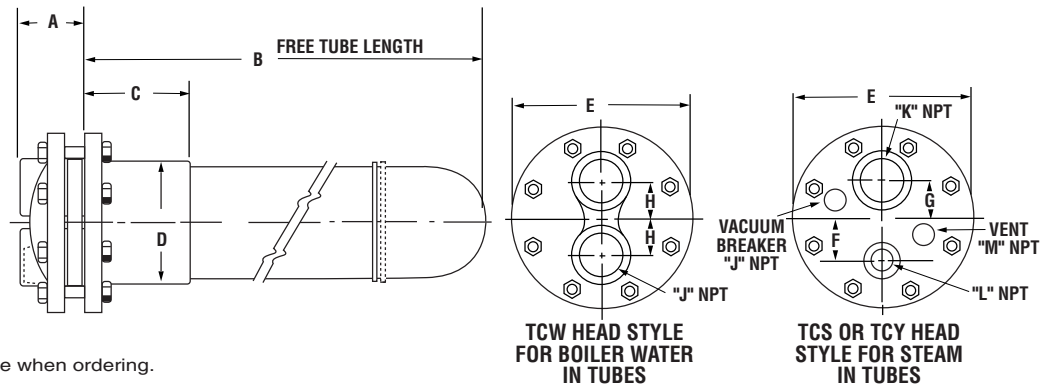

Please indicate head and tube style when ordering.

HEATING SURFACE SQ. FT.		A	B	C	D	E	F	G	H	J	K	L	M	N	
HEATER NO.	TCW TCS	TCW TCS	TCW TCS	TCW TCS											
TCW-TCS-412	2.1	2 1/8	2 1/8	11 1/4	6 1/8	4 1/2	7 1/4	1 11/16	1 5/16	1 5/16	1 1/2	1 1/4	3/4	1/2	1/4
TCW-TCS-418	3.3	2 1/8	2 1/8	17 1/4	6 1/8	4 1/2	7 1/4	1 11/16	1 5/16	1 5/16	1 1/2	1 1/4	3/4	1/2	1/4
TCW-TCS-424	4.5	2 1/8	2 1/8	23 1/4	6 1/8	4 1/2	7 1/4	1 11/16	1 5/16	1 5/16	1 1/2	1 1/4	3/4	1/2	1/4
TCW-TCS-430	5.6	2 1/8	2 1/8	29 1/4	6 1/8	4 1/2	7 1/4	1 11/16	1 5/16	1 5/16	1 1/2	1 1/4	3/4	1/2	1/4
TCW-TCS-436	6.8	2 1/8	2 1/8	35 1/4	6 1/8	4 1/2	7 1/4	1 11/16	1 5/16	1 5/16	1 1/2	1 1/4	3/4	1/2	1/4
TCW-TCS-442	8.0	2 1/8	2 1/8	41 1/4	6 1/8	4 1/2	7 1/4	1 11/16	1 5/16	1 5/16	1 1/2	1 1/4	3/4	1/2	1/4
TCW-TCS-448	9.2	2 1/8	2 1/8	47 1/4	6 1/8	4 1/2	7 1/4	1 11/16	1 5/16	1 5/16	1 1/2	1 1/4	3/4	1/2	1/4
TCW-TCS-454	10.4	2 1/8	2 1/8	53 1/4	6 1/8	4 1/2	7 1/4	1 11/16	1 5/16	1 5/16	1 1/2	1 1/4	3/4	1/2	1/4
TCW-TCS-460	11.5	2 1/8	2 1/8	59 1/4	6 1/8	4 1/2	7 1/4	1 11/16	1 5/16	1 5/16	1 1/2	1 1/4	3/4	1/2	1/4
TCW-TCS-466	12.7	2 1/8	2 1/8	65 1/4	6 1/8	4 1/2	7 1/4	1 11/16	1 5/16	1 5/16	1 1/2	1 1/4	3/4	1/2	1/4
TCW-TCS-472	13.9	2 1/8	2 1/8	71 1/4	6 1/8	4 1/2	7 1/4	1 11/16	1 5/16	1 5/16	1 1/2	1 1/4	3/4	1/2	1/4
TCW-TCS-484	16.3	2 1/8	2 1/8	83 1/4	6 1/8	4 1/2	7 1/4	1 11/16	1 5/16	1 5/16	1 1/2	1 1/4	3/4	1/2	1/4
TCW-TCS-496	18.6	2 1/8	2 1/8	95 1/4	6 1/8	4 1/2	7 1/4	1 11/16	1 5/16	1 5/16	1 1/2	1 1/4	3/4	1/2	1/4
TCW-TCS-612	3.3	2 3/4	2 1/2	9 7/8	6 1/8	6 5/8	10 1/2	2 9/16	1 7/8	1 7/8	2	2	1	1/2	1/2
TCW-TCS-618	5.6	2 3/4	2 1/2	15 7/8	6 1/8	6 5/8	10 1/2	2 9/16	1 7/8	1 7/8	2	2	1	1/2	1/2
TCW-TCS-624	8.0	2 3/4	2 1/2	21 7/8	6 1/8	6 5/8	10 1/2	2 9/16	1 7/8	1 7/8	2	2	1	1/2	1/2
TCW-TCS-630	10.3	2 3/4	2 1/2	27 7/8	6 1/8	6 5/8	10 1/2	2 9/16	1 7/8	1 7/8	2	2	1	1/2	1/2
TCW-TCS-636	12.7	2 3/4	2 1/2	33 7/8	6 1/8	6 5/8	10 1/2	2 9/16	1 7/8	1 7/8	2	2	1	1/2	1/2
TCW-TCS-642	15.0	2 3/4	2 1/2	39 7/8	6 1/8	6 5/8	10 1/2	2 9/16	1 7/8	1 7/8	2	2	1	1/2	1/2
TCW-TCS-648	17.4	2 3/4	2 1/2	45 7/8	6 1/8	6 5/8	10 1/2	2 9/16	1 7/8	1 7/8	2	2	1	1/2	1/2
TCW-TCS-654	19.7	2 3/4	2 1/2	51 7/8	6 1/8	6 5/8	10 1/2	2 9/16	1 7/8	1 7/8	2	2	1	1/2	1/2
TCW-TCS-660	22.1	2 3/4	2 1/2	57 7/8	6 1/8	6 5/8	10 1/2	2 9/16	1 7/8	1 7/8	2	2	1	1/2	1/2
TCW-TCS-666	24.1	2 3/4	2 1/2	63 7/8	6 1/8	6 5/8	10 1/2	2 9/16	1 7/8	1 7/8	2	2	1	1/2	1/2
TCW-TCS-672	26.8	2 3/4	2 1/2	69 7/8	6 1/8	6 5/8	10 1/2	2 9/16	1 7/8	1 7/8	2	2	1	1/2	1/2
TCW-TCS-684	31.5	2 3/4	2 1/2	81 7/8	6 1/8	6 5/8	10 1/2	2 9/16	1 7/8	1 7/8	2	2	1	1/2	1/2
TCW-TCS-696	36.2	2 3/4	2 1/2	93 7/8	6 1/8	6 5/8	10 1/2	2 9/16	1 7/8	1 7/8	2	2	1	1/2	1/2
TCW-TCS-818	11.0	3 3/8	3 3/8	16 1/4	8	8 5/8	12 1/2	3 3/8	2 1/4	2 1/2	3	3	1 1/4	1/2	1/2
TCW-TCS-824	15.0	3 3/8	3 3/8	22 1/4	8	8 5/8	12 1/2	3 3/8	2 1/4	2 1/2	3	3	1 1/4	1/2	1/2
TCW-TCS-830	19.0	3 3/8	3 3/8	28 1/4	8	8 5/8	12 1/2	3 3/8	2 1/4	2 1/2	3	3	1 1/4	1/2	1/2
TCW-TCS-836	23.0	3 3/8	3 3/8	34 1/4	8	8 5/8	12 1/2	3 3/8	2 1/4	2 1/2	3	3	1 1/4	1/2	1/2
TCW-TCS-842	27.0	3 3/8	3 3/8	40 1/4	8	8 5/8	12 1/2	3 3/8	2 1/4	2 1/2	3	3	1 1/4	1/2	1/2
TCW-TCS-848	32.0	3 3/8	3 3/8	46 1/4	8	8 5/8	12 1/2	3 3/8	2 1/4	2 1/2	3	3	1 1/4	1/2	1/2
TCW-TCS-854	36.5	3 3/8	3 3/8	52 1/4	8	8 5/8	12 1/2	3 3/8	2 1/4	2 1/2	3	3	1 1/4	1/2	1/2
TCW-TCS-860	41.0	3 3/8	3 3/8	58 1/4	8	8 5/8	12 1/2	3 3/8	2 1/4	2 1/2	3	3	1 1/4	1/2	1/2
TCW-TCS-866	45.0	3 3/8	3 3/8	64 1/4	8	8 5/8	12 1/2	3 3/8	2 1/4	2 1/2	3	3	1 1/4	1/2	1/2
TCW-TCS-872	49.0	3 3/8	3 3/8	70 1/4	8	8 5/8	12 1/2	3 3/8	2 1/4	2 1/2	3	3	1 1/4	1/2	1/2
TCW-TCS-884	58.0	3 3/8	3 3/8	82 1/4	8	8 5/8	12 1/2	3 3/8	2 1/4	2 1/2	3	3	1 1/4	1/2	1/2
TCW-TCS-896	67.0	3 3/8	3 3/8	94 1/4	8	8 5/8	12 1/2	3 3/8	2 1/4	2 1/2	3	3	1 1/4	1/2	1/2

Dimensions are subject to change. If exact dimensions are needed for layout, write for certified prints.

DIMENSIONS (in inches) – continued

NOTE:
TCW & TCS
 Indicates 3/4" OD Copper Tubes

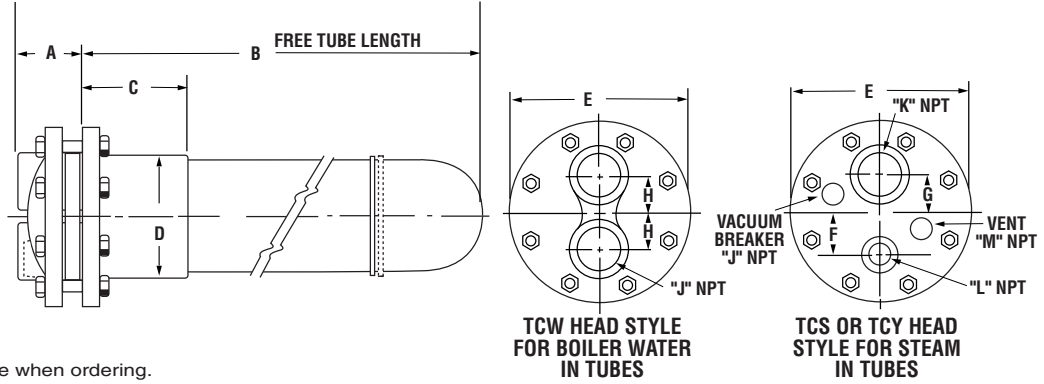

Please indicate head and tube style when ordering.

HEATING SURFACE SQ. FT.		A		B	C	D	E	F	G	H	J	K	L	M	N
HEATER NO.	TCW TCS	TCW	TCS	TCW TCS											
TCW-TCS-1024	27	3 ³ / ₈	3 ³ / ₈	23 ³ / ₈	8 ¹ / ₄	10 ³ / ₄	14 ⁵ / ₈	4 ¹ / ₁₆	2 ¹³ / ₁₆	2 ¹⁵ / ₁₆	4	4	2	3 ³ / ₄	3 ³ / ₄
TCW-TCS-1030	34.5	3 ³ / ₈	3 ³ / ₈	29 ³ / ₈	8 ¹ / ₄	10 ³ / ₄	14 ⁵ / ₈	4 ¹ / ₁₆	2 ¹³ / ₁₆	2 ¹⁵ / ₁₆	4	4	2	3 ³ / ₄	3 ³ / ₄
TCW-TCS-1036	42	3 ³ / ₈	3 ³ / ₈	35 ³ / ₈	8 ¹ / ₄	10 ³ / ₄	14 ⁵ / ₈	4 ¹ / ₁₆	2 ¹³ / ₁₆	2 ¹⁵ / ₁₆	4	4	2	3 ³ / ₄	3 ³ / ₄
TCW-TCS-1042	49.5	3 ³ / ₈	3 ³ / ₈	41 ³ / ₈	8 ¹ / ₄	10 ³ / ₄	14 ⁵ / ₈	4 ¹ / ₁₆	2 ¹³ / ₁₆	2 ¹⁵ / ₁₆	4	4	2	3 ³ / ₄	3 ³ / ₄
TCW-TCS-1048	56	3 ³ / ₈	3 ³ / ₈	47 ³ / ₈	8 ¹ / ₄	10 ³ / ₄	14 ⁵ / ₈	4 ¹ / ₁₆	2 ¹³ / ₁₆	2 ¹⁵ / ₁₆	4	4	2	3 ³ / ₄	3 ³ / ₄
TCW-TCS-1054	63.5	3 ³ / ₈	3 ³ / ₈	53 ³ / ₈	8 ¹ / ₄	10 ³ / ₄	14 ⁵ / ₈	4 ¹ / ₁₆	2 ¹³ / ₁₆	2 ¹⁵ / ₁₆	4	4	2	3 ³ / ₄	3 ³ / ₄
TCW-TCS-1060	71	3 ³ / ₈	3 ³ / ₈	59 ³ / ₈	8 ¹ / ₄	10 ³ / ₄	14 ⁵ / ₈	4 ¹ / ₁₆	2 ¹³ / ₁₆	2 ¹⁵ / ₁₆	4	4	2	3 ³ / ₄	3 ³ / ₄
TCW-TCS-1066	78.5	3 ³ / ₈	3 ³ / ₈	65 ³ / ₈	8 ¹ / ₄	10 ³ / ₄	14 ⁵ / ₈	4 ¹ / ₁₆	2 ¹³ / ₁₆	2 ¹⁵ / ₁₆	4	4	2	3 ³ / ₄	3 ³ / ₄
TCW-TCS-1072	86	3 ³ / ₈	3 ³ / ₈	71 ³ / ₈	8 ¹ / ₄	10 ³ / ₄	14 ⁵ / ₈	4 ¹ / ₁₆	2 ¹³ / ₁₆	2 ¹⁵ / ₁₆	4	4	2	3 ³ / ₄	3 ³ / ₄
TCW-TCS-1084	101	3 ³ / ₈	3 ³ / ₈	83 ³ / ₈	8 ¹ / ₄	10 ³ / ₄	14 ⁵ / ₈	4 ¹ / ₁₆	2 ¹³ / ₁₆	2 ¹⁵ / ₁₆	4	4	2	3 ³ / ₄	3 ³ / ₄
TCW-TCS-1096	116	3 ³ / ₈	3 ³ / ₈	95 ³ / ₈	8 ¹ / ₄	10 ³ / ₄	14 ⁵ / ₈	4 ¹ / ₁₆	2 ¹³ / ₁₆	2 ¹⁵ / ₁₆	4	4	2	3 ³ / ₄	3 ³ / ₄
TCW-TCS-10108	131	3 ³ / ₈	3 ³ / ₈	107 ³ / ₈	8 ¹ / ₄	10 ³ / ₄	14 ⁵ / ₈	4 ¹ / ₁₆	2 ¹³ / ₁₆	2 ¹⁵ / ₁₆	4	4	2	3 ³ / ₄	3 ³ / ₄
TCW-TCS-1236	61	3 ³ / ₈	5 ¹ / ₈	36 ¹ / ₄	10 ¹ / ₄	12 ³ / ₄	16 ⁵ / ₈	5 ¹ / ₁₆	3 ¹¹ / ₁₆	3 ¹¹ / ₁₆	4	4	2	3 ³ / ₄	3 ³ / ₄
TCW-TCS-1242	72	3 ³ / ₈	5 ¹ / ₈	42 ¹ / ₄	10 ¹ / ₄	12 ³ / ₄	16 ⁵ / ₈	5 ¹ / ₁₆	3 ¹¹ / ₁₆	3 ¹¹ / ₁₆	4	4	2	3 ³ / ₄	3 ³ / ₄
TCW-TCS-1248	83	3 ³ / ₈	5 ¹ / ₈	48 ¹ / ₄	10 ¹ / ₄	12 ³ / ₄	16 ⁵ / ₈	5 ¹ / ₁₆	3 ¹¹ / ₁₆	3 ¹¹ / ₁₆	4	4	2	3 ³ / ₄	3 ³ / ₄
TCW-TCS-1254	94	3 ³ / ₈	5 ¹ / ₈	54 ¹ / ₄	10 ¹ / ₄	12 ³ / ₄	16 ⁵ / ₈	5 ¹ / ₁₆	3 ¹¹ / ₁₆	3 ¹¹ / ₁₆	4	4	2	3 ³ / ₄	3 ³ / ₄
TCW-TCS-1260	104	3 ³ / ₈	5 ¹ / ₈	60 ¹ / ₄	10 ¹ / ₄	12 ³ / ₄	16 ⁵ / ₈	5 ¹ / ₁₆	3 ¹¹ / ₁₆	3 ¹¹ / ₁₆	4	4	2	3 ³ / ₄	3 ³ / ₄
TCW-TCS-1266	115	3 ³ / ₈	5 ¹ / ₈	66 ¹ / ₄	10 ¹ / ₄	12 ³ / ₄	16 ⁵ / ₈	5 ¹ / ₁₆	3 ¹¹ / ₁₆	3 ¹¹ / ₁₆	4	4	2	3 ³ / ₄	3 ³ / ₄
TCW-TCS-1272	126	3 ³ / ₈	5 ¹ / ₈	72 ¹ / ₄	10 ¹ / ₄	12 ³ / ₄	16 ⁵ / ₈	5 ¹ / ₁₆	3 ¹¹ / ₁₆	3 ¹¹ / ₁₆	4	4	2	3 ³ / ₄	3 ³ / ₄
TCW-TCS-1278	137	3 ³ / ₈	5 ¹ / ₈	78 ¹ / ₄	10 ¹ / ₄	12 ³ / ₄	16 ⁵ / ₈	5 ¹ / ₁₆	3 ¹¹ / ₁₆	3 ¹¹ / ₁₆	4	4	2	3 ³ / ₄	3 ³ / ₄
TCW-TCS-1284	147	3 ³ / ₈	5 ¹ / ₈	84 ¹ / ₄	10 ¹ / ₄	12 ³ / ₄	16 ⁵ / ₈	5 ¹ / ₁₆	3 ¹¹ / ₁₆	3 ¹¹ / ₁₆	4	4	2	3 ³ / ₄	3 ³ / ₄
TCW-TCS-1296	169	3 ³ / ₈	5 ¹ / ₈	96 ¹ / ₄	10 ¹ / ₄	12 ³ / ₄	16 ⁵ / ₈	5 ¹ / ₁₆	3 ¹¹ / ₁₆	3 ¹¹ / ₁₆	4	4	2	3 ³ / ₄	3 ³ / ₄
TCW-TCS-12108	191	3 ³ / ₈	5 ¹ / ₈	108 ¹ / ₄	10 ¹ / ₄	12 ³ / ₄	16 ⁵ / ₈	5 ¹ / ₁₆	3 ¹¹ / ₁₆	3 ¹¹ / ₁₆	4	4	2	3 ³ / ₄	3 ³ / ₄
TCW-TCS-12120	212	3 ³ / ₈	5 ¹ / ₈	120 ¹ / ₄	10 ¹ / ₄	12 ³ / ₄	16 ⁵ / ₈	5 ¹ / ₁₆	3 ¹¹ / ₁₆	3 ¹¹ / ₁₆	4	4	2	3 ³ / ₄	3 ³ / ₄
TCW-TCS-1436	86	6 ³ / ₈	6 ³ / ₈	37 ¹ / ₂	10 ¹ / ₄	14	17 ⁷ / ₈	5 ¹ / ₈	3 ⁵ / ₈	4	6	6	3	3 ³ / ₄	3 ³ / ₄
TCW-TCS-1442	102	6 ³ / ₈	6 ³ / ₈	43 ¹ / ₂	10 ¹ / ₄	14	17 ⁷ / ₈	5 ¹ / ₈	3 ⁵ / ₈	4	6	6	3	3 ³ / ₄	3 ³ / ₄
TCW-TCS-1448	116	6 ³ / ₈	6 ³ / ₈	49 ¹ / ₂	10 ¹ / ₄	14	17 ⁷ / ₈	5 ¹ / ₈	3 ⁵ / ₈	4	6	6	3	3 ³ / ₄	3 ³ / ₄
TCW-TCS-1454	131	6 ³ / ₈	6 ³ / ₈	55 ¹ / ₂	10 ¹ / ₄	14	17 ⁷ / ₈	5 ¹ / ₈	3 ⁵ / ₈	4	6	6	3	3 ³ / ₄	3 ³ / ₄
TCW-TCS-1460	146	6 ³ / ₈	6 ³ / ₈	61 ¹ / ₂	10 ¹ / ₄	14	17 ⁷ / ₈	5 ¹ / ₈	3 ⁵ / ₈	4	6	6	3	3 ³ / ₄	3 ³ / ₄
TCW-TCS-1466	161	6 ³ / ₈	6 ³ / ₈	67 ¹ / ₂	10 ¹ / ₄	14	17 ⁷ / ₈	5 ¹ / ₈	3 ⁵ / ₈	4	6	6	3	3 ³ / ₄	3 ³ / ₄
TCW-TCS-1472	175	6 ³ / ₈	6 ³ / ₈	73 ¹ / ₂	10 ¹ / ₄	14	17 ⁷ / ₈	5 ¹ / ₈	3 ⁵ / ₈	4	6	6	3	3 ³ / ₄	3 ³ / ₄
TCW-TCS-1478	190	6 ³ / ₈	6 ³ / ₈	79 ¹ / ₂	10 ¹ / ₄	14	17 ⁷ / ₈	5 ¹ / ₈	3 ⁵ / ₈	4	6	6	3	3 ³ / ₄	3 ³ / ₄
TCW-TCS-1484	204	6 ³ / ₈	6 ³ / ₈	85 ¹ / ₂	10 ¹ / ₄	14	17 ⁷ / ₈	5 ¹ / ₈	3 ⁵ / ₈	4	6	6	3	3 ³ / ₄	3 ³ / ₄
TCW-TCS-1496	234	6 ³ / ₈	6 ³ / ₈	97 ¹ / ₂	10 ¹ / ₄	14	17 ⁷ / ₈	5 ¹ / ₈	3 ⁵ / ₈	4	6	6	3	3 ³ / ₄	3 ³ / ₄
TCW-TCS-14108	263	6 ³ / ₈	6 ³ / ₈	109 ¹ / ₂	10 ¹ / ₄	14	17 ⁷ / ₈	5 ¹ / ₈	3 ⁵ / ₈	4	6	6	3	3 ³ / ₄	3 ³ / ₄
TCW-TCS-14120	292	6 ³ / ₈	6 ³ / ₈	121 ¹ / ₂	10 ¹ / ₄	14	17 ⁷ / ₈	5 ¹ / ₈	3 ⁵ / ₈	4	6	6	3	3 ³ / ₄	3 ³ / ₄

Dimensions are subject to change. If exact dimensions are needed for layout, write for certified prints.

HEAD AND PRESSURE EQUIVALENTS

FEET HEAD OF WATER AND EQUIVALENT PRESSURES PRESSURES AND EQUIVALENT FEET HEAD OF WATER

Feet Head	Pounds per Sq. In.	Feet Head	Pounds per Sq. In.	Feet Head	Pounds per Sq. In.	Feet Head	Pounds per Sq. In.	Lbs. per Sq. In.	Feet Head	Lbs. per Sq. In.	Feet Head	Lbs. per Sq. In.	Feet Head	Lbs. per Sq. In.	Feet Head
1	.43	30	12.99	140	60.63	300	129.93	1	2.31	20	46.18	120	277.07	225	519.51
2	.87	40	17.32	150	64.96	325	140.75	2	4.62	25	57.72	125	288.62	250	577.24
3	1.30	50	21.65	160	69.29	350	151.58	3	6.93	30	69.27	130	300.16	275	643.03
4	1.73	60	25.99	170	73.63	400	173.24	4	9.24	40	92.36	140	323.25	300	692.69
5	2.17	70	30.32	180	77.96	500	216.55	5	11.54	50	115.45	150	346.34	325	750.41
6	2.60	80	34.65	190	82.29	600	259.85	6	13.85	60	138.54	160	369.43	350	808.13
7	3.03	90	38.98	200	86.62	700	303.16	7	16.16	70	161.63	170	392.52	375	865.89
8	3.46	100	43.31	225	97.45	800	346.47	8	18.47	80	184.72	180	415.61	400	922.58
9	3.90	110	47.64	250	108.27	900	389.78	9	20.78	90	207.81	190	438.90	500	1154.48
10	4.33	120	51.97	275	119.10	1000	433.09	10	23.09	100	230.90	200	461.78	1000	2309.00
20	8.66	130	56.30	15	34.63	110	253.98

CONVERSION FACTORS

TO CONVERT FROM	TO	MULTIPLY BY	TO CONVERT FROM	TO	MULTIPLY BY
Pressure			Temperature		
Atmospheres	ft. of water	33.9	Centigrade degrees.....	Fahrenheit degrees.....	1.8 and add 32°
Atmospheres	mm. of mercury	760.0	Fahrenheit degrees.....	Centigrade degrees.....	Subtract 32° and multiply by 0.5555
Atmospheres	pounds/sq. in.....	14.696	Measure		
Feet of water (40°F).....	pounds/sq. in.....	0.4335	Centimeters.....	inches.....	0.3937
Inches of mercury (32°F)....	feet of water (40°F).....	1.133	Feet.....	meters.....	0.3048
Inches of mercury (32°F)....	pounds/sq. in.....	0.49116	Inches.....	centimeters.....	2.54
Inches of water (40°F).....	pounds/sq. in.....	0.03614	Kilometers.....	miles.....	0.6214
mm. of mercury (32°F).....	pounds/sq. in.....	0.01934	Meters.....	feet.....	3.2808
Pounds/sq. in.....	feet of water (40°F).....	2.3066	Microns.....	millimeters.....	0.001
Pounds/sq. in.....	inches of mercury (32°F)....	2.036	Sq. meters.....	sq. feet.....	10.764
Volume			Weight		
Barrels (oil).....	gallons.....	42.0	Cubic ft. of water (60°F)	pounds.....	62.37
Barrels (breweries).....	gallons.....	31.0	Gallons.....	pounds of water (60°F).....	8.34
Cubic cm.....	cubic inches.....	0.061023	Grains.....	pounds.....	1/7000
Cubic ft.....	cubic inches.....	1728.0	Grains/gal.....	parts per million.....	17.12
Cubic ft.....	cubic meters.....	0.02832	Grams.....	grains.....	15.43
Cubic ft.....	gallons.....	7.481	Kilograms.....	pounds.....	2.2046
Cubic meters.....	gallons.....	264.17	Pounds.....	grams.....	453.59
Gallons.....	cubic ft.....	0.1337	Tons (long).....	tons (short).....	1.12
Gallons.....	cubic inches.....	231.0	Volumetric Rate		
Gallons.....	gallons (British).....	0.83268	Cubic ft./sec.....	gallons/min.....	448.83
Gallons.....	liters.....	3.7853	Gallons/min.....	cu. ft./sec.....	0.00223
Liters.....	gallons.....	0.2642	Power		
Liters.....	quarts.....	1.0567	Horsepower.....	ft. lbs./sec.....	550.0
Heat			Horsepower.....	K.W.....	0.745
Boiler horsepower (BHP) ...	BTU/hr.....	33479.0	Viscosity		
BTU.....	calories (gram).....	252.0	Centipoises.....	lbs.sec./ft.....	0.000672
BTU.....	calories (kg).....	0.252	Poises.....	centipoises.....	0.01
Calories (gram)/gram°C....	BTU/pound/°F.....	1.0	Velocity		
Calories (gram) per gram...	BTU/pound.....	1.8	Ft./sec.....	meters/sec.....	0.3048
Horsepower.....	BTU/hr.....	2545.0	Meters/sec.....	ft./sec.....	3.2808
K.W. hours.....	BTU.....	3413.0			

Xylem |'zīləm |

- 1) The tissue in plants that brings water upward from the roots;
- 2) a leading global water technology company.

We're 12,700 people unified in a common purpose: creating innovative solutions to meet our world's water needs. Developing new technologies that will improve the way water is used, conserved, and re-used in the future is central to our work. We move, treat, analyze, and return water to the environment, and we help people use water efficiently, in their homes, buildings, factories and farms. In more than 150 countries, we have strong, long-standing relationships with customers who know us for our powerful combination of leading product brands and applications expertise, backed by a legacy of innovation.

For more information on how Xylem can help you, go to www.xylem.com



Xylem Inc.
8200 N. Austin Avenue
Morton Grove, Illinois 60053
Phone: (847) 966-3700
Fax: (847) 965-8379
www.bellgossett.com

Bell & Gossett is a trademark of Xylem Inc. or one of its subsidiaries.
© 2013 Xylem Inc. C-115E March 2009